

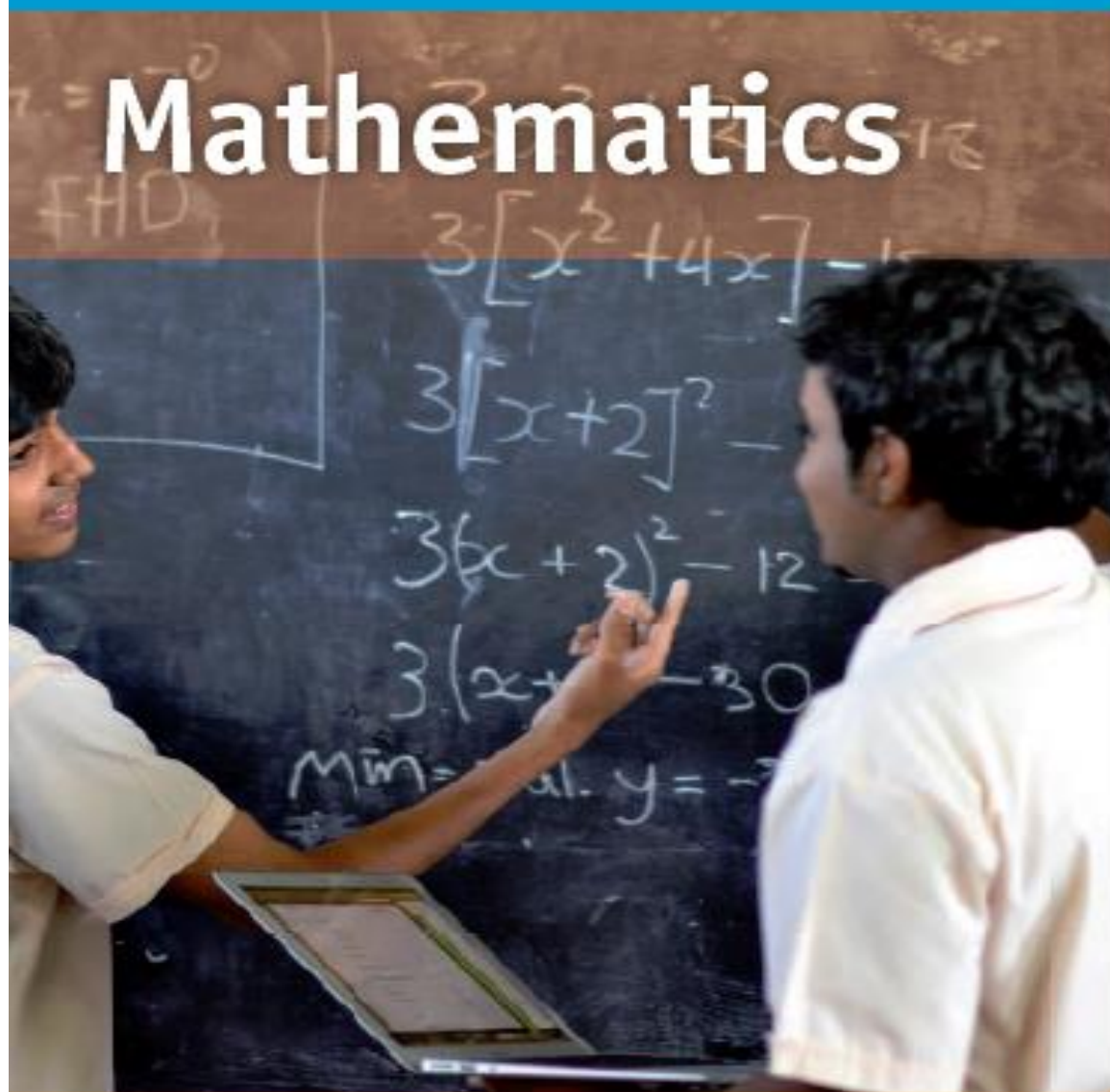

CARIBBEAN EXAMINATIONS COUNCIL

Mathematics



CSEC[®] PAST PAPERS

Paper 02 May 2002

Paper 02 May 2002

Paper 02 May 2003

Paper 02 May 2003

Paper 02 May 2004

Paper 02 May 2004

Multiple Choice 2004

Paper 02 January 2005

Paper 02 May 2005

Paper 02 May 2005

Paper 02 January 2006

Paper 02 May 2006

Paper 02 May 2006

Paper 02 January 2008

Paper 02 May 2008

Paper 02 May 2008

Multiple Choice 2008

Multiple Choice 2008

Paper 02 January 2009

Paper 02 May/June 2009

Paper 02 May/June 2009

Paper 02 January 2010

Paper 02 May/June 2010

Paper 02 January 2011

Paper 02 May/June 2011

Paper 02 January 2012

Paper 02 May/June 2012

Paper 02 January 2013

Paper 02 May/June 2013

Paper 02 January 2014

Paper 02 May/June 2014

Paper 02 January 2015

Paper 02 May/June 2015

Paper 02 January 2016

Paper 02 May/June 2016

FORM TP 22119

TEST CODE **000592**

MAY/JUNE 2002

CARIBBEAN EXAMINATIONS COUNCIL

**SECONDARY EDUCATION CERTIFICATE
EXAMINATION**

MATHEMATICS

Paper 02 - General Proficiency

2 hours 40 minutes

30 MAY 2002 (a.m.)

INSTRUCTIONS TO CANDIDATES

1. Answer ALL questions in Section I, and any TWO in Section II.
2. Begin the answer for each question on a new page.
3. Full marks may not be awarded unless full working or explanation is shown with the answer.
4. Mathematical tables, formulae and graph paper are provided.
5. Mathematical instruments and silent electronic calculators may be used for this paper.
6. You are advised to use the first 10 minutes of the examination time to read through this paper. Writing may begin during this 10-minute period.

DO NOT TURN THIS PAGE UNTIL YOU ARE TOLD TO DO SO

Copyright © 2001 Caribbean Examinations Council.
All rights reserved.

SECTION I

Answer ALL the questions in this section.

ALL working must be clearly shown.

1. (a) Calculate the exact value of

$$\frac{3\frac{1}{4} - 2\frac{1}{3}}{1\frac{5}{6}}$$

(3 marks)

- (b) Write the value of

$$(11.2)^2 - (0.375 \div 3)$$

- (i) exactly
 (ii) to two significant figures
 (iii) in standard form.

(5 marks)

- (c) A metal is made from copper, zinc and lead in the ratio 13 : 6 : 1. The mass of the zinc is 90 kg. Calculate the mass of the metal. (4 marks)

Total 12 marks

2. (a) Simplify

(i) $3m - 2(m + 1)$

(ii) $\frac{3}{y} - \frac{2}{y-2}$

(5 marks)

- (b) Solve the equation

$$2(x - 1) = \frac{5}{2}$$

(3 marks)

- (c) Calculate the range of values of
- v
- when
- $5 - v \leq 2v - 1$
- .

(3 marks)

Total 11 marks

GO ON TO THE NEXT PAGE

3. (a)

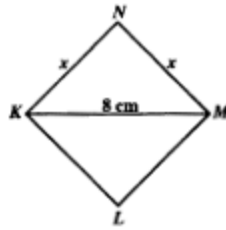

The diagram above, not drawn to scale, shows a square $KLMN$, where $KM = 8$ cm and $KN = MN = x$ cm.

Show that $x^2 = 32$.

(2 marks)

(b) (i) Using ruler and compasses only

- a) draw the diagonal $KM = 8$ cm
- b) construct the perpendicular bisector of KM .

(ii) Hence, draw the square $KLMN$.

(5 marks)

(c)

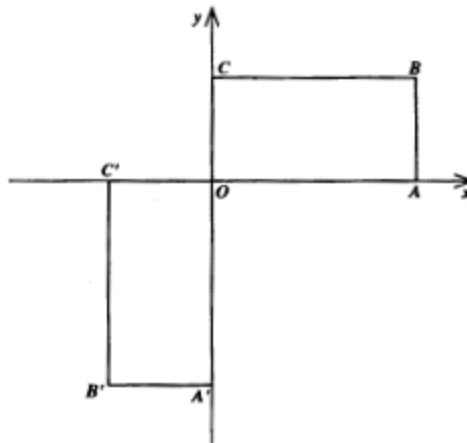

In the diagram above, $OC = OC'$, $BC = B'C'$ and all angles are right angles. $OABC$ can be mapped onto $OA'B'C'$ by a transformation, J , followed by another transformation, K .

Describe fully the transformations

- (i) J
- (ii) K .

(3 marks)

Total 10 marks

GO ON TO THE NEXT PAGE

4. (a)

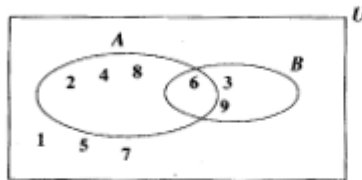

In the Venn diagram above,

$U = \{\text{whole numbers less than } 10\}$, and
 A and B are subsets of U .

- Describe A and B in words.
- List the members of $A \cap B$ and describe the set, in words, in relation to A and B .
- Determine $n(A \cup B)^c$. (5 marks)

(b)

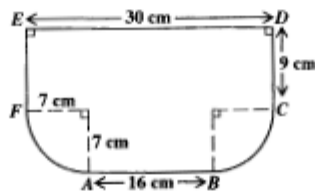

The diagram above, **not drawn to scale**, shows $ABCDEF$, a vertical cross-section of a container with ED being the top edge. DC and EF are vertical edges. BC and AF are arcs of a circle of radius 7 cm and $AB \parallel ED$.

$ED = 30$ cm; $AB = 16$ cm; $EF = DC = 9$ cm.

- Taking $\pi = \frac{22}{7}$, show that the area of $ABCDEF$ is 459 cm².
- Water is poured into the container until the water level is 4 cm from the top. If the container is 40 cm long and has uniform cross-section, calculate, to the nearest litre, the volume of water in the container. (7 marks)

Total 12 marks

5. (a) Given that $\vec{PR} = \begin{pmatrix} b \\ -2b \end{pmatrix}$
 and $\vec{PS} = \begin{pmatrix} 3b \\ b+1 \end{pmatrix}$,
- (i) express EACH of the vectors \vec{RP} and \vec{RS} in the simplest form
 (ii) determine the values of b if $|\vec{PR}| = \sqrt{20}$ units. **(6 marks)**
- (b) A man travelled a total distance of 8 km in 54 minutes by running and walking. He ran x km at 10 km h^{-1} and walked the remaining distance at 5 km h^{-1} .
- (i) Write an expression in x for the time, in hours, that
- a) he ran
 b) he walked. **(3 marks)**
- (ii) a) Form an equation in x for the total time, in hours, spent travelling.
 b) Calculate the value of x .
 c) Hence, calculate the distance the man walked. **(3 marks)**

Total 12 marks

6. The functions, f and g , are defined by

$$f(x) = \frac{x}{3} + 1 \text{ and}$$

$$g(x) = 2x - 1.$$

- (a) Calculate $g(-3)$. **(1 mark)**
- (b) Find, in its simplest form,
- (i) $f^{-1}(x)$
 (ii) $g^{-1}(x)$
 (iii) $fg(x)$
 (iv) $(fg)^{-1}(x)$. **(7 marks)**
- (c) Show that $(fg)^{-1}(x) = g^{-1}f^{-1}(x)$. **(3 marks)**

Total 11 marks

GO ON TO THE NEXT PAGE

7. (a)

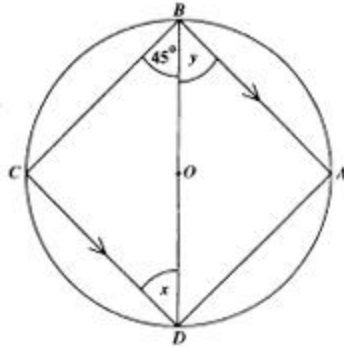

The diagram above, **not drawn to scale**, shows a circle, centre O . BA is parallel to CD and $\hat{C}BD = 45^\circ$.

- (i) Calculate, giving reasons, the values of x and y .
- (ii) Show that $ABCD$ is a square, giving the reasons for your answer.

(6 marks)

- (b) Points O , P and Q are in the same horizontal plane. P is 15 m away from O on a bearing of 040° from O . Q is on a bearing of 130° from O , and $PQ = 17$ m.

- (i) Sketch a diagram to show the positions of O , P and Q . Clearly indicate North on your diagram.
- (ii) Calculate the distance OQ .

(6 marks)**Total 12 marks**

8. A student estimated that he had 30 hours available each week for home study and for sports. The table below shows the percentage of time he spent on each activity.

Activities	%
Languages	30
Mathematics	20
Computer Studies	15
Sciences	15
Sports	x

- (a) Calculate the number of hours spent on sports. **(2 marks)**
- (b) Calculate the angles in a pie chart that would be used to represent the hours spent on
- Mathematics
 - Languages. **(2 marks)**
- (c) Draw a pie chart to represent the distribution of hours in the week, which the student spends on the activities indicated in the table above. **(3 marks)**
- (d) One hour in the 30 hours is chosen at random. Calculate the probability that the student is
- playing sports
 - studying Mathematics or Languages. **(3 marks)**

Total 10 marks

SECTION II

Answer TWO questions in this section.

RELATIONS, FUNCTIONS AND GRAPHS

9. (a) Given that $y = \frac{1}{2}x^2$, copy and complete the table below.

x	-2	-1	0	1	2	3
y		-0.5	0		4	13.5

(2 marks)

- (b) Using scales of 2 cm to represent 1 unit on the x -axis, and 1 cm to represent 1 unit on the y -axis, draw the graph of the function y for

$$-2 \leq x \leq 3.$$

(7 marks)

- (c) Using the graph
- solve the equation, $\frac{1}{2}x^3 = 4$
 - determine the values of x for which $\frac{1}{2}x^3 \leq 4$. (4 marks)
- (d) Using the same axes and scales
- draw the graph of $y = 2$
 - write down the equation in x whose root is given by the intersection of the graphs, $y = 2$ and $y = \frac{1}{2}x^3$. (2 marks)

Total 15 marks

10. (a)

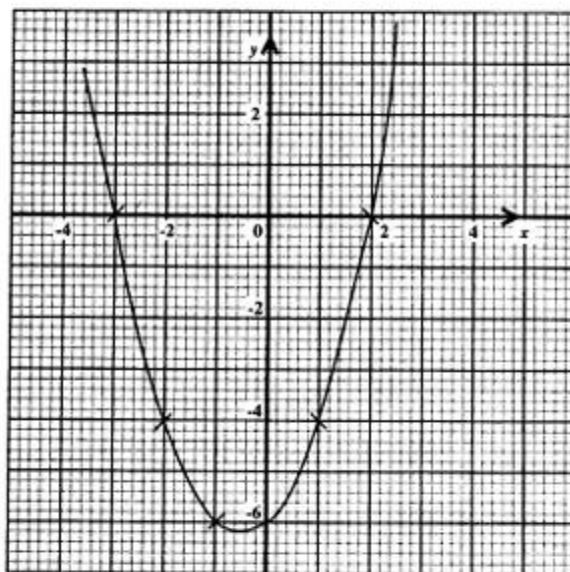
The diagram above shows the graph of the function $y = px^2 + qx + r$.

- Determine the values of p , q , and r .
- State TWO ways in which the graphs of the functions $y = px^2$ and $y = px^2 + qx + r$ are similar.
- State ONE way in which the graphs of the two functions is different. (8 marks)

(b)

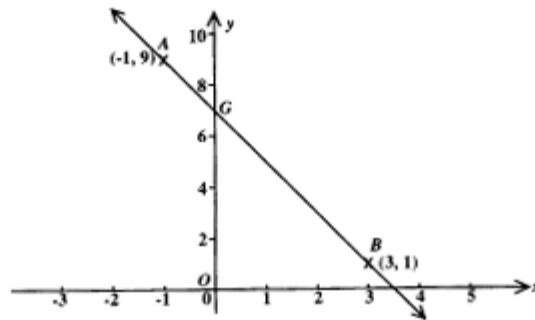

In the diagram above, **not drawn to scale**, AB is the straight line joining $A(-1, 9)$ and $B(3, 1)$.

- (i) Calculate the gradient of the line, AB .
- (ii) Determine the equation of the line, AB .
- (iii) Write the coordinates of G , the point of intersection of AB and the y -axis.
- (iv) Write the equation of the line through O , the origin, that is perpendicular to AB .
- (v) Write the equation of the line through O that is parallel to AB .

(7 marks)

Total 15 marks

GEOMETRY AND TRIGONOMETRY

11. (a) In $\triangle JKL$, the coordinates of the vertices are $J(0, 1)$, $K(5, -4)$ and $L(7, 2)$.

- (i) Draw $\triangle JKL$.
- (ii) Determine the coordinates of M , the midpoint of KL .
- (iii) Show by calculation, that $JK = JL$.

(7 marks)

(b)

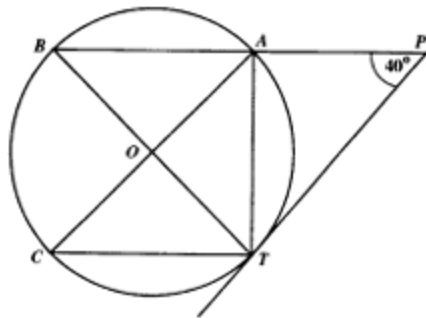

In the diagram above, **not drawn to scale**, $ABCT$ is a circle. AC and BT are diameters. TP , the tangent at T , meets BA produced at P , so that $\angle APT = 40^\circ$.

Calculate, **giving reasons for all statements**, the size of

- (i) $\angle BTP$
- (ii) $\angle BAT$
- (iii) $\angle ABT$
- (iv) $\angle ACT$.

(8 marks)

Total 15 marks

12. (a)

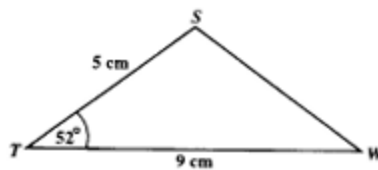

In the diagram above, **not drawn to scale**, $ST = 5$ cm, $TW = 9$ cm and $\angle STW = 52^\circ$.

Calculate

- (i) the length of SW
- (ii) the area of $\triangle STW$.

(7 marks)

(b)

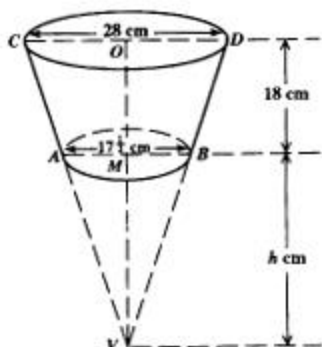

The diagram above, **not drawn to scale**, shows $ABCD$, a bucket of height 18 cm. The bucket is made by removing a cone VAB , of height h cm, from a larger cone VCD .

AMB , the diameter of the circular base of the bucket is $17\frac{1}{2}$ cm. COD , the diameter of the open top, is 28 cm.

- (i) Show, giving reasons, that $\frac{h}{18+h} = \frac{5}{8}$.
- (ii) Determine the value of h .

(8 marks)

Total 15 marks**VECTORS AND MATRICES**

13. (a) Given that $M = \begin{pmatrix} n+1 & 2 \\ 2n & n \end{pmatrix}$

- (i) write down an expression for the determinant of M
- (ii) find M^{-1} .

(4 marks)

(b) The coordinates of the vertices of ΔPQS are $P(1, 5)$, $Q(4, -1)$ and $S(6, 0)$.

- (i) Write down the position vectors, \vec{PQ} and \vec{PS} .
- (ii) Determine the position vectors, \vec{OG} and \vec{OH} , given that G and H are the midpoints of PQ and PS respectively.
- (iii) Determine the vectors \vec{GH} and \vec{QS} .
- (iv) Hence, state TWO geometrical relationships between GH and QS . (11 marks)

Total 15 marks

GO ON TO THE NEXT PAGE

14. An answer sheet is provided for Parts (d) and (e).

- (a) Write down the matrix
- (i) M_y that represents reflection in the y-axis
 - (ii) R_I that represents a rotation of 180° about the origin. (2 marks)
- (b) Determine the single matrix, U , that represents a transformation, M_y , followed by another transformation, R_I . (2 marks)
- (c) Describe geometrically the transformation represented by
- (i) $R_p = \begin{pmatrix} 0 & -1 \\ 1 & 0 \end{pmatrix}$
 - (ii) $E = \begin{pmatrix} 2 & 0 \\ 0 & 2 \end{pmatrix}$ (4 marks)
- (d) On the **answer sheet provided**, using a scale of 1 cm to represent 1 unit on each axis, draw the pentagon $ABCDE$ with vertices $A(1, 2)$, $B(4, 2)$, $C(4, 5)$, $D(2, 6)$ and $E(1, 5)$. (1 mark)
- (e) Draw the image of $ABCDE$ under the transformation represented by
- (i) R_p , and label that image $A'B'C'D'E'$
 - (ii) E , and label that image $A''B''C''D''E''$. (6 marks)

Total 15 marks

END OF TEST

TEST CODE **000592**

FORM TP 22119

MAY/JUNE 2002

CARIBBEAN EXAMINATIONS COUNCIL
SECONDARY EDUCATION CERTIFICATE
EXAMINATION
MATHEMATICS

Paper 02 - General Proficiency

Answer sheet for Question 14 (d) & (e).

Candidate number

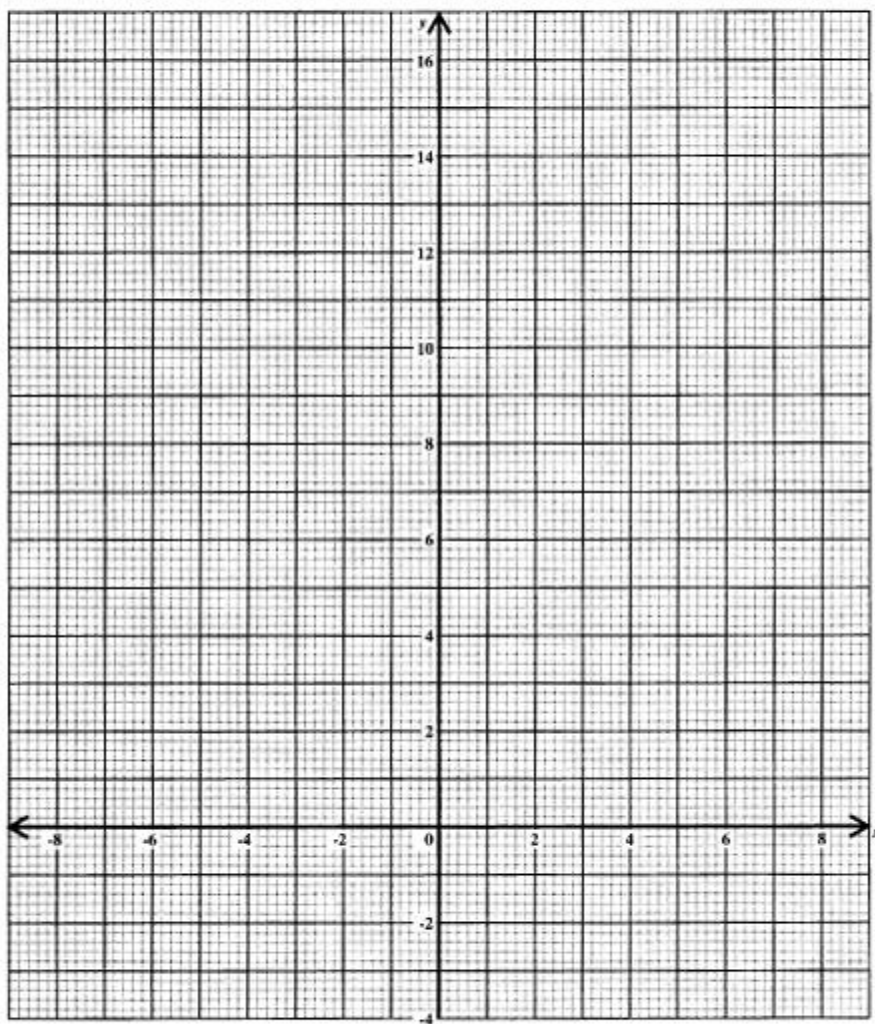

ATTACH THIS ANSWER SHEET TO YOUR ANSWER BOOKLET

000592/F 2002

FORM TP 22117

TEST CODE **000582**

MAY/JUNE 2002

CARIBBEAN EXAMINATIONS COUNCIL

**SECONDARY EDUCATION CERTIFICATE
EXAMINATION**

MATHEMATICS

Paper 02 - Basic Proficiency

2 hours 40 minutes



30 MAY 2002 (a.m.)

INSTRUCTIONS TO CANDIDATES

1. Answer **ALL** the questions.
2. Begin the answer for each question on a new page.
3. Full marks may not be awarded unless full working or explanation is shown with the answer.
4. Mathematical tables, formulae and graph paper are provided.
5. Mathematical instruments and silent electronic calculators may be used for this paper.
6. You are advised to use the first 10 minutes of the examination time to read through this paper. Writing may begin during this 10-minute period.

DO NOT TURN THIS PAGE UNTIL YOU ARE TOLD TO DO SO

Copyright © 2001 Caribbean Examinations Council.
All rights reserved.

000582/F 2002

Answer ALL the questions.

ALL working must be clearly shown.

1. (a) Calculate $366 \div 0.0012$ and write the answer
- (i) exactly
- (ii) in standard form. (3 marks)
- (b) Calculate
- $$1\frac{1}{6} \div \left(1\frac{2}{3} + 1\frac{1}{4}\right). \quad (4 \text{ marks})$$
- (c) The ratio of men : women at the beach was 6 : 7 respectively. There were 28 women.
Calculate the number of people on the beach. (3 marks)

Total 10 marks

2. (a) The cost price of a plot of land was \$20 000. The plot of land was sold for \$24 400.
Calculate the profit as a percentage of the cost price. (3 marks)
- (b) The table below shows how the cost of advertising in a local newspaper for one week is calculated.

Number of Words in the Advertisement	Cost of Advertisement
16 words or less	\$60.00
more than 16 words	\$60.00 plus \$3.00 per word for each word above 16 words.

Calculate

- (i) the cost of an advertisement of 12 words for one week.
- (ii) the cost of an advertisement of 24 words for one week.
- (iii) the number of words in an advertisement that costs \$198 for one week. (7 marks)

Total 10 marks

3. (a) Given that $m = 3$ and $n = -2$, calculate the value of

(i) mn^2

(ii) $(m + n)(m - n)$.

(5 marks)

- (b) Simplify

$$\frac{x-3}{3} + \frac{x+2}{4}$$

(2 marks)

- (c) Solve the equation

$$1 + 3(x - 1) = 4.$$

(3 marks)

Total 10 marks

4. (a) Solve the pair of simultaneous equations

$$\begin{aligned} 3x + y &= 1 \\ x - 2y &= 5. \end{aligned}$$

(4 marks)

- (b)

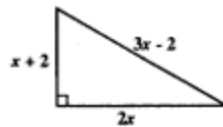

In the diagram above, **not drawn to scale**, the lengths, in cm, of the sides of the right-angled triangle are $x + 2$, $2x$, and $3x - 2$.

Write down, in its simplest form, an expression for

- (i) the perimeter of the triangle
(ii) the area of the triangle.

If the perimeter of the triangle is 24 cm, calculate

- (iii) the value of x
(iv) the length of the longest side of the triangle.

(6 marks)

Total 10 marks

5. (a) The exchange rates for the Barbados dollar in January 2001 are shown in the table below.

Currency	Exchange Rate
Pound Sterling £	2.94
US \$	1.99
EC \$	0.74
Belize \$	1.00

Using the exchange table, calculate how much a person would get for exchanging

- (i) £1 sterling into Barbados dollars
- (ii) \$30.00 Barbados into pound sterling
- (iii) \$300.00 US into Barbados dollars. (5 marks)

(b)

BASIC WEEK	
Time	Wages
40 hrs	\$320

The table above shows how a company pays its workers. Overtime is paid at time and a half.

Calculate

- (i) the basic hourly rate
- (ii) the overtime hourly rate
- (iii) the total wages for a worker who worked 10 hours overtime in one week
- (iv) the number of overtime hours for a worker who earned \$560 in one week. (5 marks)

Total 10 marks

6. (a)

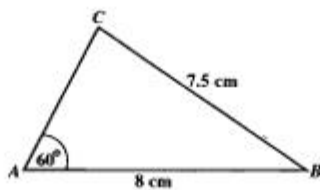

In the diagram above, **not drawn to scale**, $AB = 8$ cm, $BC = 7.5$ cm, and $\angle BAC = 60^\circ$.

- (i) **Using ruler and compasses**, construct triangle ABC .
- (ii) Measure and write down the size of angle ABC . (6 marks)

(b)

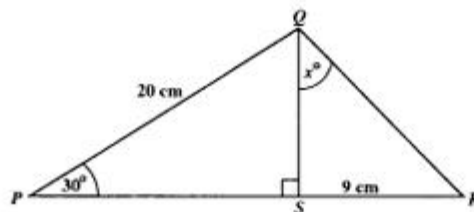

The diagram above shows triangle PQR , **not drawn to scale**.

$PQ = 20$ cm, $\angle QPR = 30^\circ$, QS is perpendicular to PR , $SR = 9$ cm, and $\angle SQR = x^\circ$.

Calculate

- (i) the length of QS
- (ii) the size of angle x to the nearest degree. (4 marks)

Total 10 marks

7. In a survey of 10 households, the number of children per household was found to be

4, 1, 5, 4, 3, 7, 2, 3, 4, 1

- (a) State the mode. (1 mark)
- (b) Calculate
- (i) the mean number of children per household
- (ii) the median number of children per household. (4 marks)
- (c) A researcher said; "The mode seems to be the best average to represent the data in this survey." Give ONE reason to support this statement. (1 mark)
- (d) Calculate the probability that a household chosen at random from those in the survey would have
- (i) exactly 4 children
- (ii) more than 4 children. (4 marks)

Total 10 marks

8. An answer sheet is provided for this question.

- (a) Write down the coordinates of the three vertices of ΔABC . (1 mark)
- (b) Describe fully the SINGLE transformation which maps ΔABC onto ΔPQR . (2 marks)
- (c) Plot the point $T(-5, 4)$ on the graph sheet. (1 mark)
- (d) Find the coordinates of N, M and L such that
- (i) $TN = 3TC$
- (ii) $TM = 3TB$
- (iii) $TL = 3TA$ (3 marks)
- (e) (i) On the answer sheet, draw ΔLMN .
- (ii) Describe FULLY the single transformation which maps ΔABC onto ΔLMN . (3 marks)

Total 10 marks

GO ON TO THE NEXT PAGE

9. (a) An aeroplane was scheduled to fly from Montego Bay to Miami at 16:40. Its departure was delayed for 35 minutes.

(i) Calculate the time at which it departed.

It landed at Miami 12 minutes before its scheduled arrival time of 23:07.

(ii) Calculate the time at which it landed

(iii) How many minutes did the plane take to fly from Montego Bay to Miami?

(4 marks)

- (b) Take $\pi = 3.14$ in this question.

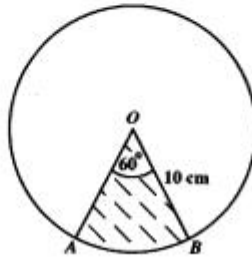

The diagram above, **not drawn to scale**, shows a circular piece of paper from which a sector has been cut. The centre of the circle is O , angle $AOB = 60^\circ$, and the radius of the circle is 10 cm.

Calculate

- (i) the length of the minor arc AB
 (ii) the area of the minor sector AOB
 (iii) the length of the chord AB .

(6 marks)

Total 10 marks

10. (a)

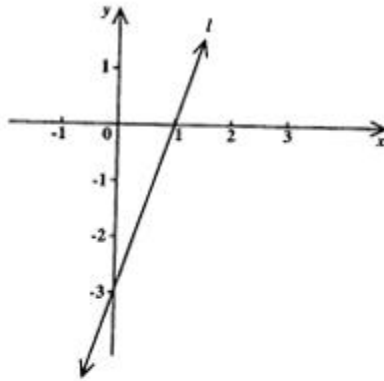

The diagram above, **not drawn to scale**, shows the straight line, l , which cuts the x -axis at $(1, 0)$ and the y -axis at $(0, -3)$.

- Determine the gradient of the line, l .
- Write down the equation of the line, l , in the form $y = mx + c$.

(4 marks)

(b) An answer sheet is provided for this question.

x	-2	-1	0	1	2	3
y	7	0			3	12

The table above shows some values of $y = 2x^2 - x - 3$ for values of x from -2 to 3 .

- Copy the table, calculate and insert the missing values of y .
- On the axes provided in the answer sheet, plot the points recorded in your completed table at (i) above, and draw a smooth curve through the points.
- Use your graph to find the values of x for which $2x^2 - x - 3 = 0$.

(6 marks)

Total 10 marks**END OF TEST**

TEST CODE **000582**

FORM TP 22117

MAY/JUNE 2002

CARIBBEAN EXAMINATIONS COUNCIL

SECONDARY EDUCATION CERTIFICATE

EXAMINATION

MATHEMATICS

Paper 02 - Basic Proficiency

Answer sheet for Question 8.

Candidate number

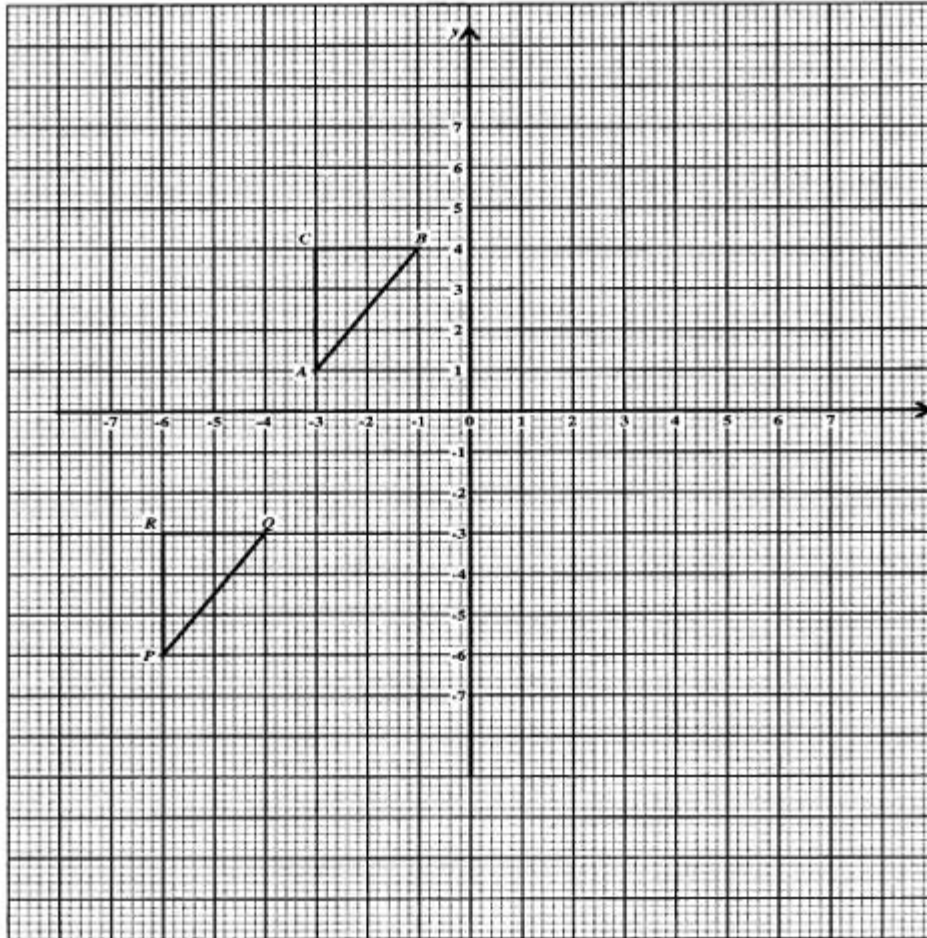

ATTACH THIS ANSWER SHEET TO YOUR ANSWER BOOKLET

000582/F 2002

TEST CODE **000582**

FORM TP 22117

MAY/JUNE 2002

CARIBBEAN EXAMINATIONS COUNCIL

SECONDARY EDUCATION CERTIFICATE

EXAMINATION

MATHEMATICS

Paper 02 - Basic Proficiency

Answer sheet for Question 10 (b).

Candidate number

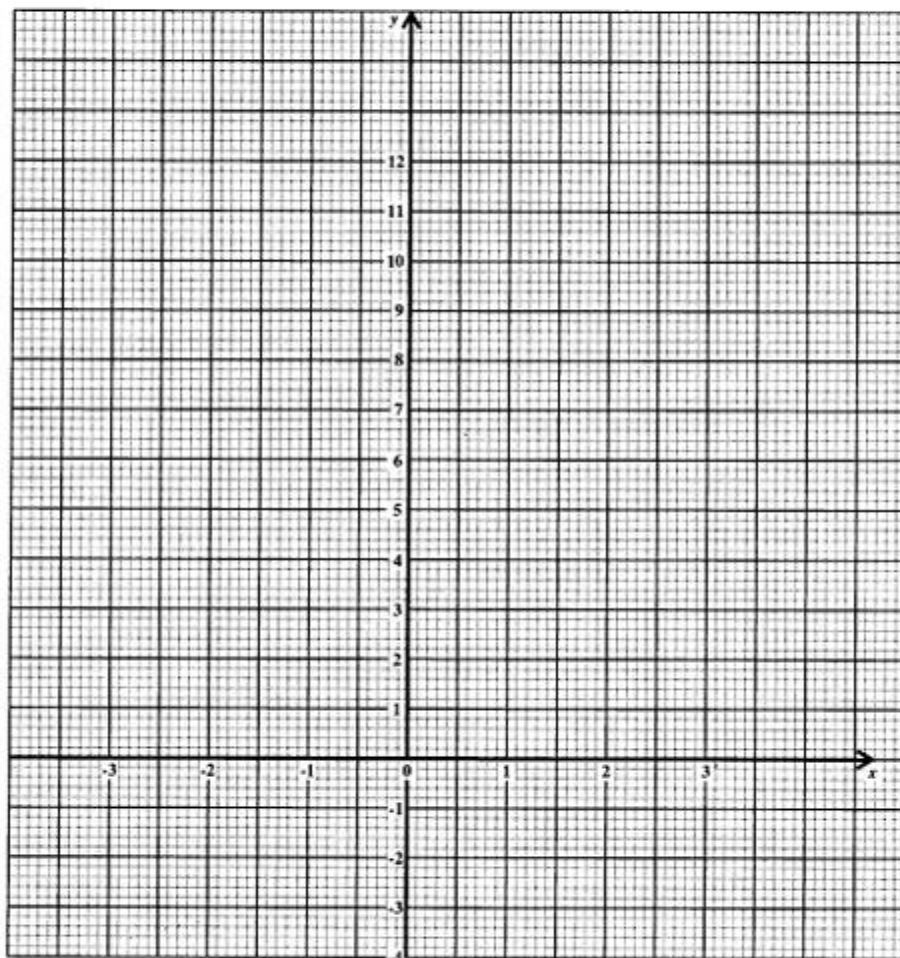

ATTACH THIS ANSWER SHEET TO YOUR ANSWER BOOKLET

000582/F 2002

FORM TP 23104

TEST CODE **000592**

MAY/JUNE 2003

CARIBBEAN EXAMINATIONS COUNCIL

**SECONDARY EDUCATION CERTIFICATE
EXAMINATION
MATHEMATICS**

Paper 02 - General Proficiency

2 hours 40 minutes

29 MAY 2003 (a.m.)

INSTRUCTIONS TO CANDIDATES

1. Answer ALL questions in Section I, and any TWO in Section II.
2. Begin the answer for EACH question on a NEW page.
3. ALL working must be shown CLEARLY.
4. Mathematical tables and graph paper are provided.
A list of formulae is provided on page 2 of this booklet.
5. Mathematical instruments are needed for this paper.
6. Silent electronic calculators may be used for this paper.
7. You are advised to use the first 10 minutes of the examination time to read through this paper.
Writing may begin during this 10-minute period.

DO NOT TURN THIS PAGE UNTIL YOU ARE TOLD TO DO SO

Copyright © 2002 Caribbean Examinations Council.
All rights reserved.

LIST OF FORMULAE

Volume of a prism $V = Ah$ where A is the area of a cross-section and h is the perpendicular length.

Volume of a right pyramid $V = \frac{1}{3}Ah$ where A is the area of the base and h is the perpendicular height.

Circumference $C = 2\pi r$ where r is the radius of the circle.

Area of a circle $A = \pi r^2$ where r is the radius of the circle.

Area of trapezium $A = \frac{1}{2}(a + b)h$ where a and b are the lengths of the parallel sides and h is the perpendicular distance between the parallel sides.

Roots of quadratic equations If $ax^2 + bx + c = 0$,
then $x = \frac{-b \pm \sqrt{b^2 - 4ac}}{2a}$

Trigonometric ratios

$$\sin \theta = \frac{\text{opposite side}}{\text{hypotenuse}}$$

$$\cos \theta = \frac{\text{adjacent side}}{\text{hypotenuse}}$$

$$\tan \theta = \frac{\text{opposite side}}{\text{adjacent side}}$$

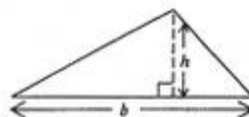
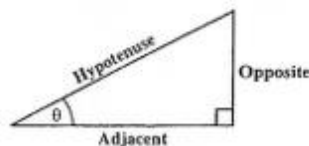

Area of triangle

Area of $\Delta = \frac{1}{2}bh$ where b is the length of the base and h is the perpendicular height

$$\text{Area of } \Delta ABC = \frac{1}{2}ab \sin C$$

$$\text{Area of } \Delta ABC = \sqrt{s(s-a)(s-b)(s-c)}$$

$$\text{where } s = \frac{a+b+c}{2}$$

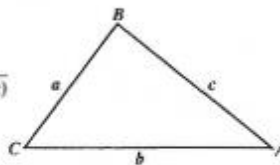

Sine rule

$$\frac{a}{\sin A} = \frac{b}{\sin B} = \frac{c}{\sin C}$$

Cosine rule

$$a^2 = b^2 + c^2 - 2bc \cos A$$

GO ON TO THE NEXT PAGE

SECTION I

Answer ALL the questions in this section.

ALL working must be shown clearly.

1. (a) Using a calculator, or otherwise, determine the EXACT value of:
- (i) $(1.7)^2 + (1.3)^2$
- (ii) $\frac{4.8 + 6.9}{1.3 \times 0.2}$ (5 marks)

Use the information given below to answer Parts (b) and (c)

RANDY'S VIDEO CLUB

Option A
Membership Fee for one year: \$80.00 Rental Fee: \$3.00 per video game

Option B
No Membership Fee Rental Fee: \$5.00 per video game

- (b) Carla rents 48 video games during one year.
What is the TOTAL cost if she chooses
- (i) Option A?
- (ii) Option B? (3 marks)
- (c) Carla estimates that she will be able to spend \$215.00 for renting video games during the next year. How many video games will she be able to rent using
- (i) Option A?
- (ii) Option B? (3 marks)

Total 11 marks

2. (a) Given $a = 2$, $b = -3$ and $c = 0$, evaluate
- (i) $4a - 2b + 3c$
- (ii) a^c . (3 marks)
- (b) Factorize completely
- (i) $7mp^2 + 14m^2p$
- (ii) $2y^2 - 11y + 15$. (4 marks)

GO ON TO THE NEXT PAGE

- (c) Write as a simple fraction in its LOWEST terms

$$\frac{2}{a-3} + \frac{3}{a} \quad (2 \text{ marks})$$

- (d) (i) Solve for
- x

$$12 \leq 3x + 5.$$

- (ii) If
- x
- is a member of the set of whole numbers, state the SMALLEST value of
- x
- which satisfies the inequality in (d) (i) above. (3 marks)

Total 12 marks

3. (a) The Universal set,
- U
- , is given as

$$U = \{1, 2, 3, \dots, 13, 14, 15\}.$$

The sets A and B are subsets of U such that

$$A = \{\text{Factors of } 12\}$$

$$B = \{\text{Multiples of } 3\}.$$

- (i) List the members of the set A .
- (ii) List the members of the set B .
- (iii) Represent the sets, A , B and U , on a Venn diagram.
- (iv) List the members of $(A \cup B)'$. (6 marks)

- (b) (i) Draw a line segment, PQ , 7 cm long.
- (ii) Using only a ruler, a pencil and a pair of compasses, construct a line segment, LM , the perpendicular bisector of PQ , such that
 LM cuts PQ at O , and $OL = OM = 4$ cm.
- (iii) Form parallelogram $PLQM$ by joining the points P , L , Q and M .
- (iv) Measure and state the size of the angle MPL .
- (v) What type of parallelogram is $PLQM$? Give a reason for your answer.

(6 marks)

Total 12 marks

4. (a) Triangle DEF , shown below, undergoes a rotation such that its image is triangle $D'E'F'$.

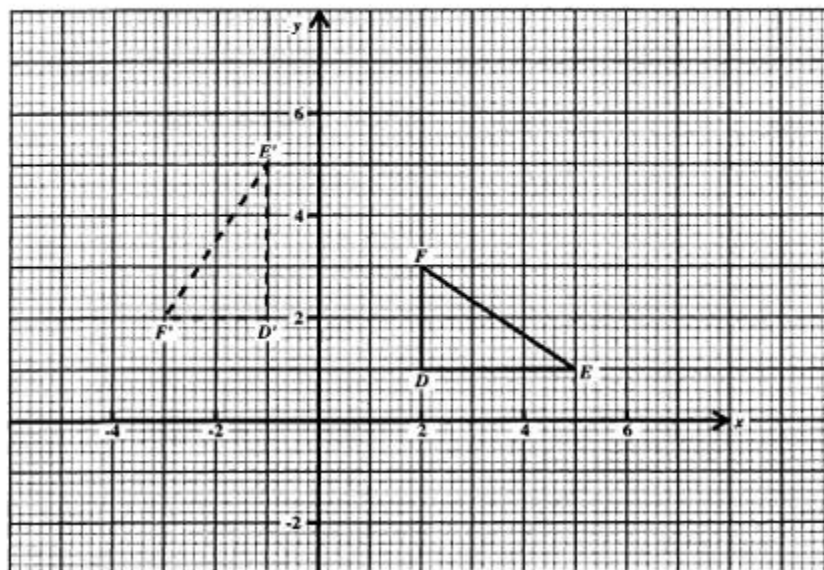

- (i) Describe COMPLETELY this rotation by stating
- the coordinates of the centre
 - the direction of turn
 - the size of the angle turned.
- (ii) Triangle DEF is mapped onto triangle ABC under a translation, $T = \begin{pmatrix} -6 \\ -3 \end{pmatrix}$.
State the coordinates of A , B and C , the images of D , E and F , under T .
(6 marks)

- (b) The figure below, **not drawn to scale**, represents the journey of an aircraft flying from Y to X and then from X to Z .

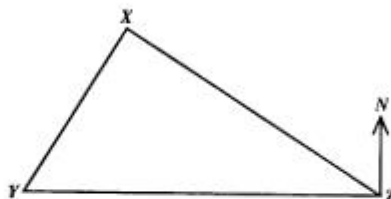

The bearing of X from Y is 035° .

The bearing of Z from X is 125° .

Z is due east of Y .

- (i) Copy and complete the diagram, showing CLEARLY the bearings 035° and 125° .
- (ii) Determine the size of the angle YXZ .
- (iii) Calculate, to the NEAREST whole number, the distance YZ given that $YX = 100$ km. (6 marks)

Total 12 marks

5. The graph below represents the function
 $f(x) = x^2 - 3x - 3$.

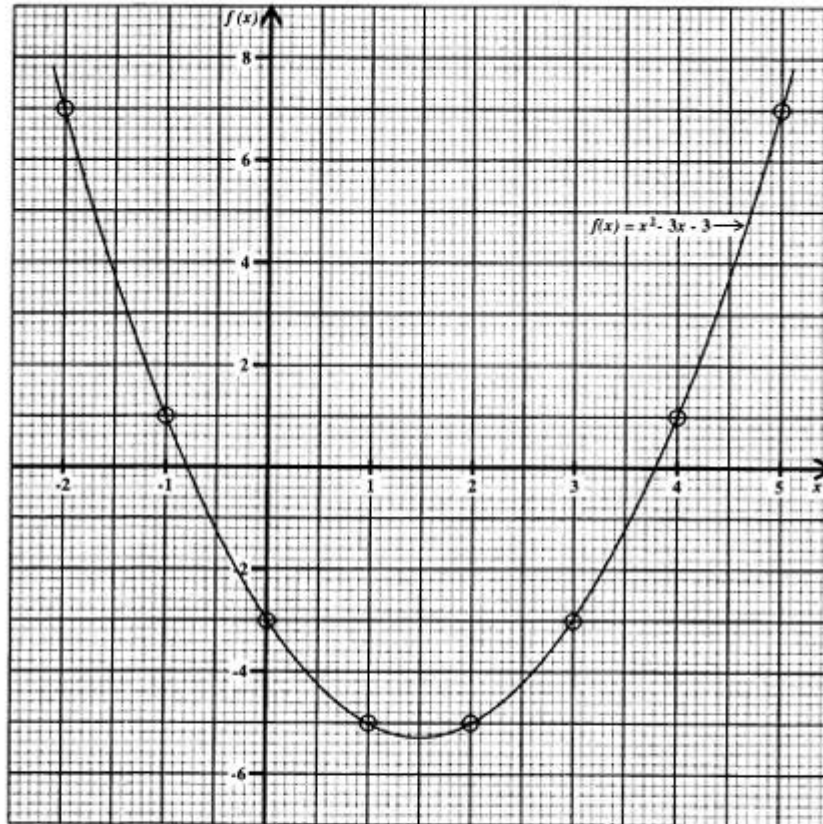

Use the graph to determine

- | | | |
|-----|---|------------|
| (a) | the value of $f(x)$ when $x = 2$ | (1 mark) |
| (b) | the value of $f(x)$ when $x = -1.5$ | (1 mark) |
| (c) | the values of x for which $f(x) = 0$ | (2 marks) |
| (d) | the minimum value of $f(x)$ | (1 mark) |
| (e) | the value of x at which $f(x)$ is a minimum. | (1 mark) |
| (f) | the solution of $x^2 - 3x - 3 = 5$ | (2 marks) |
| (g) | the interval on the domain for which $f(x)$ is less than -3 . | (2 marks) |

Total 10 marks

6. (a) The triangular prism, shown in the diagram below, **not drawn to scale**, is 18 cm long. Triangle GHI has a height of 3 cm, $HI = 8$ cm and $GH = GI$.

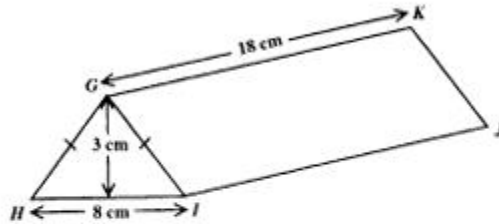

Calculate

- the area of triangle GHI
 - the volume of the triangular prism
 - the length of GI
 - the TOTAL surface area of the prism. (8 marks)
- (b) The triangular prism is melted down and made into a cube.
Calculate the length of an edge of the cube. (3 marks)

Total 11 marks

7. The height, in centimetres, of a sample of seedlings were recorded and grouped as shown below.



Height (cm)	3 – 7	8 – 12	13 – 17	18 – 22	23 – 27
Number of Seedlings	5	16	23	12	4

- (a) Calculate
- the TOTAL number of seedlings in the sample
 - an estimate of the mean height of the seedlings in the sample. (5 marks)
- (b) Using a scale of 2 cm to represent a height of 5 cm on the x -axis, and 2 cm to represent 5 seedlings on the y -axis, draw on graph paper the frequency polygon to represent the data given in the table. (5 marks)
- (c) Calculate the probability that a seedling, selected at random, measures at most 12 cm in height. (2 marks)

Total 12 marks

GO ON TO THE NEXT PAGE

8. The table below shows a sequence of shapes made from squares with sides of 1 unit.

Shape	Area of Shape	Perimeter of Shape
	1	4
	2	6
	3	8

- (a) **On the answer sheet provided**, draw the next TWO shapes to continue the sequence.
- (b) For EACH shape drawn, in Part (a), complete the table by stating
- the area of the shape
 - the perimeter of the shape. **(4 marks)**
- (c) A shape in the sequence has an area of 12 square units. What is the perimeter of this shape? **(2 marks)**
- (d) A shape in the sequence has a perimeter of 40 units. What is the area of this shape? **(2 marks)**
- (e) **On the answer sheet provided**, draw TWO shapes EACH made up of 4 unit squares so that one has a perimeter of 8 units and the other has a perimeter of 16 units. **(2 marks)**

Total 10 marks

SECTION II

Answer TWO questions in this section.

ALGEBRA AND RELATIONS, FUNCTIONS AND GRAPHS

9. (a) Given that $m + l = m^2 - lm$,
- (i) evaluate $5 * 3$
- (ii) solve for g given that $g * 4 = -3$. (5 marks)
- (b) An athlete runs on a track so that his distance, d metres, from the starting point after t seconds is as shown in the table below.

Time (seconds), t	0	2	4	6	8	10
Distance (metres), d	0	14	40	74	94	100

- (i) a) Using a horizontal scale of 1 cm to represent 1 second and a vertical scale of 1 cm to represent 10 metres, construct a distance-time graph to show the motion of the athlete.
- b) Draw a smooth curve through all the plotted points.
- (ii) Use your graph to estimate
- a) the distance travelled by the athlete after 3 seconds
- b) the average speed of the athlete during the interval $t = 6$ seconds to $t = 8$ seconds
- c) the speed of the athlete 6 seconds after leaving the starting point.

(10 marks)

Total 15 marks

10. (a) Solve for p and r given

$$3p + 2r = 7$$

$$p^2 - 2r = 11.$$

(5 marks)

- (b) Two functions, g and h , are defined as

$$g : x \rightarrow \frac{2x + 3}{x - 4} \text{ and}$$

$$h : x \rightarrow \frac{1}{x}.$$

Calculate

- (i) the value of $g(7)$
(ii) the value of x for which $g(x) = 6$.

Write expressions for

- (iii) $hg(x)$
(iv) $g^{-1}(x)$.

(10 marks)

Total 15 marks

GEOMETRY AND TRIGONOMETRY

11. In the diagram below, **not drawn to scale**, MC and MD are tangents of the circle whose centre is at O . Angle COD measures 96° .

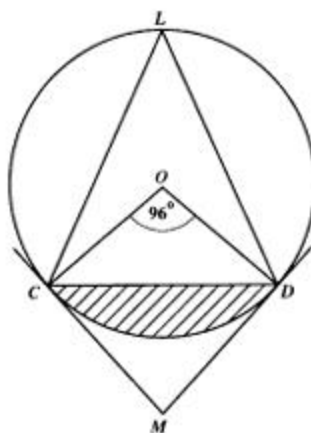

- (a) Calculate, giving reasons for your answer, the size of
- angle MCD
 - angle CMD . (5 marks)
- (b) Explain why the quadrilateral $OCMD$ is cyclic. (3 marks)
- (c) Given that the radius of the circle shown in the diagram above is 6.5 cm, calculate
- the area of triangle OCD
 - the area of the shaded segment of the circle. (7 marks)
[Use $\pi = 3.14$]

Total 15 marks

GO ON TO THE NEXT PAGE

12.

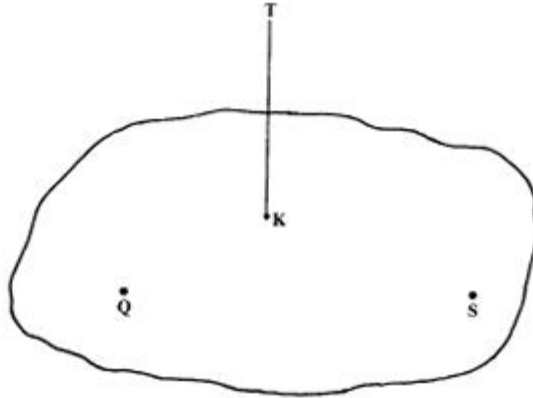

TK is a vertical tower, 10 metres high, standing on a horizontal plane QKS . Q and S are markers placed on the horizontal plane and angle QKS measures 112° . The angles of elevation of the top of the tower, T , from Q and S are 14° and 21° respectively.

- (a) Draw a diagram to represent the information, CLEARLY showing
- the line segment which represents 10 metres.
 - the angles whose measures are 14° , 21° and 112°
 - TWO right angles. (6 marks)
- (b) Calculate, to the NEAREST metre, the distance
- QK
 - SK
 - QS . (6 marks)
- (c) A vertical pole 4 m high is placed at Q . An instrument placed on the top of this pole measures the angle of elevation of the top of the tower. Calculate the size of this angle of elevation. (3 marks)

Total 15 marks

VECTORS AND MATRICES

13.

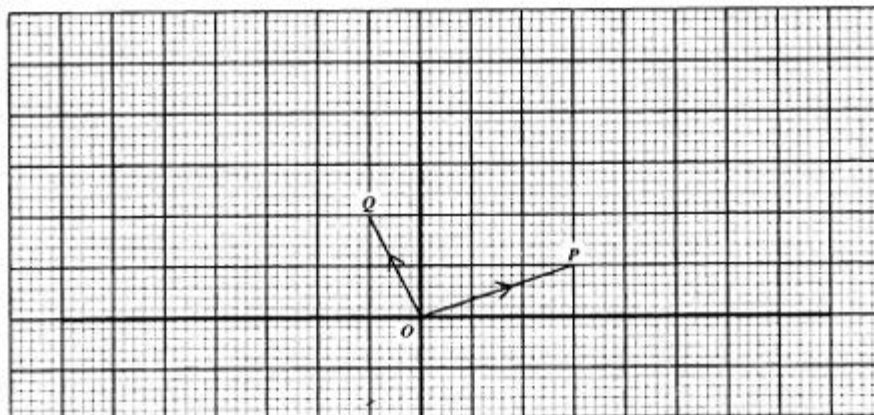

In the diagram above, the position vectors, \vec{OP} and \vec{OQ} , are given as

$$\vec{OP} = \mathbf{p} \text{ and } \vec{OQ} = \mathbf{q}.$$

- (a) Copy the diagram on graph paper and draw and label the vectors \vec{OW} and \vec{OE} such that $\vec{OW} = 2\mathbf{p}$ and $\vec{OE} = 2\mathbf{p} - \mathbf{q}$. (4 marks)
- (b) (i) Write down in terms of \mathbf{p} and \mathbf{q} , the vectors \vec{PQ} and \vec{PE} .
 (ii) Hence, state the relationship between \vec{PQ} and \vec{PE} . (4 marks)
- (c) The point D is such that $\vec{OD} = \vec{QE}$.
 (i) Write down, in terms of \mathbf{p} and \mathbf{q} , the vector \vec{OD} .
 (ii) Hence, state the coordinates of D . (4 marks)
- (d) Calculate the magnitude of the vector \vec{OW} . (3 marks)

Total 15 marks

GO ON TO THE NEXT PAGE

14. (a) Using a scale of 1 cm to represent 1 unit on BOTH the x and y -axes, draw on graph paper the triangle PQR and $P'Q'R'$ such that $P(-3, -2)$, $Q(-2, -2)$, $R(-2, -4)$ and $P'(6, 4)$, $Q'(4, 4)$ and $R'(4, 8)$. (3 marks)
- (b) Describe FULLY the transformation, G , which maps triangle PQR onto triangle $P'Q'R'$. (3 marks)
- (c) The transformation, M , is a reflection in the line $y = -x$.
On the same diagram, draw and label the triangle $P''Q''R''$, the image of triangle $P'Q'R'$ under the transformation M . (3 marks)
- (d) Write down the 2×2 matrix for
- (i) transformation G
 - (ii) transformation M
 - (iii) transformation G followed by M . (6 marks)

Total 15 marks

END OF TEST

TEST CODE **000592**

MAY/JUNE 2003

FORM TP 23104



**CARIBBEAN EXAMINATIONS COUNCIL
SECONDARY EDUCATION CERTIFICATE
EXAMINATION
MATHEMATICS**

Paper 02 - General Proficiency

Answer sheet for Question 8 (a) and (e).

Candidate number

(a)

Shape	Area of Shape	Perimeter of Shape
	1	4
	2	6
	3	8

(e)

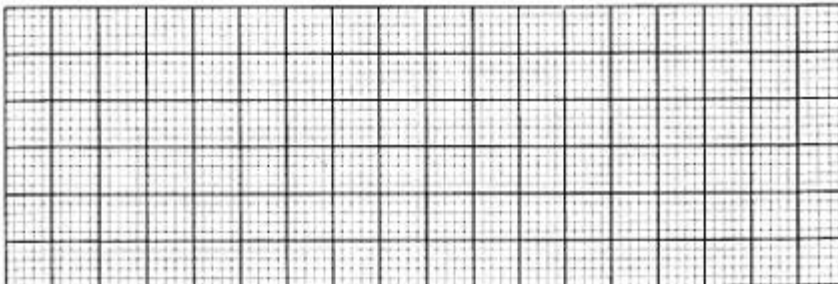

ATTACH THIS ANSWER SHEET TO YOUR ANSWER BOOKLET
000592/F 2003

FORM TP 23102

TEST CODE **000582**

MAY/JUNE 2003

CARIBBEAN EXAMINATIONS COUNCIL

**SECONDARY EDUCATION CERTIFICATE
EXAMINATION**

MATHEMATICS

Paper 02 - Basic Proficiency

2 hours 40 minutes



29 MAY 2003 (a.m.)

INSTRUCTIONS TO CANDIDATES

1. Answer **ALL** the questions.
2. Begin the answer for **EACH** question on a **NEW** page.
3. **ALL** working must be shown **CLEARLY**.
4. Mathematical tables and graph paper are provided.
A list of formulae is provided on page 2 of this booklet.
5. Mathematical instruments are needed for this paper.
6. Silent electronic calculators may be used for this paper.
7. You are advised to use the first 10 minutes of the examination time to read through this paper.
Writing may begin during this 10-minute period.

DO NOT TURN THIS PAGE UNTIL YOU ARE TOLD TO DO SO

Copyright © 2002 Caribbean Examinations Council.
All rights reserved.

000582/F 2003

LIST OF FORMULAE

Volume of a prism $V = Ah$ where A is the area of a cross-section and h is the perpendicular length.

Volume of a right pyramid $V = \frac{1}{3}Ah$ where A is the area of the base and h is the perpendicular height.

Circumference $C = 2\pi r$ where r is the radius of the circle.

Area of a circle $A = \pi r^2$ where r is the radius of the circle.

Area of trapezium $A = \frac{1}{2}(a + b)h$ where a and b are the lengths of the parallel sides and h is the perpendicular distance between the parallel sides.

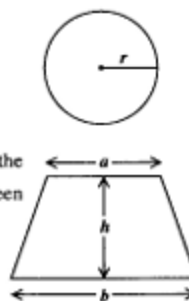

Roots of quadratic equations If $ax^2 + bx + c = 0$,
then $x = \frac{-b \pm \sqrt{b^2 - 4ac}}{2a}$

Trigonometric ratios $\sin \theta = \frac{\text{opposite side}}{\text{hypotenuse}}$

$$\cos \theta = \frac{\text{adjacent side}}{\text{hypotenuse}}$$

$$\tan \theta = \frac{\text{opposite side}}{\text{adjacent side}}$$

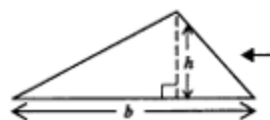
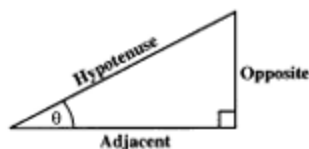

Area of triangle Area of $\Delta = \frac{1}{2}bh$ where b is the length of the base and h is the perpendicular height

Area of a sector Area = $\frac{\alpha}{360} \times \pi r^2$
where α is measured in degrees.

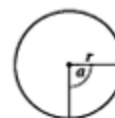

Arc length Arc length = $\frac{\alpha}{360} \times 2\pi r$

GO ON TO THE NEXT PAGE

Answer ALL the questions.

ALL working must be shown clearly.

1. (a) Calculate the EXACT value of

$$\frac{\frac{2}{3} + \frac{5}{12}}{1\frac{1}{4}}$$

giving the answer as a common fraction in its LOWEST terms. (4 marks)

- (b) A sum of \$30 was divided in the ratio 2 : 3. Calculate the amount of the LARGER share. (2 marks)

- (c) There are four athletes in a relay team. The masses of three of these athletes are 52.5 kg, 47.8 kg and 53.9 kg respectively. Calculate, in kg

- (i) the TOTAL mass of these three athletes
(ii) the mass of the FOURTH athlete if the mean mass of the relay team is 50.9 kg. (4 marks)

Total 10 marks

2. (a) Solve the equation

$$3x + 2 = 12 - 2x. \quad (3 \text{ marks})$$

- (b) Simplify the expression

$$3(5x + 2) - 2(4x + 3). \quad (3 \text{ marks})$$

- (c) Given that $f * g = f + g^2$,

calculate the value of

$$5 * 2. \quad (2 \text{ marks})$$

- (d) Write down an expression for the TOTAL cost, in dollars, of 8 metres of fabric at x dollars per metre and y reels of thread at 2 dollars per reel. (2 marks)

Total 10 marks

3. (a) Solve the simultaneous equations
 $3x - y = 10$
 $2x + y = 5.$ (5 marks)
- (b) Pam earns x dollars, Ryan earns $(x + 60)$ dollars and Rufus earns $(x - 10)$ dollars. Together, they earn a total of 530 dollars.
 Calculate
 (i) the value of x
 (ii) the amount Ryan earns. (5 marks)
- Total 10 marks**
4. (a) Use the information from the diagram below to answer this part of the question.

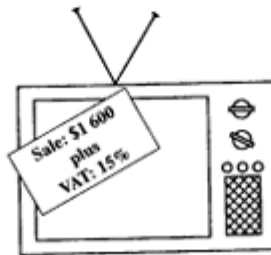

- (i) Calculate the TOTAL amount a customer pays for the television set.
 (ii) The sale price of \$1 600 is 20% LESS THAN the original price.
 Calculate the ORIGINAL price of the television set. (6 marks)
- (b) The monthly water bill for domestic users is calculated from information shown in the table below.

Fixed charge	\$15
Charge per gallon	2 cents

Calculate the TOTAL amount of the bill for a month when a consumer used 3850 gallons.
 (4 marks)

Total 10 marks

5. Use $\pi = 3.14$

The figure below, drawn to scale, on a square centimetre grid, is made up of a triangle and a semi-circle joined together.

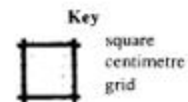
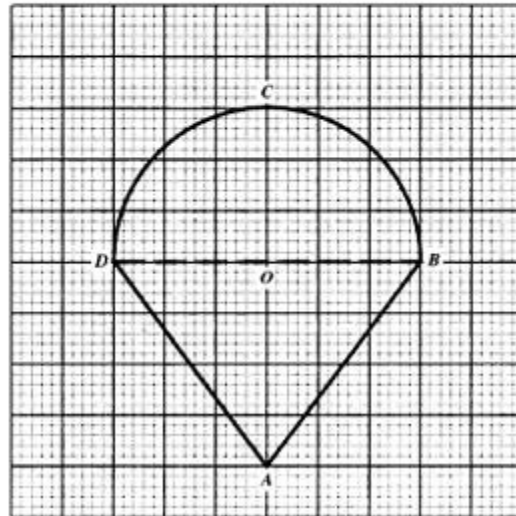

- (a) Write down, to the NEAREST centimetre, the length of
- the radius of the semi-circle
 - the line segment AO . (2 marks)
- (b) Determine the length of the line segment AB . (1 mark)
- (c) Using $\pi = 3.14$, calculate
- the perimeter of the figure $ABCD$
 - the area of the figure $ABCD$. (7 marks)

Total 10 marks

6. An answer sheet is provided for this question.

The figure below shows triangle PQR and its image $P'Q'R'$ after undergoing a certain transformation.

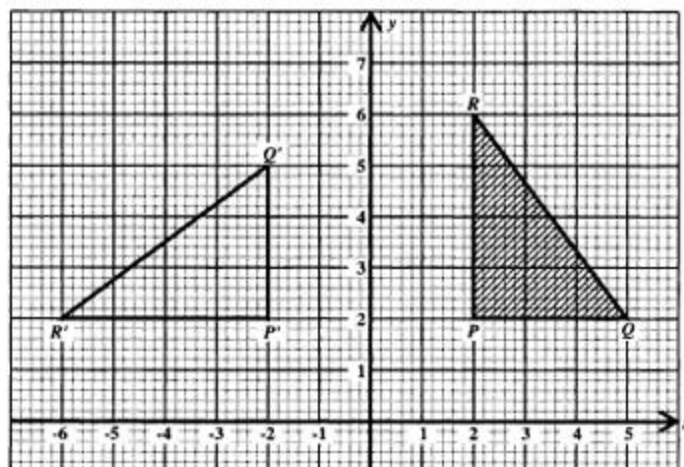

- (a) Write down the coordinates of the points P and P' . (2 marks)
- (b) A rotation maps ΔPQR onto $\Delta P'Q'R'$. State for this rotation the centre, the angle and the direction of rotation. (3 marks)
- (c) On the answer sheet provided, draw and label
- $\Delta P''Q''R''$, the image of ΔPQR , after a reflection in the x -axis
 - $\Delta P'''Q'''R'''$, the image of ΔPQR , after a translation by the vector $\begin{pmatrix} -6 \\ -6 \end{pmatrix}$

(5 marks)

Total 10 marks

7. A CD player is advertised at a price of \$1 200. It could be bought cash or by hire purchase. The table below shows the terms of payment.

Cash	Hire Purchase	
	Option 1	Option 2
Get 5% Discount	Pay down \$144, and \$100 monthly for 12 months	Pay down 15%, and \$95 monthly for 12 months

- (a) Calculate the ACTUAL cost of the CD player if it is bought
- cash
 - on hire purchase, Option 1
 - on hire purchase, Option 2. **(8 marks)**
- (b) Miranda has \$150 and wants to purchase the CD player. She can afford to pay AT MOST \$110 per month over twelve months. Which of the three forms of payment should she choose? Give TWO reasons for your answer. **(2 marks)**
- Total 10 marks**

8. (a) Port M , is due south of a lighthouse, L . A ship leaves Port M and sails 200 km on a bearing of 60° to Port K . Port K is directly east of the lighthouse.
- Sketch a diagram to represent this information. At L and K , draw dotted lines to show the direction of north.
 - Label CLEARLY on your diagram
 - the points L , M and K
 - the angle of 60° , which shows the bearing of K from M
 - the line segment representing 200 km. **(6 marks)**
- (b) Calculate, to the NEAREST kilometre, the distance LK . **(3 marks)**
- (c) Indicate on your diagram the angle, x , which shows the bearing of M from K . **(1 mark)**
- Total 10 marks**

GO ON TO THE NEXT PAGE

9. **An answer sheet is provided for part of this question.**

The marks gained by a group of students in a mathematics test are shown below.

11	20	24	27	29	34
13	22	26	27	31	36
17	23	26	28	32	38
19	23	27	28	33	39

- (a) Copy and complete the frequency table to show the distribution of the marks.

Marks	Frequency
10 – 14	2
15 – 19	
20 – 24	
25 – 29	
30 – 34	
35 – 39	3

(3 marks)

- (b) **On the answer sheet provided**, draw a histogram to represent the information in the completed frequency table from (a) above.

(5 marks)

- (c) Calculate the probability that a student chosen at random from those who wrote the test scored **LESS THAN 25** marks.

(2 marks)

Total 10 marks

10. (a) Given that $f(x) = x^2 + x - 2$, copy and complete the table below.

x	-3	-2	-1	0	1	2
$f(x)$	4		-2		0	

(2 marks)

- (b) Using 2 cm to represent 1 unit on both axes, draw the graph of $f(x) = x^2 + x - 2$ for $-3 \leq x \leq 2$. (4 marks)
- (c) On the graph of $f(x) = x^2 + x - 2$, draw the graph of $g(x) = x - 1$ using the values from the table shown below.

x	-2	3
$g(x)$	-3	2

(2 marks)

- (d) Using the graphs, write down the coordinates of the points where the two graphs intersect. (2 marks)

Total 10 marks**END OF TEST**

TEST CODE **000582**

FORM TP 23102

MAY/JUNE 2003

CARIBBEAN EXAMINATIONS COUNCIL
SECONDARY EDUCATION CERTIFICATE
EXAMINATION
MATHEMATICS

Paper 02 - Basic Proficiency

Answer sheet for Question 6.

Candidate number

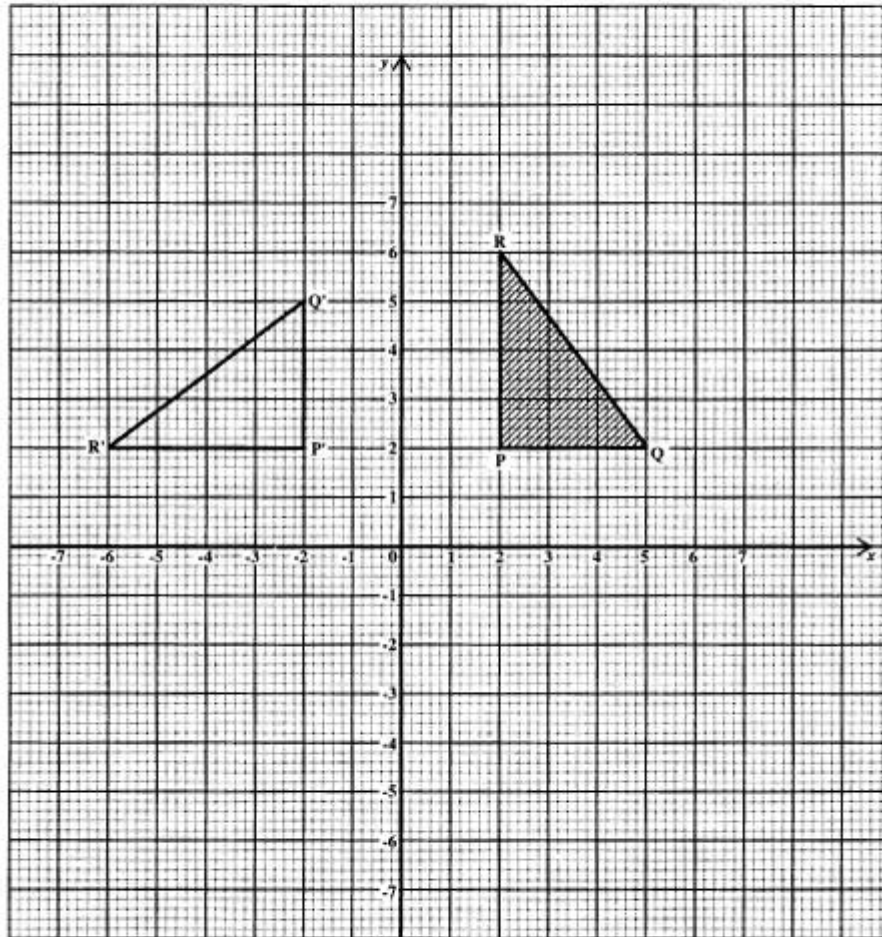

ATTACH THIS ANSWER SHEET TO YOUR ANSWER BOOKLET

000582/F 2003

TEST CODE **000582**

FORM TP 23102

MAY/JUNE 2003

CARIBBEAN EXAMINATIONS COUNCIL
SECONDARY EDUCATION CERTIFICATE
EXAMINATION
MATHEMATICS

Paper 02 - Basic Proficiency

Answer sheet for Question 9.

Candidate number

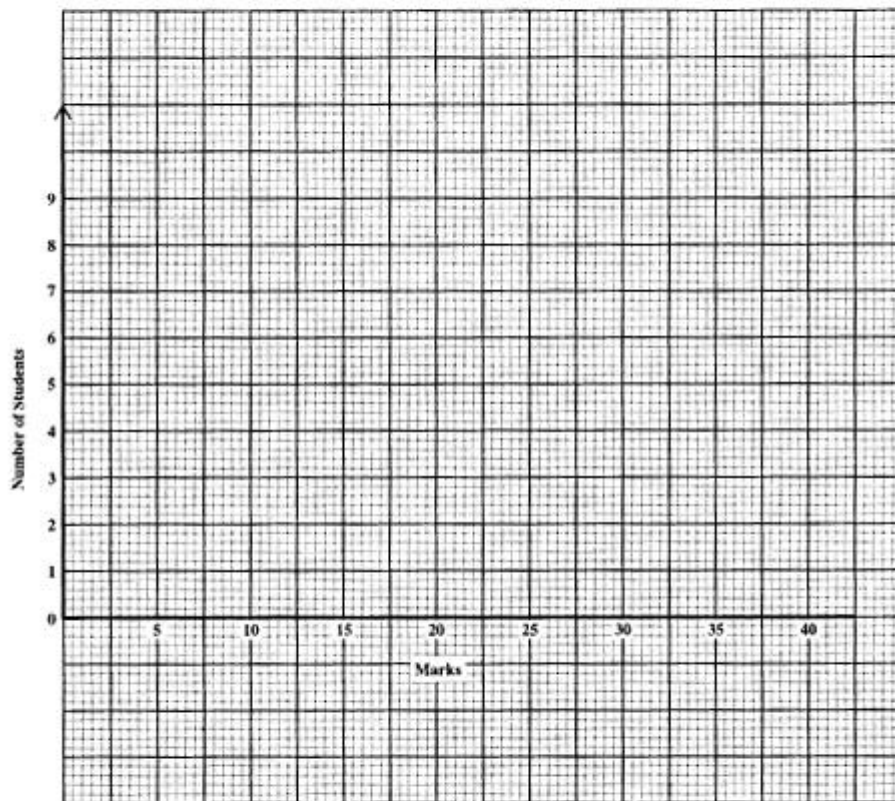

ATTACH THIS ANSWER SHEET TO YOUR ANSWER BOOKLET

000582/F 2003

FORM TP 2004101

TEST CODE **01234020**

MAY/JUNE 2004

**CARIBBEAN EXAMINATIONS COUNCIL
SECONDARY EDUCATION CERTIFICATE
EXAMINATION
MATHEMATICS**

Paper 02 – General Proficiency

2 hours 40 minutes

27 MAY 2004 (a.m.)

INSTRUCTIONS TO CANDIDATES

1. Answer ALL questions in Section I, and ANY TWO in Section II.
2. Write your answers in the booklet provided.
3. All working must be shown clearly.
4. A list of formulae is provided on page 2 of this booklet.

Examination Materials

Electronic calculator (non-programmable)
Geometry set
Mathematical tables (provided)
Graph paper (provided)

DO NOT TURN THIS PAGE UNTIL YOU ARE TOLD TO DO SO

Copyright © 2003 Caribbean Examinations Council.
All rights reserved.

01234020/F 2004

LIST OF FORMULAE

Volume of a prism $V = Ah$ where A is the area of a cross-section and h is the perpendicular length.

Volume of a right pyramid $V = \frac{1}{3}Ah$ where A is the area of the base and h is the perpendicular height.

Circumference $C = 2\pi r$ where r is the radius of the circle.

Area of a circle $A = \pi r^2$ where r is the radius of the circle.

Area of trapezium $A = \frac{1}{2}(a + b)h$ where a and b are the lengths of the parallel sides and h is the perpendicular distance between the parallel sides.

Roots of quadratic equations If $ax^2 + bx + c = 0$,
then $x = \frac{-b \pm \sqrt{b^2 - 4ac}}{2a}$

Trigonometric ratios $\sin \theta = \frac{\text{opposite side}}{\text{hypotenuse}}$

$$\cos \theta = \frac{\text{adjacent side}}{\text{hypotenuse}}$$

$$\tan \theta = \frac{\text{opposite side}}{\text{adjacent side}}$$

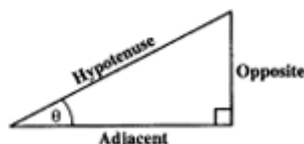

Area of triangle Area of $\Delta = \frac{1}{2}bh$ where b is the length of the base and h is the perpendicular height

$$\text{Area of } \Delta ABC = \frac{1}{2}ab \sin C$$

$$\text{Area of } \Delta ABC = \sqrt{s(s-a)(s-b)(s-c)}$$

$$\text{where } s = \frac{a+b+c}{2}$$

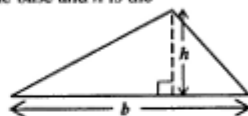

Sine rule $\frac{a}{\sin A} = \frac{b}{\sin B} = \frac{c}{\sin C}$

Cosine rule $a^2 = b^2 + c^2 - 2bc \cos A$

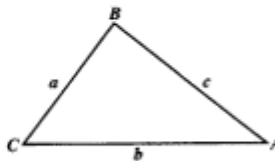

GO ON TO THE NEXT PAGE

SECTION I

Answer ALL the questions in this section.

All working must be clearly shown.

1. (a) Using a calculator, or otherwise, determine the exact value of
- (i) $2.3^2 + 4.1^2$
- (ii) $\frac{0.18}{0.6} - 0.003$
- (iii) $\frac{3\frac{1}{3} - 2\frac{3}{5}}{2\frac{1}{5}}$ (6 marks)
- (b) (i) Write your answer in Part (a) (i) correct to one significant figure.
- (ii) Write your answer in Part (a) (ii) in standard form. (2 marks)
- (c) (i) Mr Mitchell deposited \$40 000 in a bank and earned simple interest at 7% per annum for two years.
- Calculate the amount he will receive at the end of the two-year period.
- (ii) Mr Williams bought a plot of land for \$40 000. The value of the land appreciated by 7% each year.
- Calculate the value of the land after a period of two years. (4 marks)

Total 12 marks

2. (a) Simplify:
- (i) $\frac{x^2 - 1}{x - 1}$
- (ii) $\frac{4ab^2 + 2a^2b}{ab}$ (4 marks)
- (b) Express as a single fraction:
- $\frac{3p}{2} + \frac{q}{p}$. (2 marks)
- (c) Solve for x , given
- $3x^2 - 7x + 2 = 0$ (4 marks)

Total 10 marks

GO ON TO THE NEXT PAGE

3. (a) A club has 160 members, some of whom play tennis (T) or cricket (C) or both. 97 play tennis, 86 play cricket and 10 play neither, x play both tennis and cricket.
- Draw a Venn diagram to represent this information.
 - How many members play both tennis and cricket? **(5 marks)**
- (b) In a beauty contest, the scores awarded by eight judges were:
5.9 6.7 6.8 6.5 6.7 8.2 6.1 6.3
- Using the eight scores, determine:
 - the mean
 - the median
 - the mode
 - Only six scores are to be used. Which two scores may be omitted to leave the value of the **median** the same? **(6 marks)**

Total 11 marks

4. (a) (i) Using the formula
- $$t = \sqrt{\frac{5m}{12n}}$$
- calculate the value of t when $m = 20$ and $n = 48$.
- Express m as subject of the formula in (a) (i) above. **(5 marks)**
- (b) In the diagram below, **not drawn to scale**, $EFGH$ is a rectangle. The point D on HG is such that $ED = DG = 12$ cm and $\hat{GDF} = 43^\circ$.

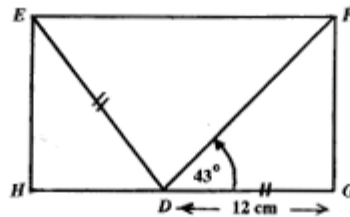

Calculate correct to one decimal place

- the length of GF
- the length of HD
- the size of the angle HDE . **(7 marks)**

Total 12 marks

GO ON TO THE NEXT PAGE

5. An answer sheet is provided for this question.

- (a) On the section of the answer sheet provided for 5 (a):
- (i) write down the coordinates of the point P
 - (ii) draw a line segment PQ through the point, P , such that the gradient of PQ is $\frac{-3}{2}$. **(3 marks)**
- (b) On the section of the answer sheet provided for 5 (b):
- (i) draw the reflection of quadrilateral A in the mirror line, labelled M_1 .
Label its image B .
 - (ii) draw the reflection of quadrilateral B in the mirror line, labelled M_2 .
Label its image C . **(4 marks)**
- (c) Complete the sentence in part (c) on your answer sheet, describing FULLY the single geometric transformation which maps quadrilateral A onto quadrilateral C . **(3 marks)**

Total 10 marks

6. The amount a plumber charges for services depends on the time taken to complete the repairs plus a fixed charge.

The graph below shows the charges in dollars (d) for repairs in terms of the number of minutes (t) taken to complete the repairs.

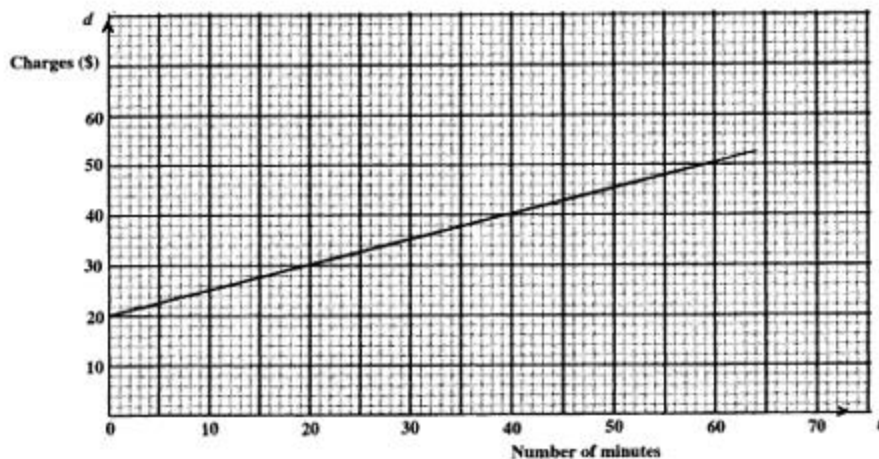

- (a) What was the charge for a plumbing job which took 20 minutes? **(1 mark)**
- (b) How many minutes were spent completing repairs that cost:
- \$38.00
 - \$20.00? **(2 marks)**
- (c) What is the amount of the fixed charge? **(1 mark)**
- (d) Calculate the gradient of the line. **(2 marks)**
- (e) Write down the equation of the line in terms of d and t . **(2 marks)**
- (f) Determine the length of time taken to complete a job for which the charge was \$78.00. **(3 marks)**

Total 11 marks

GO ON TO THE NEXT PAGE

7. (a) A piece of wire is bent in the form of a circle and it encloses an area of 154 cm^2 .

(i) Calculate:

- a) the radius of the circle
b) the circumference of the circle.

$$\left(\text{Use } \pi = \frac{22}{7}\right)$$

The same piece of wire is then bent in the form of a square.

(ii) Calculate the area enclosed by the square. **(6 marks)**

- (b) The diagram below shows a map of Baytime drawn on a grid of 1 cm squares. The scale of the map is 1:100 000.

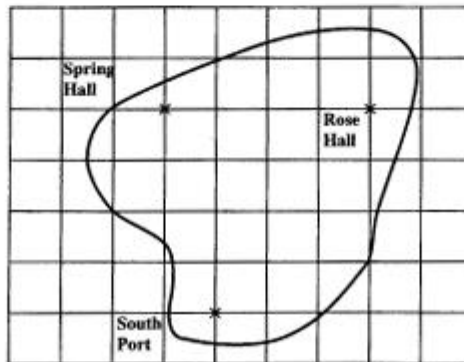

- (i) Find to the nearest km, the shortest distance between Rose Hall and South Port.
(ii) Determine the bearing of South Port from Spring Hall. **(6 marks)**

Total 12 marks

8. Two recipes for making chocolate drinks are shown in the table below.

	Cups of Milk	Cups of chocolate
Recipe A	3	2
Recipe B	2	1

- (a) What percent of the mixture using Recipe A is chocolate? **(2 marks)**
- (b) By showing suitable calculations, determine which of the two recipes, A or B, is richer in chocolate. **(2 marks)**
- (c) If the mixtures from Recipe A and Recipe B are combined, what is the percent of chocolate in the new mixture? **(2 marks)**
- (d) A vendor makes chocolate drink using Recipe A. 3 cups of milk and 2 cups of chocolate can make 6 bottles of chocolate drink. A cup of milk costs \$0.70 and a cup of chocolate costs \$1.15.
- (i) What is the cost of making 150 bottles of chocolate drink?
- (ii) What should be the selling price of each bottle of chocolate drink to make an overall profit of 20%? **(6 marks)**

Total 12 marks

SECTION II

Answer TWO questions in this section

ALGEBRA AND RELATIONS, FUNCTIONS AND GRAPHS

9. (a) The table below shows corresponding values for P and r .

P	m	4	62.5
r	0.2	2	n

Given that P varies directly as r^3 , calculate the values of m and n . (6 marks)

- (b) In the diagram below, **not drawn to scale**, $AKLM$ and $ASTJ$ are both rectangles.

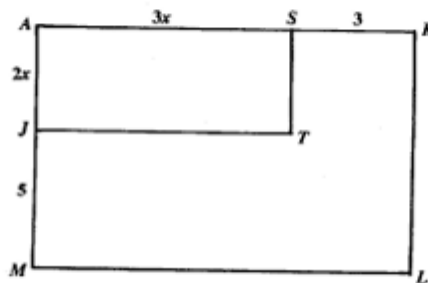

Given that $AS = 3x$ cm, $AJ = 2x$ cm, $SK = 3$ cm and $JM = 5$ cm

- Obtain an expression, in terms of x , for the area of rectangle $AKLM$.
- Given that the area of rectangle $AKLM$ is 60 cm², show that $2x^2 + 7x - 15 = 0$
- Hence, calculate the value of x and state the length of AK and AM . (9 marks)

Total 15 marks

10. A vendor buys x kg of peanuts and y kg of cashew nuts.

- (a) (i) To get a good bargain, she must buy a minimum of 10 kg of peanuts and a minimum of 5 kg of cashew nuts.

Write TWO inequalities which satisfy these conditions.

- (ii) She buys no more than 60 kg of nuts. Peanuts cost \$4.00 per kg and cashew nuts cost \$8.00 per kg and she spends at least \$200.

Write TWO inequalities which satisfy these conditions.

(5 marks)

- (b) Using a scale of 2 cm to represent 10 kg on each axis, draw the graph of the FOUR inequalities in (a) (i) and (a) (ii).

On your graph, shade ONLY the region which satisfies **all four** inequalities.

(6 marks)

- (c) The profit on the sale of 1 kg of peanuts is \$2.00 and on 1 kg of cashew nuts is \$5.00.

- (i) Using your graph, determine the number of kilograms of each type of nut the vendor must sell in order to make the maximum profit.

- (ii) Calculate the maximum profit.

(4 marks)

Total 15 marks

GO ON TO THE NEXT PAGE

GEOMETRY AND TRIGONOMETRY

11. (a) In the diagram below, VWZ and $WXYZ$ are two circles intersecting at W and Z . SVT is a tangent to the circle at V , VWX and VZY are straight lines, $\hat{TVY} = 78^\circ$ and $\hat{SVX} = 51^\circ$.

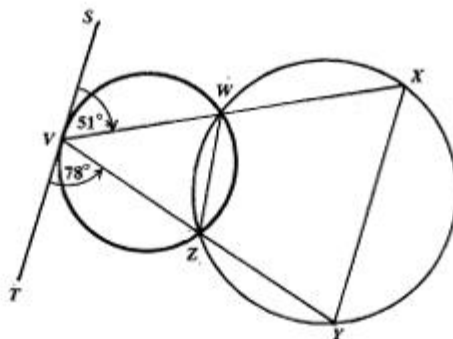

- (i) Calculate the size of EACH of the following angles, giving reasons for your answers.
- \hat{VZW}
 - \hat{XYZ}
- (b) (i) Draw a diagram to represent the information given below.

(4 marks)

Show clearly the north line in your diagram.

Town F is 50 km east of town G .

Town H is on a bearing of 040° from town F .

The distance from F to H is 65 km.

- (ii) Calculate, to the nearest kilometre, the actual distance GH .
- (iii) Calculate, to the nearest degree, the bearing of H from G . (11 marks)

Total 15 marks

12. (a) Given that $\sin \theta = \frac{\sqrt{3}}{2}$, $0^\circ \leq \theta \leq 90^\circ$.
- Express in fractional or surd form the value of $\cos \theta$.
 - Show that the area of triangle CDE is $150\sqrt{3}$ square units, where $CD = 30$ units and $DE = 20$ units.

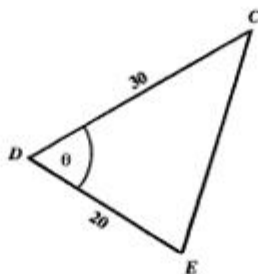

- Calculate the length of the side EC . (7 marks)

- (b) In this question, use $\pi = 3.14$ and assume the earth to be a sphere of radius 6 370 km.

The diagram below shows a sketch of the earth with the Greenwich Meridian and the Equator labelled.

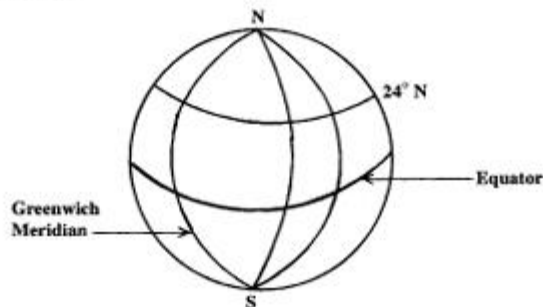

The towns A and B are both on the circle of latitude 24° N. The longitude of A is 108° E and the longitude of B is 75° E.

- Copy the sketch above of the earth and insert the points A and B on your diagram.

GO ON TO THE NEXT PAGE

- (ii) Calculate, correct to the nearest kilometre,
- the radius of the circle of latitude 24° N
 - the shortest distance between A and B , measured along the circle of latitude 24° N. **(8 marks)**

Total 15 marks

VECTORS AND MATRICES

13. The vertices of a quadrilateral, $OABC$, are $(0, 0)$, $(4, 2)$, $(6, 10)$ and $(2, 8)$ respectively.

Use a vector method to answer the questions which follow.

- (a) Write as a column vector, in the form $\begin{pmatrix} x \\ y \end{pmatrix}$, the vector
- \vec{OA}
 - \vec{CB} **(3 marks)**
- (b) Calculate $|\vec{OA}|$, the magnitude of \vec{OA} . **(1 mark)**
- (c)
- State two geometrical relationships between the line segments OA and CB .
 - Explain why $OABC$ is a parallelogram. **(4 marks)**
- (d) If M is the midpoint of the diagonal OB , and N is the midpoint of the diagonal AC , determine the position vector
- \vec{OM}
 - \vec{ON}

Hence, state one conclusion which can be made about the diagonals of the parallelogram $OABC$. **(7 marks)**

Total 15 marks

14. An answer sheet is provided for this question.

- (a) On the answer sheet provided, perform the following transformations:
- (i) Reflect triangle P in the y -axis.
Label its image Q .
 - (ii) Draw the line $y = x$ and reflect triangle Q in this line.
Label its image R . **(5 marks)**
 - (iii) Describe, in words, the single geometric transformation which maps triangle P onto triangle R . **(3 marks)**
 - (iv) Reflect triangle Q in the x -axis.
Label its image S .
 - (v) Write down the 2×2 matrix for the transformation which maps triangle P onto triangle S . **(3 marks)**
- (b) (i) Write down the 2×2 matrices for
- a) a reflection in the y -axis
 - b) a reflection in the line $y = x$.
- (ii) Using the two matrices in b (i) above, obtain a SINGLE matrix for a reflection in the y -axis followed by a reflection in the line $y = x$. **(4 marks)**

Total 15 marks**END OF TEST**

TEST CODE **01234020**

FORM TP 2004101

MAY/JUNE 2004

CARIBBEAN EXAMINATIONS COUNCIL

SECONDARY EDUCATION CERTIFICATE
EXAMINATION

MATHEMATICS

Paper 02 – General Proficiency

Answer Sheet for Question 5

Candidate Number

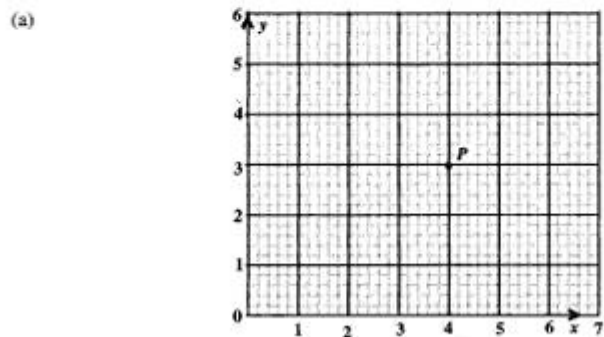

The coordinates of P are _____.

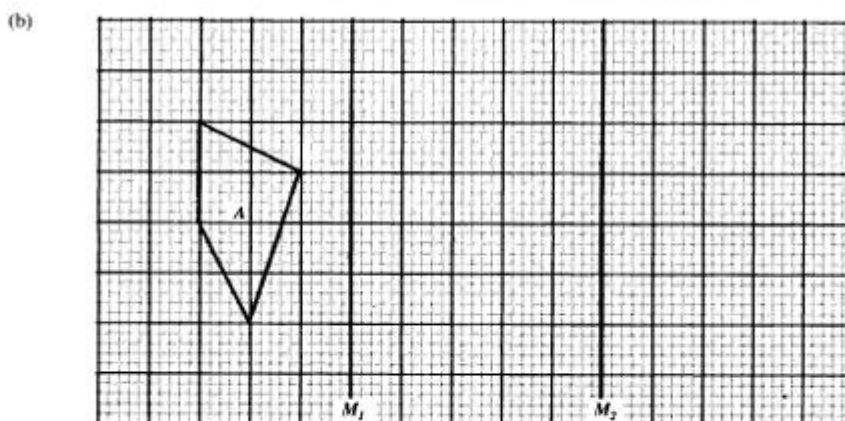

(c) The single geometric transformation which maps quadrilateral A onto quadrilateral C is

ATTACH THIS ANSWER SHEET TO YOUR ANSWER BOOKLET

TEST CODE **01234020**

FORM TP 2004101

MAY/JUNE 2004

CARIBBEAN EXAMINATIONS COUNCIL

SECONDARY EDUCATION CERTIFICATE
EXAMINATION

MATHEMATICS

Paper 02 – General Proficiency

Answer Sheet for Question 14

Candidate Number

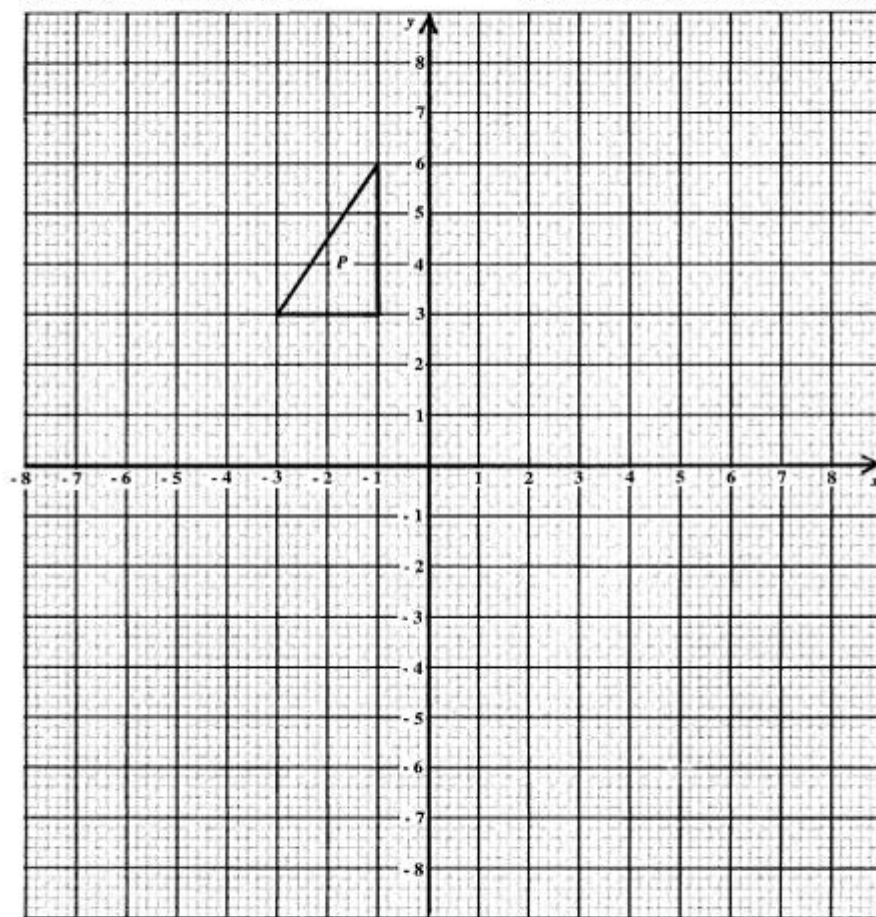

ATTACH THIS ANSWER SHEET TO YOUR ANSWER BOOKLET

01234020/F 2004

FORM TP 2004099

TEST CODE **01134020**

MAY/JUNE 2004

CARIBBEAN EXAMINATIONS COUNCIL

**SECONDARY EDUCATION CERTIFICATE
EXAMINATION**

MATHEMATICS

Paper 02 – Basic Proficiency

2 hours 40 minutes

27 MAY 2004 (a.m.)

B

INSTRUCTIONS TO CANDIDATES

1. Answer ALL questions.
2. Write your answers in the booklet provided.
3. All working must be shown clearly.
4. A list of formulae is provided on page 2 of this booklet.

Examination Materials

Electronic calculator (non-programmable)

Geometry set

Mathematical tables (provided)

Graph paper (provided)

DO NOT TURN THIS PAGE UNTIL YOU ARE TOLD TO DO SO

Copyright © 2003 Caribbean Examinations Council.
All rights reserved.

01134020/F 2004

LIST OF FORMULAE

Volume of a prism $V = Ah$ where A is the area of a cross-section and h is the perpendicular length.

Volume of a right pyramid $V = \frac{1}{3}Ah$ where A is the area of the base and h is the perpendicular height.

Circumference $C = 2\pi r$ where r is the radius of the circle.

Area of a circle $A = \pi r^2$ where r is the radius of the circle.

Area of trapezium $A = \frac{1}{2}(a + b)h$ where a and b are the lengths of the parallel sides and h is the perpendicular distance between the parallel sides.

Roots of quadratic equations If $ax^2 + bx + c = 0$,
then $x = \frac{-b \pm \sqrt{b^2 - 4ac}}{2a}$

Trigonometric ratios $\sin \theta = \frac{\text{opposite side}}{\text{hypotenuse}}$

$$\cos \theta = \frac{\text{adjacent side}}{\text{hypotenuse}}$$

$$\tan \theta = \frac{\text{opposite side}}{\text{adjacent side}}$$

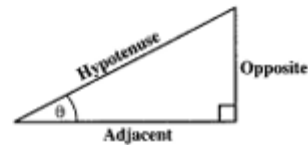

Area of triangle Area of $\Delta = \frac{1}{2}bh$ where b is the length of the base and h is the perpendicular height

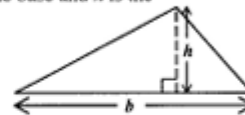

Area of sector Area = $\frac{\alpha}{360} \times \pi r^2$
where α is measured in degrees.

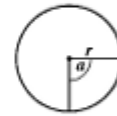

Length of Arc Arc length = $\frac{\alpha}{360} \times 2\pi r$

GO ON TO THE NEXT PAGE

SECTION I

All working must be clearly shown.

1. (a) Using a calculator, or otherwise, determine the value of $3.48 + \frac{3.335}{2.3}$ and write the answer
- (i) exactly
 - (ii) correct to one decimal place
 - (iii) correct to one significant figure. (3 marks)
- (b) Divide \$200 in the ratio 3 : 2. (2 marks)
- (c) Bacteria killed 70% of the fish in a pond. If 150 fish survived, calculate how many fish were originally in the pond. (2 marks)
- (d) Calculate $1\frac{3}{4} + (2\frac{1}{2} - 1\frac{1}{3})$ (3 marks)

Total 10 marks

2. (a) If $p = 3$ and $q = -2$, calculate the value of $4p + 5q$. (2 marks)
- (b) Write as a single fraction in its SIMPLEST form
- $$\frac{x+2}{2} + \frac{x-4}{3}$$
- (3 marks)
- (c) Solve the inequality
- $$6 - 3x \leq 12.$$
- (3 marks)
- (d) Simplify
- $$3(x - y) - 2(y - x)$$
- (2 marks)

Total 10 marks

GO ON TO THE NEXT PAGE

3. (a) Safe Loans Ltd. offers loans of \$6000, with repayments of \$350 each month for 18 months.
- Calculate:
- the interest, in dollars, paid on the loan
 - the interest as a percentage of the loan. **(3 marks)**
- (b) The cash price of a computer is \$696. The hire purchase price is 10% deposit and 15 monthly payments of \$45.
- Calculate how much more the hire purchase price is than the cash price. **(4 marks)**
- (c) Mrs Ray has a job for which the basic rate of pay is \$5.60 per hour, and the overtime rate of pay is \$8.40 per hour.
- During a certain week she earned \$165.20. She worked 3 hours overtime.
- Calculate
- the amount she earned at the basic rate
 - the number of hours she worked at the basic rate. **(3 marks)**
- Total 10 marks**

4. (a) The diagram below, **not drawn to scale**, shows parallel lines AB and CD intersected by the line EF .

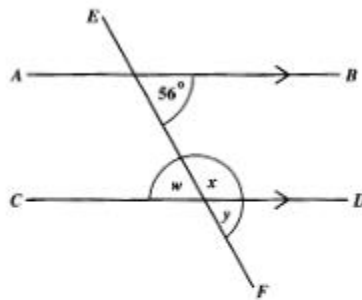

Calculate the size of the angle marked

- w
- x **(2 marks)**

- (b) The diagram below shows a circle ABC with centre O . AC is a diameter and $\angle ACB = 35^\circ$.

Calculate the size of $\angle ABO$.

(3 marks)

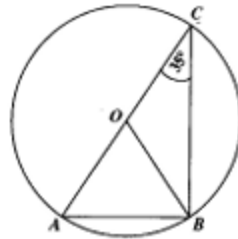

- (c) The figure below, **not drawn to scale**, consists of a rectangle $LKNM$ joined to a semicircle MJL .

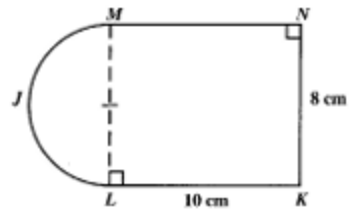

- (i) State the length of the radius of the semicircle.
- (ii) Using a protractor, a ruler and a pair of compasses, make an accurate **full-scale** drawing of the figure. (5 marks)

Total 10 marks

5. (a) An investor bought US \$6650 using EC dollars when the exchange rate was EC \$1.00 = US \$0.35. For this service, he paid the bank 1% of the amount of EC dollars he spent.
- (i) How much EC dollars did the investor spend to obtain US \$6650?
- A month later he converted the US \$6650 back to EC dollars when the exchange rate was EC \$1.00 = US \$0.38. For this service he paid the bank a fixed amount of EC \$200.
- (ii) What profit or loss did the investor make in EC dollars? **(6 marks)**
- (b) An antique vase is valued at \$400. Its value increases by 5% each year for 3 years.
- (i) Find the value after two years.
- (ii) Show that the value after three years is \$463.05. **(4 marks)**

Total 10 marks

6. The diagram below, **not drawn to scale**, shows a rectangle $ABCE$ joined along the edge EC to a quarter circle ECD , so that AED is a straight line. $AB = 7$ cm and $BC = 5$ cm.

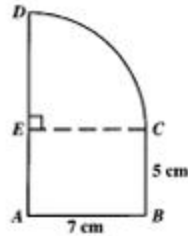

- (a) Write down the length of AD . **(1 mark)**
- (b) Use $\pi = \frac{22}{7}$.
- Calculate
- (i) the length of the arc CD
- (ii) the perimeter of the figure $ABCDE$.
- (iii) the area of the figure $ABCDE$. **(7 marks)**
- (c) If the diagram is drawn to a scale of 1:100, find the actual area of rectangle $ABCE$ in square metres. **(2 marks)**

Total 10 marks

GO ON TO THE NEXT PAGE

7. (a) Solve the following simultaneous equations for x and y :
- $$\begin{aligned}x + 2y &= 4 \\ 4x + 3y &= 1\end{aligned}$$
- (5 marks)**
- (b) Pearl had \$12 and Kurt had \$2. Each of them received \$ x for a job. Write an expression in terms of x for the amount of money
- Pearl now has
 - Kurt now has.
- After they were paid for the job, Pearl's amount of money was 3 times as much as Kurt's.
- Write an equation in terms of x to represent the information given.
 - Solve the equation.
 - How much money was Pearl paid for the job? **(5 marks)**

Total 10 marks

8. A ladder is 3.5 metres long. It is placed against a vertical wall so that its foot is on horizontal ground and it makes an angle of 48° with the ground.
- Draw a diagram which represents the information given. Label the diagram showing the ladder, the wall and the ground and insert all measurements given. **(2 marks)**
 - Calculate, to two significant figures,
 - the height the ladder reaches up the wall
 - the distance the foot of the ladder is from the wall. **(4 marks)**
 - The top of the ladder is lowered so that it reaches 1.75 m up the wall, still touching the wall.
Calculate the angle that the ladder now makes with the horizontal. **(4 marks)**

Total 10 marks

9. The marks obtained by 25 pupils on a test are shown below.

3	4	5	6	5
5	1	2	3	3
4	7	5	1	5
2	5	6	5	4
6	4	5	4	3

- (a) Copy and complete the frequency table below to present the information given above.

Marks	Frequency
1	2
2	2
3	4
4	—
5	—
6	3
7	1

(2 marks)

- (b) Using the frequency distribution, state

- the modal mark
- the median mark
- the range.

(3 marks)

- (c) On graph paper, draw a histogram to illustrate the frequency distribution. Use axes as labelled below.

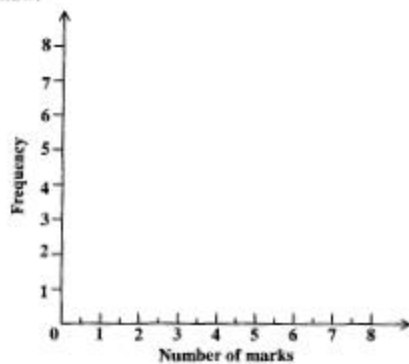

(3 marks)

- (d) A pupil is chosen at random from the group of pupils. What is the probability that the pupil's mark is greater than 5? (2 marks)

Total 10 marks

10. The cost of hiring a taxi consists of a basic charge plus a charge per km travelled.

The graph below shows the total cost in dollars (y) for the number of km travelled (x).

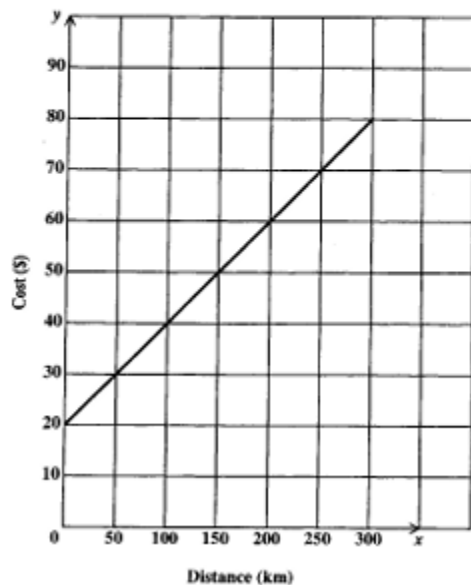

- (a) What is the cost of hiring a taxi to travel a distance of
- 250 km
 - 155 km? (2 marks)
- (b) What distance in km was travelled when the cost was \$40? (1 mark)
- (c) What is the amount of the basic charge? (1 mark)
- (d) Calculate the gradient of the line. (2 marks)
- (e) Write down the equation of the line in the form $y = mx + c$. (2 marks)
- (f) Calculate the cost of hiring a taxi to travel a distance of 330 km. (2 marks)

Total 10 marks

END OF TEST

C A R I B B E A N E X A M I N A T I O N S C O U N C I L

SECONDARY EDUCATION CERTIFICATE
EXAMINATION

SPECIMEN
MULTIPLE CHOICE QUESTIONS
FOR

MATHEMATICS

READ THE FOLLOWING DIRECTIONS CAREFULLY

Each item in this test has four suggested answers lettered (A), (B), (C), (D). Read each item you are about to answer and decide which choice is best.

Sample Item

$2a + 6a =$

- (A) $8a$
- (B) $8a^2$
- (C) $12a$
- (D) $12a^2$

Sample Answer



The best answer to this item is "8a", so answer space (A) has been shaded.

Copyright © 2004 Caribbean Examinations Council.
All rights reserved.

1. 0.045×10^{-3} in scientific notation is

- (A) 4.5×10^6
- (B) 4.5×10^5
- (C) 4.5×10^4
- (D) 4.5×10^1

2. The number 32747 written to 4 significant figures is

- (A) 32740
- (B) 32750
- (C) 3274
- (D) 3275

3. The sizes of the interior angles of a polygon are x° , $2x^\circ$, 60° , $3x^\circ$ and 36° . What is the value of x ?

- (A) 14
- (B) 16
- (C) 44
- (D) 74

4. Which of the following relations represents a one-to-one mapping?

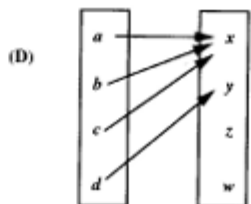
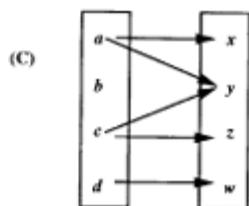
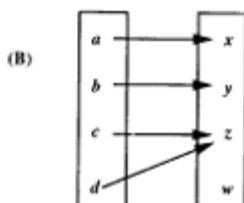
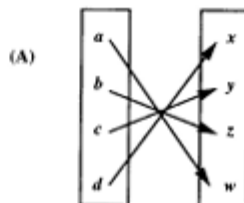

5. The expression $(3x - 2)(x + 1) =$
- (A) $3x^2 - x - 2$
(B) $3x^2 - x + 2$
(C) $3x^2 + x - 2$
(D) $3x^2 + x + 2$
6. The cost price of an article is \$40 and the profit is 20 per cent of the cost price. What is the selling price of the article?
- (A) \$40.20
(B) \$48.00
(C) \$50.00
(D) \$60.00
7. The number 3 754 expressed to the nearest hundred is
- (A) 3 700
(B) 3 750
(C) 3 800
(D) 4 000
8. Pineapples are sold at d cents per pound. The total weight of 3 pineapples is 5 pounds. What is the average cost of 1 pineapple?
- (A) $\frac{3d}{5}$ cents
(B) $\frac{5d}{3}$ cents
(C) $5d$ cents
(D) $15d$ cents
9. If m , a and c are constants, then the equation of a straight line may be written as
- (A) $y = mx + c$
(B) $y = \frac{c}{x}$
(C) $x^2 + y^2 = a^2$
(D) $y^2 = 4ax$
10. What is the value of $\frac{(5+2)^2}{5^2-2^2}$ in its simplest form?
- (A) $\frac{8}{21}$
(B) $\frac{7}{3}$
(C) $\frac{7}{2}$
(D) $\frac{49}{3}$
11. How much simple interest is due on a loan of \$120 for two years if the annual rate of interest is $5\frac{1}{2}$ per cent?
- (A) \$12.00
(B) \$13.20
(C) \$26.40
(D) \$33.00
12. 
- Hire Purchase Plan:**
Pay down \$60
\$55 monthly for 12 months
- Mr Jones purchases the TV advertised in the diagram by using the hire purchase plan instead of paying cash. How much more than \$600 does Mr Jones pay by using the hire purchase plan?
- (A) \$ 60
(B) \$105
(C) \$115
(D) \$120

13. A store charges 6% VAT on all sales. What is the total cost of a shirt marked at \$30?
- (A) \$28.20
 (B) \$31.80
 (C) \$33.84
 (D) \$36.00

14. Jake bought a shirt marked at \$80. He receives a 10 per cent discount. How much does he pay for the shirt?
- (A) \$54
 (B) \$70
 (C) \$72
 (D) \$74

15. $(0.1 + 0.01)(0.1 - 0.01) =$
- (A) 0.0001
 (B) 0.001
 (C) 0.009
 (D) 0.0099

16.

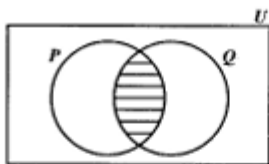

In the Venn diagram above, the shaded portion represents

- (A) $P \cup Q$
 (B) $P \cap Q'$
 (C) $P' \cap Q$
 (D) $P \cap Q$

17. The equation of the line which passes through the point (0, 2) and has a gradient of $\frac{1}{3}$ is

- (A) $y = 3x$
 (B) $y = 3x + 2$
 (C) $y = \frac{1}{3}x$
 (D) $y = \frac{1}{3}x + 2$

18.

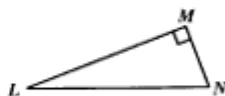

ΔLMN , above, is rotated anti-clockwise about L through 90 degrees. Which of the following is its likely image?

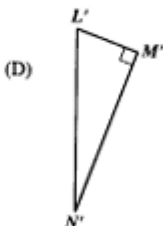
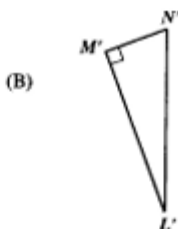

Item 19 refers to the chart shown below.

Rate on Fixed Deposits	
1975	7.8%
1976	7.5%

19. How much more interest would a fixed deposit of \$1 000 earn in 1975 than in 1976?
- (A) \$ 0.30
(B) \$ 3.00
(C) \$30.00
(D) \$33.00

20.

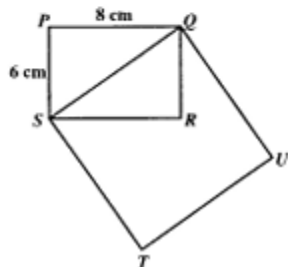

In the figure above, not drawn to scale, $PQRS$ is a rectangle in which $PQ = 8$ cm and $PS = 6$ cm. $QSTU$ is a square. The area of $QSTU$ is

- (A) 40 cm^2
(B) 48 cm^2
(C) 56 cm^2
(D) 100 cm^2

21. Which of the following sets has an infinite number of members?

- (A) {odd numbers between 10 and 20}
(B) {prime numbers between 10 and 20}
(C) {factors of 20}
(D) {multiples of 20}

22. Given that $2x + 6 = 7$, then $x =$

- (A) $-6\frac{1}{2}$
(B) $-\frac{1}{2}$
(C) $\frac{1}{2}$
(D) $6\frac{1}{2}$

23. How many litres of water would a container whose volume is 36 cm^3 hold?

- (A) 0.036
(B) 0.36
(C) 36
(D) 3600

GO ON TO THE NEXT PAGE

Items 24 - 26 refer to the graph below.

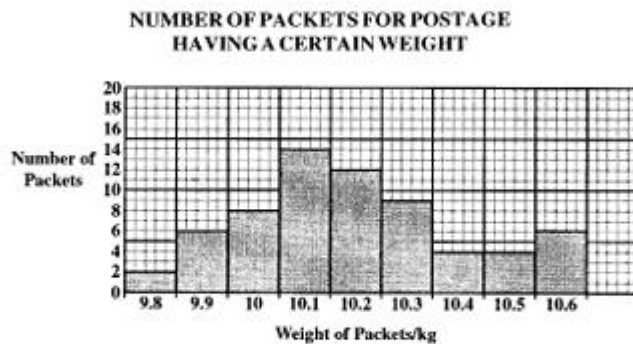

24. What is the frequency of the median weight?
- (A) 7
(B) 8
(C) 12
(D) 14
25. How many packets were weighed?
- (A) 9
(B) 14
(C) 65
(D) 92
26. What is the modal weight?
- (A) 9.9 kg
(B) 10.1 kg
(C) 10.2 kg
(D) 10.5 kg

27.

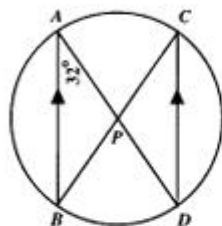

In the figure above, $AB \parallel CD$ and $\angle BAD = 32^\circ$. $\angle APC =$

- (A) 32°
(B) 64°
(C) 90°
(D) 116°

28. The width of a block of wood with rectangular cross-section is x cm. Its height is $\frac{2}{3}$ its width and its length is 4 times its height. What is its volume in cm^3 ?

- (A) $\frac{8x}{9}$
(B) $\frac{16x^3}{9}$
(C) $\frac{8x^3}{3}$
(D) $\frac{17x}{3}$

29. The mean of ten numbers is 58. If one of the numbers is 40, what is the mean of the other nine?

(A) 18
 (B) 60
 (C) 162
 (D) 540

30. The observation which occurs most frequently in a sample is the

(A) median
 (B) mean deviation
 (C) standard deviation
 (D) mode

31. A rectangular sheet of paper measures, to the nearest cm, 16 cm by 9 cm. What are the least possible values of its dimensions?

(A) 15.0 cm by 8.0 cm
 (B) 15.5 cm by 8.4 cm
 (C) 15.5 cm by 8.5 cm
 (D) 16.0 cm by 9.0 cm

32. The interest rate on investments in a bank decreased from 8½% per annum to 6% per annum. What is the difference in size of the annual interest on a deposit of \$2 000?

(A) \$ 30
 (B) \$ 50
 (C) \$120
 (D) \$170

33.

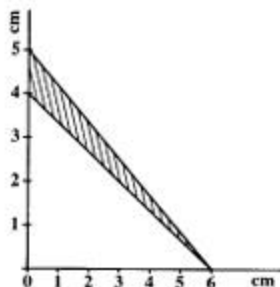

In the figure above, what is the area of the shaded region?

(A) 15 cm²
 (B) 12 cm²
 (C) 6 cm²
 (D) 3 cm²

34.

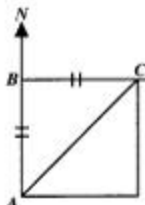

In the diagram, B is due north of A ; C is east of B , and $AB = BC$. What is the bearing of A from C ?

(A) 045°
 (B) 090°
 (C) 135°
 (D) 225°

35. The water authority charges \$10.00 per month for the meter rent, \$2.50 for the first 1 000 litres and \$0.10 for each additional 100 litres. What is the total bill for 2 500 litres used in one month?

(A) \$ 4.00
 (B) \$12.70
 (C) \$14.00
 (D) \$14.90

36.

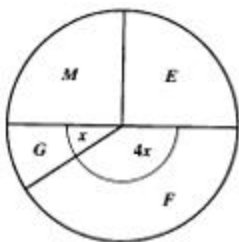

The pie chart above shows how a student used 10 hours per week for studying English (*E*), Mathematics (*M*), French (*F*) and Geography (*G*). The amount of hours spent studying French is approximately

- (A) 1
(B) 2
(C) 3
(D) 4

Item 37 refers to the table below which shows the relationship between the number of sides and number of diagonals of a polygon.

Sides	Diagonals
4	2
5	5
6	9
7	14
-	-
-	-
10	n

37. What is the value of n ?

- (A) 10
(B) 11
(C) 20
(D) 35

38. Seven times the product of two numbers, a and b , may be written as

- (A) $7ab$
(B) $7a + b$
(C) $7a + 7b$
(D) $49ab$

39. $5(x + y) - 3(x - y) =$

- (A) $2x$
(B) $2x + 2y$
(C) $2x + 8y$
(D) $8x + 8y$

40. If $f(x) = 3x^2 + 4x - 5$, then $f(-2) =$

- (A) -49
(B) -1
(C) 9
(D) 23

41.

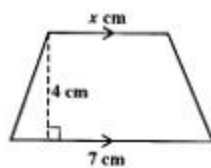

The area of the trapezium above is 22 cm^2 . What is the value of x ?

- (A) 3
(B) $3\frac{1}{7}$
(C) 4
(D) $5\frac{1}{2}$

42. If $2(x - 1) - 3x = 6$, then $x =$

- (A) -8
(B) -4
(C) 4
(D) 8

43.

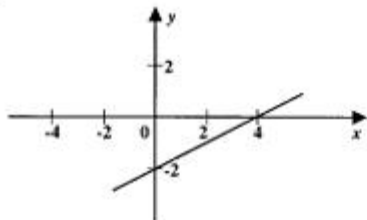

Which of the following relations is represented by the graph shown above?

- (A) $y + 2x - 4 = 0$
- (B) $y - 2x + 4 = 0$
- (C) $2y + x - 4 = 0$
- (D) $2y - x + 4 = 0$

44. Which of the following shapes is a square pyramid?

- (A)
- (B)
- (C)
- (D)

45. If $m = -2$ and $p = 3$, then $\frac{4p - m}{mp} =$

- (A) $-\frac{2}{3}$
- (B) $-\frac{5}{3}$
- (C) $\frac{5}{3}$
- (D) $\frac{7}{3}$

46. The exterior angles and the interior angles of a polygon are equal. How many sides does the polygon have?

- (A) 3
- (B) 4
- (C) 5
- (D) 6

47. What is the median of the sample 5, 5, 11, 9, 8, 5, 8?

- (A) 5
- (B) 6
- (C) 8
- (D) 9

48. $3m^2n^3 \times 4mn^2 =$

- (A) $7m^3n^5$
- (B) $12m^2n^5$
- (C) $12m^2n^6$
- (D) $7m^2n^5$

49. $\frac{3x+1}{2} - \frac{x+1}{4} =$

- (A) $\frac{5x+3}{4}$
- (B) $\frac{5x+1}{4}$
- (C) $\frac{7x+3}{4}$
- (D) $\frac{7x+1}{4}$

Item 50 below refers to the table which shows the distribution of the ages of 25 children.

Age	11	12	13	14	15	16
No. of children	6	3	5	4	4	3

50. What is the probability that a child chosen at random is AT LEAST 13 years old?

- (A) $\frac{4}{25}$
 (B) $\frac{5}{25}$
 (C) $\frac{11}{25}$
 (D) $\frac{16}{25}$

- 51.

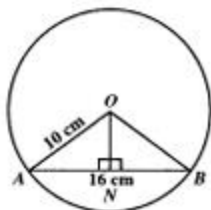

The diagram above shows a circle with centre O . A line ON is drawn perpendicular to AB . $OA = 10$ cm and $AB = 16$ cm, the length, in cm, of ON is

- (A) 5
 (B) 6
 (C) 8
 (D) 10

- 52.

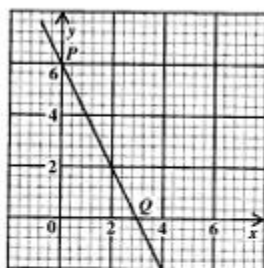

The gradient of the line PQ is

- (A) 2
 (B) $\frac{1}{2}$
 (C) -2
 (D) $-\frac{1}{2}$

- 53.

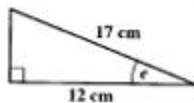

In the diagram above, which of the following is true?

- (A) $\sin e = \frac{12}{17}$
 (B) $\cos e = \frac{12}{17}$
 (C) $\sin e = \frac{17}{12}$
 (D) $\tan e = \frac{17}{12}$

54. If $\frac{1}{f} = \frac{1}{3} + \frac{1}{4}$, then $f =$

- (A) $\frac{7}{12}$
 (B) $\frac{17}{12}$
 (C) $\frac{12}{7}$
 (D) 7

55. A circular hole with diameter 6 cm is cut out of a circular piece of card with a diameter of 12 cm. The area of the remaining card, in cm^2 , is

(A) 6π
 (B) 27π
 (C) 36π
 (D) 108π

56. If $2x - 1 \leq 3x + 6$, then

(A) $x \geq -7$
 (B) $x \leq 7$
 (C) $x > -7$
 (D) $x < 7$

57. If $\frac{4}{x} + 4 = 16$, then $x =$

(A) $\frac{1}{16}$
 (B) $\frac{1}{3}$
 (C) 3
 (D) 48

58. $\frac{4x + 8}{2} =$

(A) $6x$
 (B) $2x + 4$
 (C) $4x + 4$
 (D) $2x + 8$

59. If the length, L , of a rectangle is 3 cm more than twice its width, W , then the relation between L and W is

(A) $L > 2W + 3$
 (B) $L = 2W + 3$
 (C) $L + 3 > 2W$
 (D) $2L + 3 = W$

- 60.

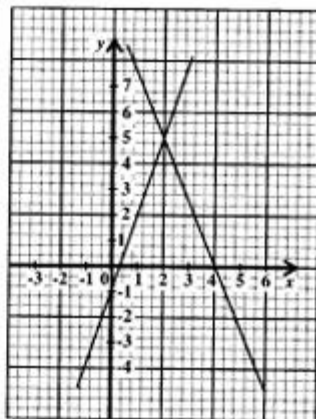

The diagram above shows the graphs of $3x - y = 1$ and $5x + 2y = 20$. Which ordered pair (x, y) satisfies both equations?

(A) (4, 0)
 (B) (0, 1)
 (C) (2, 5)
 (D) (5, 2)

TEST CODE **01234020**

FORM TP 2005015

JANUARY 2005

**CARIBBEAN EXAMINATIONS COUNCIL
SECONDARY EDUCATION CERTIFICATE
EXAMINATION
MATHEMATICS**

Paper 02 – General Proficiency

2 hours 40 minutes

04 JANUARY 2005 (a.m.)

INSTRUCTIONS TO CANDIDATES

1. Answer ALL questions in Section I, and any TWO from Section II.
2. Write your answers in the booklet provided.
3. All working must be shown clearly.
4. A list of formulae is provided on page 2 of this booklet.

Examination Materials

Electronic calculator (non-programmable)
Geometry set
Mathematical tables (provided)
Graph paper (provided)

DO NOT TURN THIS PAGE UNTIL YOU ARE TOLD TO DO SO

Copyright © 2003 Caribbean Examinations Council.
All rights reserved.

01234020/JANUARY/F 2005

LIST OF FORMULAE

Volume of a prism $V = Ah$ where A is the area of a cross-section and h is the perpendicular length.

Volume of a right pyramid $V = \frac{1}{3}Ah$ where A is the area of the base and h is the perpendicular height.

Circumference $C = 2\pi r$ where r is the radius of the circle.

Area of a circle $A = \pi r^2$ where r is the radius of the circle.

Area of trapezium $A = \frac{1}{2}(a + b)h$ where a and b are the lengths of the parallel sides and h is the perpendicular distance between the parallel sides.

Roots of quadratic equations If $ax^2 + bx + c = 0$,
then $x = \frac{-b \pm \sqrt{b^2 - 4ac}}{2a}$

Trigonometric ratios $\sin \theta = \frac{\text{opposite side}}{\text{hypotenuse}}$

$\cos \theta = \frac{\text{adjacent side}}{\text{hypotenuse}}$

$\tan \theta = \frac{\text{opposite side}}{\text{adjacent side}}$

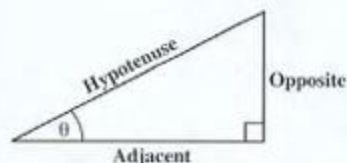

Area of triangle Area of $\Delta = \frac{1}{2}bh$ where b is the length of the base and h is the perpendicular height

Area of $\Delta ABC = \frac{1}{2}ab \sin C$

Area of $\Delta ABC = \sqrt{s(s-a)(s-b)(s-c)}$

where $s = \frac{a+b+c}{2}$

Sine rule $\frac{a}{\sin A} = \frac{b}{\sin B} = \frac{c}{\sin C}$

Cosine rule $a^2 = b^2 + c^2 - 2bc \cos A$

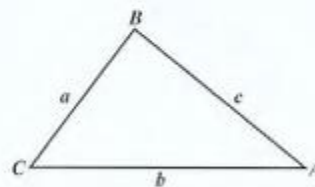
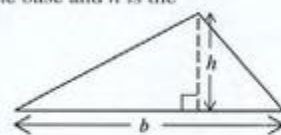

GO ON TO THE NEXT PAGE

SECTION I

Answer ALL the questions in this section.

All working must be clearly shown.

1. (a) Using a calculator, or otherwise, evaluate

$$\sqrt{\frac{13.2}{0.33}}$$

writing your answer correct to 3 decimal places.

(3 marks)

- (b) Kim has two telephones. One is cellular and the other is a land line. The rates for local calls are shown in the table below.

Rates	Type of Telephone	
	Cellular	Land Line
Monthly Rental Fee	\$0	\$45
Charge per minute on calls made	85 cents	15 cents

- (i) In one month, calls were made lasting for a total of 1 hour and 5 minutes. Show by calculations, that the cost for using the land line telephone was less than the cost for using the cellular telephone.
- (ii) For the month of March, the land line telephone was used, and the bill was \$54.60.

Calculate the total time, in minutes, for which the calls lasted. (8 marks)

Total 11 marks

2. (a) Given that $r = \frac{2p^2}{q-3}$,
- calculate the value of r when $p = 6$ and $q = 12$.
 - rearrange the formula to make q the subject. **(4 marks)**
- (b) Factorize completely
- $3g - 3t + 2mg - 2mt$
 - $3x^2 + 2x - 8$
 - $3x^2 - 27$ **(6 marks)**
- (c) Given that y varies inversely as x , use the values of x and y from the following table to calculate the value of a .

x	2	32
y	8	a

(2 marks)**Total 12 marks**

3. (a) 32 candidates took examinations at a CXC examinations centre.
- 11 took French (F)
 9 took Spanish (S)
 x took both French and Spanish
 18 took neither French nor Spanish
- (i) Copy and complete the following Venn diagram to represent the information.

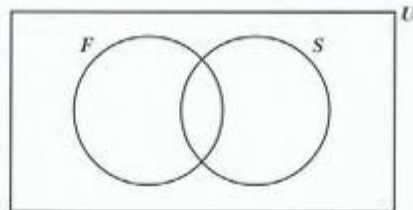

- Write an equation in x for the number of candidates in the universal set.
- Calculate the value of x .
- Shade the region $F' \cap S$. **(6 marks)**

- (b) The diagram below, **not drawn to scale**, shows the vertical cross section of a shed.

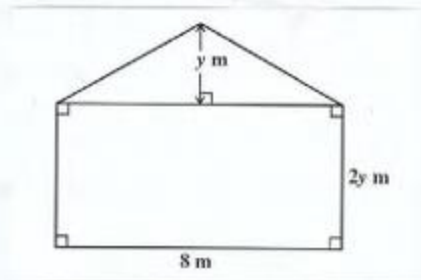

- (i) Write an expression in terms of y for the area of the figure shown.
 (ii) Calculate the value of y if the area of the figure is 28 m^2 .

(4 marks)

Total 10 marks

4. (a) Using a ruler, a pencil and a pair of compasses only, construct the *rectangle PQRS* in which $PQ = 8 \text{ cm}$ and $PS = 6 \text{ cm}$.

Measure and state the length of the diagonal, in centimetres.

(6 marks)

- (b) In the diagram below, **not drawn to scale**, WXY is a straight line with Y due east of W , and V due north of W .

Calculate

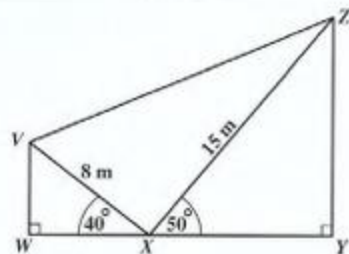

- (i) $\angle ZXV$
 (ii) $\angle ZVX$
 (iii) the length of VZ
 (iv) the bearing of V from X .

(6 marks)

Total 12 marks

5. (a) The functions f and g are such that
 $f(x) = \frac{2x + 5}{x - 4}$ and $g(x) = 2x - 3$.
- Calculate the value of
- (i) $g(4)$
 - (ii) $fg(2)$
 - (iii) $g^{-1}(7)$. (5 marks)
- (b) Write as a single fraction in its simplest form
 $\frac{3}{x} + \frac{4}{x + 1}$. (3 marks)
- (c) Calculate the value of
 $9^{1/2} \times 8^{2/3} \times 4^0$. (3 marks)

Total 11 marks

6. (a) A straight line is drawn through the points $A(1, 1)$ and $B(5, -2)$.
- (i) Calculate the gradient of the line AB .
 - (ii) Write down the gradient of any line that is perpendicular to AB .
 - (iii) Determine the equation of the line which passes through $D(3, 2)$ and is perpendicular to AB .
- Write your answer in the form: $y = mx + c$. (5 marks)
- (b) An answer sheet is provided for this question.
- On the answer sheet provided, draw on the given axes
- (i) a triangle with coordinates $(2, 1)$, $(3, 3)$ and $(4, 3)$. Label it A .
 - (ii) the image of triangle A after a reflection in the line $y = -1$. Label it B .
 - (iii) the image of triangle A after a translation by the vector $\begin{pmatrix} -4 \\ 2 \end{pmatrix}$. Label it C . (7 marks)

Total 12 marks

GO ON TO THE NEXT PAGE

7. The graph shown below is the cumulative frequency curve for the marks scored on a test by a class of 80 students.

Use the graph to estimate

- (i) the number of students who scored less than 23 marks **(2 marks)**
- (ii) the number of students who scored more than 17 marks **(2 marks)**
- (iii) the interquartile range of the marks scored **(3 marks)**
- (iv) the probability that a randomly chosen student from the class scored between 17 marks and 23 marks **(3 marks)**
- (v) the value of x if only 30 students from the class scored more than x marks. **(2 marks)**

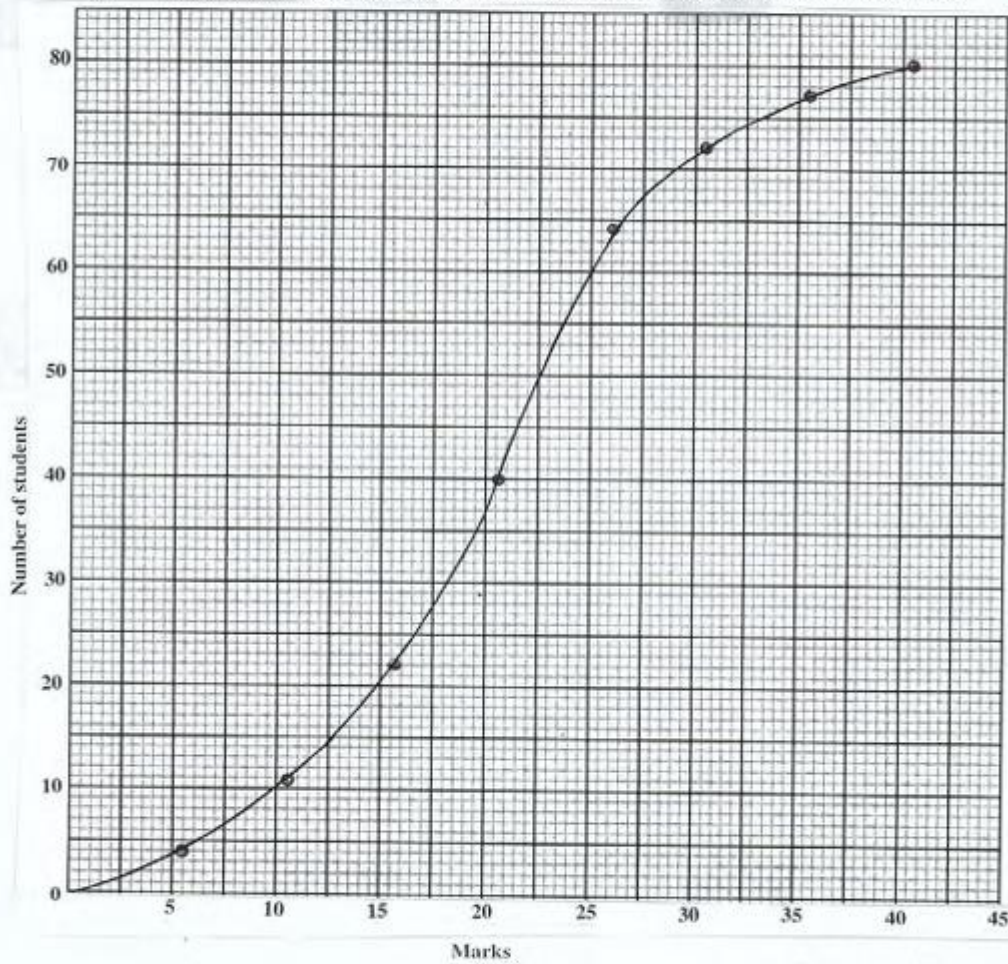

Total 12 marks

GO ON TO THE NEXT PAGE

8.

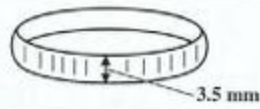

Diagram A

Diagram A, **not drawn to scale**, shows a link from a chain. Each link is a cylindrical ring of thickness 3.5 mm.

Diagram B shows the cross section of the ring. Each ring has internal diameter 14 mm and external diameter 16 mm.

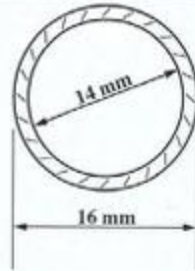

Diagram B

- (a) Taking $\pi = 3.14$, calculate the volume of metal in a single link of chain, writing your answer correct to 3 significant figures. **(4 marks)**

(b)

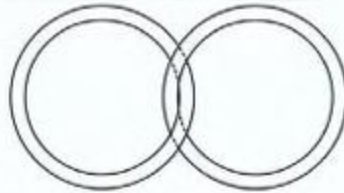

Diagram C

Two of the rings are linked as shown in Diagram C. Show that the length of the chain is $16 \text{ mm} + 14 \text{ mm}$. **(2 marks)**

- (c) Copy and complete the table below which shows the length of the chain formed when rings are linked in a straight line. **(4 marks)**

Number of rings	Length of chain (in mm)
1	16
2	30
3	44
6	—
—	170

Total 10 marks

GO ON TO THE NEXT PAGE

SECTION II

Answer TWO questions in this section.

RELATIONS, FUNCTIONS AND GRAPHS

9. (a) Solve the pair of simultaneous equations
- $$\begin{aligned}x^2 &= 4 - y \\ x &= y + 2\end{aligned}$$
- (5 marks)
- (b) By simplifying, show that
- $$(2x - 3)(2x + 3) - (x - 4)^2 = 3x^2 + 8x - 25$$
- (2 marks)
- (c) (i) Write $3x^2 + 8x - 25$ in the form $a(x + h)^2 + k$ where a , h and k are real numbers.
- (ii) Hence, or otherwise, determine the minimum value of $3x^2 + 8x - 25$.
- (5 marks)
- (d) Solve the equation
- $$3x^2 + 8x - 25 = 0$$
- giving your answers correct to one decimal place.
- (3 marks)

Total 15 marks

10. Miss James buys x calculators and y folders to sell at a school.

She must buy *at least* 5 calculators.

- (i) Write an inequality to represent this information. (1 mark)

The number of folders she buys must be *at least* twice the number of calculators.

- (ii) Write an inequality to represent this information. (2 marks)

A calculator costs \$20 and a folder costs \$5. Miss James must spend *no more* than \$300.

- (iii) Write an inequality to represent this information. (2 marks)

- (iv) a) Using a scale of 2 cm to represent 5 calculators on the x -axis and 2 cm to represent 10 folders on the y -axis, draw the graphs of the lines associated with the inequalities at (i), (ii) and (iii) above.

- b) Identify, by shading, the region which satisfies all three inequalities. (6 marks)

The profit on each calculator is \$6 and on each folder is \$2.

- (v) Write an expression in x and y for the total profit, P . (1 mark)

Using your graph

- (vi) Write down the coordinates of the vertices of the shaded region. (1 mark)

- (vii) Calculate the maximum profit. (2 marks)

Total 15 marks

GEOMETRY AND TRIGONOMETRY

11. (a) In the diagram below, **not drawn to scale**, RST is a horizontal straight line and UR represents a vertical pole.

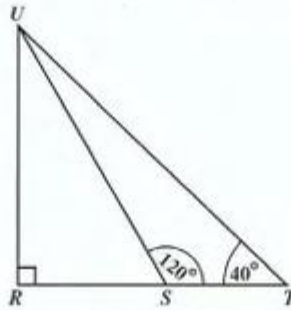

$ST = 15$ m, $\angle UST = 120^\circ$ and $\angle STU = 40^\circ$.

Calculate

- (i) the angle of elevation of U from S .
- (ii) the length of UT .
- (iii) the length of RU .

(7 marks)

- (b) The diagram below shows a circle, centre O . $LMNR$ is a tangent to the circle. $LSOP$, NOQ and MSQ are straight lines. $\angle SPN = 35^\circ$.

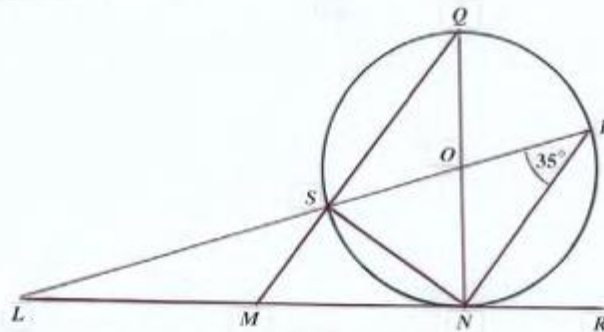

Calculate, giving reasons for each step of your answer,

- (i) $\angle SON$
- (ii) $\angle NMQ$
- (iii) $\angle PLN$
- (iv) $\angle SNM$

(8 marks)

Total 15 marks

GO ON TO THE NEXT PAGE

12. (a) For this question, take the radius of the earth to be 6370 km and $\pi = \frac{22}{7}$.
Two points, A and B , are located on the surface of the earth at $(45^\circ\text{N}, 40^\circ\text{E})$ and $(45^\circ\text{N}, 20^\circ\text{W})$ respectively.
- (i) Draw a diagram to represent the earth showing the equator, the line of O° longitude, and points A and B . **(4 marks)**
- (ii) Calculate the shortest distance between A and B measured along their common circle of latitude. **(4 marks)**
- (b) (i) Given that $y = 2 - \cos x$, copy and complete the table below.

x	0°	30°	60°	90°	120°	150°	180°
y		1.1	1.5		2.5		3

- (ii) Using a scale of 2 cm to represent 30° on the x -axis, and 1 cm to represent 0.2 on the y -axis, draw the graph of $y = 2 - \cos x$ for $0^\circ \leq x \leq 180^\circ$.
- (iii) Using the graph, or otherwise, determine the value of x for which
 $2 - \cos x = 1.8$. **(7 marks)**

Total 15 marks

VECTORS AND MATRICES

13. (a) The position vector of a point P, relative to an origin O, is given as $\vec{OP} = \begin{pmatrix} 1 \\ 1 \end{pmatrix}$.
 $m = \begin{pmatrix} 2 \\ 3 \end{pmatrix}$ and $n = \begin{pmatrix} 1 \\ -3 \end{pmatrix}$ are two vectors in the same plane as \vec{OP} .
 Given that $\vec{PQ} = m + 2n$

Calculate

- (i) \vec{PQ} , writing your answer in the form $\begin{pmatrix} x \\ y \end{pmatrix}$
 (ii) $|\vec{PQ}|$. (3 marks)
- (b) In the diagram below, **not drawn to scale**, M is the midpoint of CE.
 $\vec{OF} = \vec{a}$, $\vec{OC} = \vec{b}$ and $FE = 2 OF$.

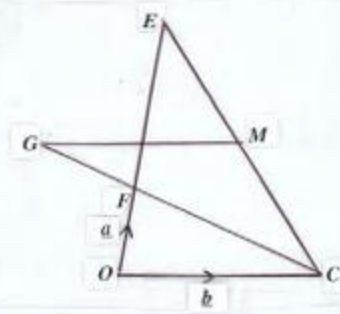

Express in terms of \vec{a} and \vec{b} in simplified form

- (i) \vec{CF} (2 marks)
 (ii) \vec{CE} (2 marks)
 (iii) \vec{CM} . (2 marks)

The point G is on CF produced so that $\vec{CG} = k\vec{CF}$ where k is a scalar.

- (iv) Express \vec{MG} in terms of \vec{a} , \vec{b} , and k. (3 marks)
 (v) Determine the value of k for which $\vec{MG} = \vec{CO}$. (3 marks)

Total 15 marks

14. (a) (i) Find the inverse of the matrix $M = \begin{bmatrix} 2 & 1 \\ -1 & 3 \end{bmatrix}$. (2 marks)
- (ii) Calculate the values of x and y for which $M \begin{bmatrix} x \\ y \end{bmatrix} = \begin{bmatrix} 12 \\ 1 \end{bmatrix}$. (4 marks)
- (b) Under a transformation T , represented by the matrix $\begin{bmatrix} p & q \\ r & s \end{bmatrix}$, the points $A(-4, 2)$ and $B(-2, 5)$ are mapped onto $A'(-2, 4)$ and $B'(-5, 2)$ respectively.
- Using a matrix method,
- (i) Determine the values of p , q , r and s . (6 marks)
- (ii) Calculate the coordinates of the point C' which is the image of $C(-2, 2)$ under T . (3 marks)

Total 15 marks

END OF TEST

TEST CODE **01234020**

JANUARY 2005

FORM TP 2005015

CARIBBEAN EXAMINATIONS COUNCIL

SECONDARY EDUCATION CERTIFICATE

EXAMINATION

MATHEMATICS

Paper 02 – General Proficiency

Answer Sheet for Question 6 (b)

Candidate Number

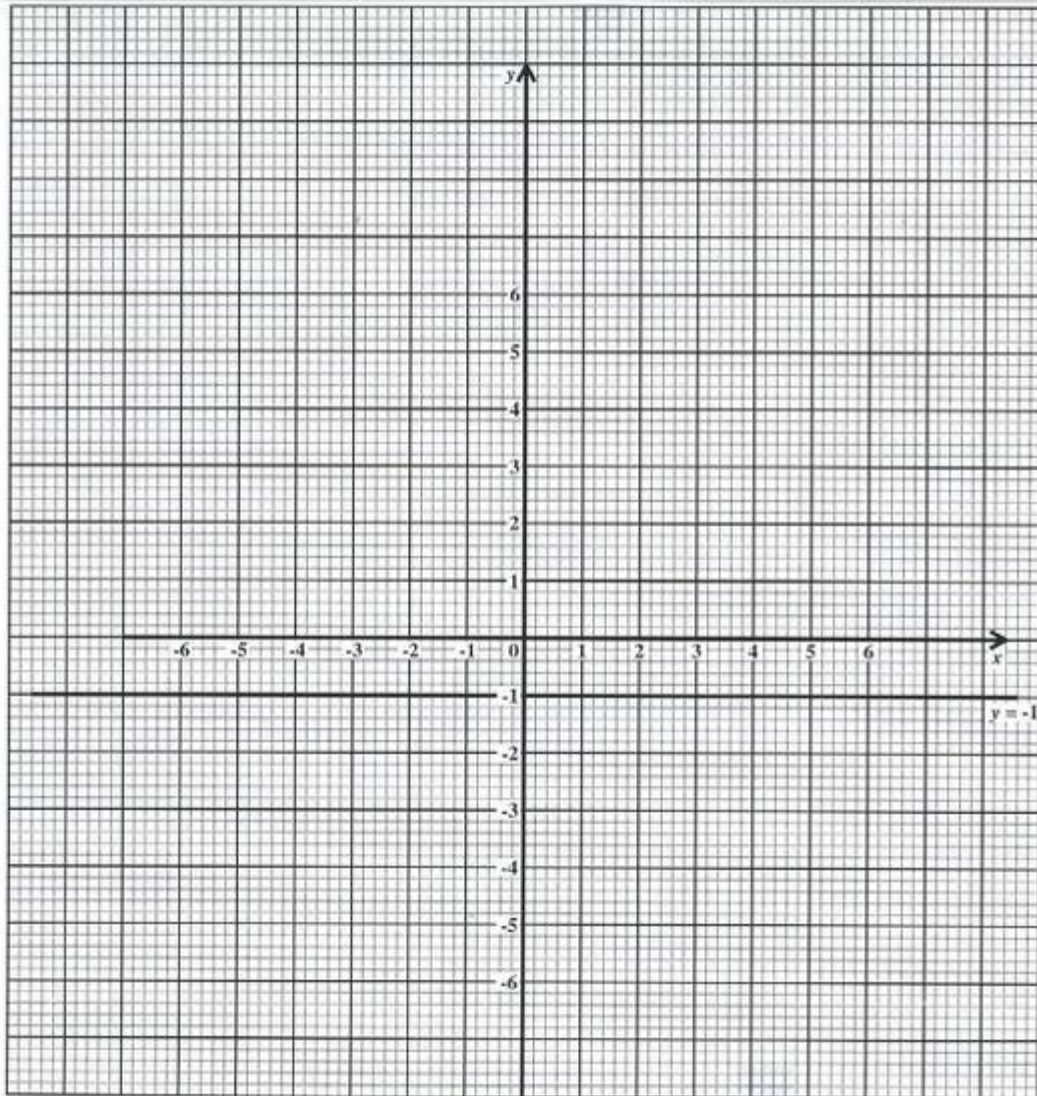

ATTACH THIS ANSWER SHEET TO YOUR BOOKLET

01234020/JANUARY/F 2005

FORM TP 2005106

TEST CODE **01234020**

MAY/JUNE 2005

**CARIBBEAN EXAMINATIONS COUNCIL
SECONDARY EDUCATION CERTIFICATE
EXAMINATION
MATHEMATICS**

Paper 02 – General Proficiency

2 hours 40 minutes

26 MAY 2005 (a.m.)

INSTRUCTIONS TO CANDIDATES

1. Answer ALL questions in Section I, and ANY TWO in Section II.
2. Write your answers in the booklet provided.
3. All working must be shown clearly.
4. A list of formulae is provided on page 2 of this booklet.

Examination Materials

Electronic calculator (non-programmable)
Geometry set
Mathematical tables (provided)
Graph paper (provided)

DO NOT TURN THIS PAGE UNTIL YOU ARE TOLD TO DO SO

Copyright © 2003 Caribbean Examinations Council.
All rights reserved.

01234020/F 2005

LIST OF FORMULAE

Volume of a prism	$V = Ah$ where A is the area of a cross-section and h is the perpendicular length.
Volume of a right pyramid	$V = \frac{1}{3}Ah$ where A is the area of the base and h is the perpendicular height.
Circumference	$C = 2\pi r$ where r is the radius of the circle.
Area of a circle	$A = \pi r^2$ where r is the radius of the circle.
Area of trapezium	$A = \frac{1}{2}(a + b)h$ where a and b are the lengths of the parallel sides and h is the perpendicular distance between the parallel sides.

Roots of quadratic equations If $ax^2 + bx + c = 0$,
then $x = \frac{-b \pm \sqrt{b^2 - 4ac}}{2a}$

Trigonometric ratios	$\sin \theta = \frac{\text{opposite side}}{\text{hypotenuse}}$
	$\cos \theta = \frac{\text{adjacent side}}{\text{hypotenuse}}$
	$\tan \theta = \frac{\text{opposite side}}{\text{adjacent side}}$

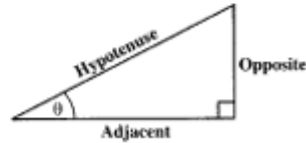

Area of triangle Area of $\Delta = \frac{1}{2}bh$ where b is the length of the base and h is the perpendicular height

$$\text{Area of } \Delta ABC = \frac{1}{2}ab \sin C$$

$$\text{Area of } \Delta ABC = \sqrt{s(s-a)(s-b)(s-c)}$$

$$\text{where } s = \frac{a+b+c}{2}$$

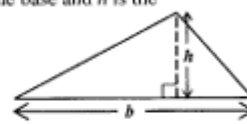

Sine rule $\frac{a}{\sin A} = \frac{b}{\sin B} = \frac{c}{\sin C}$

Cosine rule $a^2 = b^2 + c^2 - 2bc \cos A$

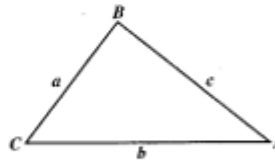

GO ON TO THE NEXT PAGE

SECTION I

Answer ALL the questions in this section.

All working must be clearly shown.

1. (a) Calculate the EXACT value of

$$4\frac{1}{5} - (1\frac{1}{9} \times 3)$$

(3 marks)

- (b) The table below shows Amanda's shopping bill. Some numbers were removed and replaced with letters

Items	Quantity	Unit Price (\$)	Total Cost (\$)
Stickers	12	0.49	5.88
T-shirts	3	12.50	A
CD's	2	B	33.90
Posters	C	6.20	31.00
Total			108.28
15% VAT (to the nearest cent)			D

- (i) Calculate the values of A, B, C and D. (5 marks)
- (ii) Amanda sold 6 of the 12 stickers which she had bought at 75 cents each, and the remaining stickers at 40 cents each.

Show, using calculations, whether Amanda made a profit or loss on buying and selling stickers. (3 marks)

Total 11 marks

2. (a) Factorise
- (i) $5a^2b + ab^2$ (2 marks)
- (ii) $-9k^2 - 1$ (2 marks)
- (iii) $2y^2 - 5y + 2$ (2 marks)
- (b) Expand and simplify
 $(2x + 5)(3x - 4)$ (2 marks)
- (c) Adam, Imran and Shakeel were playing a card game.
 Adam scored x points
 Imran scored 3 points fewer than Adam
 Shakeel scored twice as many points as Imran
 Together they scored 39 points.
- (i) Write down, in terms of x , an expression for the number of points scored by Shakeel. (2 marks)
- (ii) Write an equation which may be used to find the value of x . (2 marks)
- Total 12 marks**

3. (a)

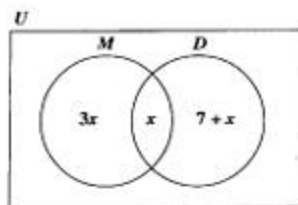

In the diagram shown above, the Universal set, (U), represents all the students in a class. The set M represents the students who take Music. The set D represents the students who take Drama. If 24 students take Music, calculate

- (i) the number of students who take BOTH Music and Drama
- (ii) the number of students who take Drama ONLY. (4 marks)
- (b) A straight line passes through the point $P(-3, 5)$ and has a gradient of $\frac{2}{3}$.
- (i) Write down the equation of this line in the form $y = mx + c$. (5 marks)
- (ii) Show that this line is parallel to the line $2x - 3y = 0$. (2 marks)

Total 11 marks

GO ON TO THE NEXT PAGE

4. The figures shown below, **not drawn to scale**, represent the cross sections of two circular pizzas. Both pizzas are equally thick and contain the same toppings.



- (a) Is a medium pizza twice as large as a small pizza?
Use calculations to support your answer. (5 marks)
- (b) A medium pizza is cut into 3 equal parts, and each part is sold for \$15.95. A small pizza is sold for \$12.95.
Which is the better buy?
Use calculations to support your answer. (5 marks)

Total 10 marks

5. (a) On graph paper, draw the x -axis and the y -axis. Using a scale of 1 cm to represent 1 unit on both axes, draw the triangle DEF with vertices $D(1, 1)$, $E(3, 1)$ and $F(1, 4)$. (3 marks)
- (b) (i) Draw the image of $\triangle DEF$ under reflection in the line $x = 4$. Name the image $\triangle D'E'F'$.
- (ii) Draw the image of $\triangle D'E'F'$ under the translation $\begin{bmatrix} 0 \\ -5 \end{bmatrix}$. Name the image $\triangle D''E''F''$.
- (iii) Name the type of transformation that maps $\triangle DEF$ onto $\triangle D''E''F''$. (5 marks)
- (c) A vertical stick of height 1.8 m casts a shadow of length 2 m on the horizontal as shown in the diagram below, **not drawn to scale**.

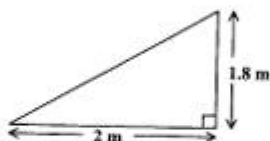

Calculate, to the NEAREST degree, the angle of elevation of the sun. (4 marks)

Total 12 marks

GO ON TO THE NEXT PAGE

6. (a) In the diagram shown below, $ABCDE$ is a pentagon. $\angle BAE = 108^\circ$, $\angle ABC = 90^\circ$, $\angle AED = 80^\circ$, $\angle ADC = 57^\circ$ and AE is parallel to CD .

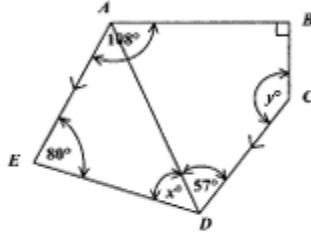

Calculate the size of the angle marked

- (i) x°
 (ii) y°

(4 marks)

Show all steps in your calculations and give reasons for your answers.

- (b) The functions f and g are defined by

$$f(x) = \frac{1}{2}x + 5, \quad g(x) = x^2.$$

Evaluate

- (i) $g(3) + g(-3)$
 (ii) $f^{-1}(6)$
 (iii) $fg(2)$

(8 marks)

Total 12 marks

7. The table below gives the distribution of heights of 400 female applicants for the Police Service.

Height (cm)	Number of Applicants	Cumulative Frequency
151 - 155	10	10
156 - 160	55	65
161 - 165	105	170
166 - 170	110	280
171 - 175	80	360
176 - 180	30	390
181 - 185	10	400

- (a) Using a horizontal scale of 2 cm to represent a height of 5 cm and a vertical scale of 2 cm to represent 50 applicants, draw a cumulative frequency curve of the heights.
Start your horizontal scale at 150 cm. (5 marks)
- (b) Use your graph to estimate
- (i) the number of applicants whose heights are less than 170 cm. (1 mark)
 - (ii) the median height of applicants. (2 marks)
 - (iii) the height that 25% of the applicants are less than (2 marks)
 - (iv) the probability that an applicant selected at random has a height that is no more than 162 cm. (2 marks)

Credit will be given for drawing appropriate lines on your graph to show how the estimates were obtained.

Total 12 marks

GO ON TO THE NEXT PAGE

8. (a) Study the number pattern in the table below and complete lines (i), (ii) and (iii) in your answer booklet.

	2^3	$(0 \times 3^2) + (3 \times 2) + 2$	8
	3^3	$(1 \times 4^2) + (3 \times 3) + 2$	27
	4^3	$(2 \times 5^2) + (3 \times 4) + 2$	64
	5^3	$(3 \times 6^2) + (3 \times 5) + 2$	125
(i)	6^3		
(ii)	10^3		
(iii)	n^3	$(n-2) \times ()^2 + (3 \times) + 2$	n^3

(7 marks)

- (b) Show that

$$(a-b)^2(a+b) + ab(a+b) = a^3 + b^3.$$

(3 marks)

Total 10 marks

SECTION II

Answer TWO questions in this section.

ALGEBRA AND RELATIONS, FUNCTIONS AND GRAPHS

9. (a) Write $5x^2 + 2x - 7$ in the form $a(x+b)^2 + c$, where a , b , and c are real numbers. (4 marks)
- (b) Hence, or otherwise, determine
- the minimum value of the function $y = 5x^2 + 2x - 7$
 - the value of x at which the minimum occurs (3 marks)
- (c) Find the values of x for which $5x^2 + 2x - 7 = 0$. (3 marks)
- (d) Sketch the graph of $y = 5x^2 + 2x - 7$, clearly showing
- the coordinates of the minimum point
 - the value of the y -intercept
 - the points where the graph cuts the x -axis. (5 marks)

Total 15 marks

10. (a) The speed-time graph below shows the movement of a cyclist.

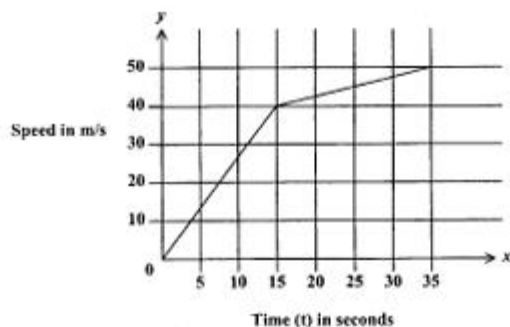

Using the graph, calculate

- the acceleration of the cyclist during the first 15 seconds
- the distance traveled by the cyclist between the period $t = 15$ and $t = 35$ seconds. (6 marks)

- (b) The graph below represents the 5-hour journey of an athlete.

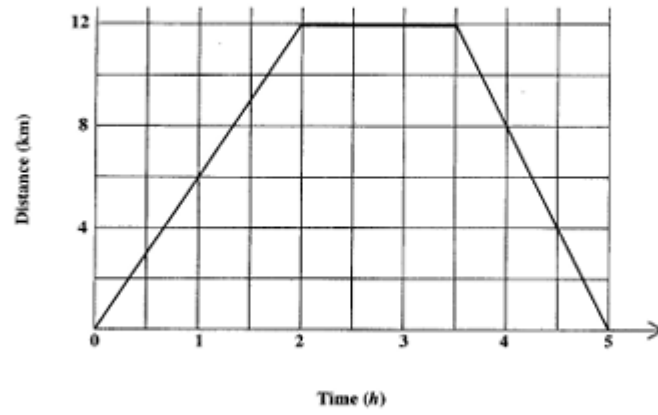

- (i) What was the average speed during the first 2 hours?
- (ii) What did the athlete do between 2 and 3 hours after the start of the journey?
- (iii) What was the average speed on the return journey? **(5 marks)**

- (c) The diagram below shows a triangular region bounded by the lines $y = \frac{1}{6}x + 5$, $y = \frac{5}{8}x + 5$ and the line HK .

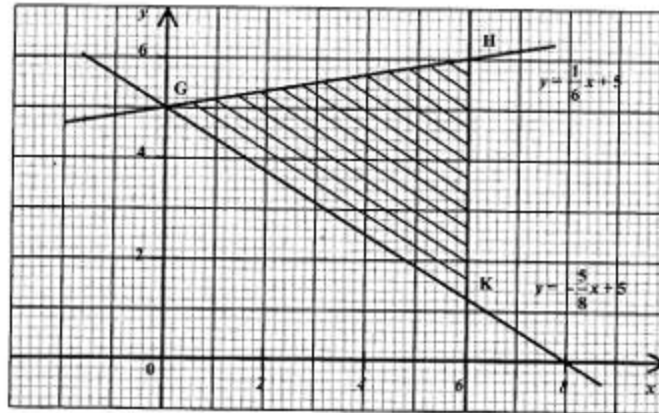

- (i) Write the equation of the line HK . (1 mark)
- (ii) Write the set of **three inequalities** which define the shaded region GHK . (3 marks)

Total 15 marks

GEOMETRY AND TRIGONOMETRY

11. (a)

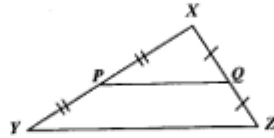

In the diagram above, **not drawn to scale**, P and Q are midpoints of the sides XY and XZ of triangle XYZ . Given that $XP = 7.5$ cm, $XQ = 4.5$ cm and the area of triangle $XPQ = 13.5$ cm², calculate

- (i) the size of angle PXQ , expressing your answer correct to the nearest degree.
- (ii) the area of triangle XYZ . (6 marks)

(b)

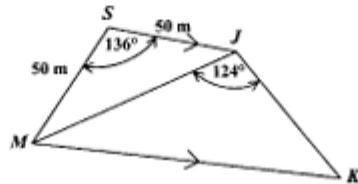

The figure $SJKM$ above, **not drawn to scale**, is a trapezium with SJ parallel to MK , angle $MJK = 124^\circ$, angle $MSJ = 136^\circ$, and $SM = SJ = 50$ metres.

- (i) Calculate the size of
 - a) angle SJM
 - b) angle JKM . (3 marks)
- (ii) Calculate, expressing your answer correct to ONE decimal place, the length of
 - a) MJ
 - b) JK . (6 marks)

Total 15 marks

GO ON TO THE NEXT PAGE

12. In this question, assume the earth to be a sphere of radius 6 400 km and use $\pi = 3.14$.

The latitudes and longitudes of Antigua and of Belize are given in the table below.

Country	Latitude	Longitude
Antigua	17°N	62°W
Belize	17°N	88°W

- (a) Draw a sketch of the earth showing the location of Antigua and of Belize, their associated circles of latitude and longitude, the equator, and the Greenwich Meridian. (6 marks)
- (b) Calculate the shortest distance between Antigua and Belize measured along their common circle of latitude. (5 marks)
- (c) A town, Bahia Blanka, situated in South America, lies on a meridian 62°W and has a latitude of 38°S. Calculate the shortest distance between Antigua and Bahia Blanka measured along the common circle of longitude. (4 marks)

Total 15 marks

GO ON TO THE NEXT PAGE

VECTORS AND MATRICES

13.

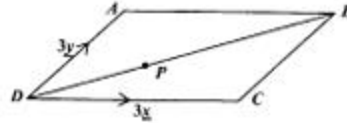

In the figure above, **not drawn to scale**, $ABCD$ is a parallelogram such that $\vec{DC} = 3\vec{x}$ and $\vec{DA} = 3\vec{y}$. The point P is on DB such that $DP : PB = 1 : 2$.

- (a) Express in terms of \vec{x} and \vec{y} :
- \vec{AB}
 - \vec{BD}
 - \vec{DP} (5 marks)
- (b) Show that $\vec{AP} = \vec{x} - 2\vec{y}$. (2 marks)
- (c) Given that E is the mid-point of DC , prove that A , P and E are collinear. (4 marks)
- (d) Given that $x = \begin{bmatrix} 2 \\ 0 \end{bmatrix}$ and $y = \begin{bmatrix} 1 \\ 1 \end{bmatrix}$, use a vector method to prove that triangle AED is isosceles. (4 marks)

Total 15 marks

14. (a) Given that $M = \begin{pmatrix} 2 & 5 \\ 7 & 15 \end{pmatrix}$.

- (i) Show that M is a non-singular matrix.
- (ii) Write down the inverse of M .
- (iii) Write down the 2x2 matrix which is equal to the product $M \times M^{-1}$.
- (iv) Pre-multiply both sides of the following matrix equation by M^{-1} .

$$\begin{pmatrix} 2 & 5 \\ 7 & 15 \end{pmatrix} \begin{pmatrix} x \\ y \end{pmatrix} = \begin{pmatrix} -3 \\ 17 \end{pmatrix}$$

Hence solve for x and y .

(7 marks)

- (b) (i) Write down the 2x2 matrix, R , which represents a reflection in the y -axis.
- (ii) Write down the 2x2 matrix, N , which represents a clockwise rotation of 180° about the origin.
- (iii) Write down the 2x1 matrix, T which represents a translation of -3 units parallel to the x -axis and 5 units parallel to the y -axis.
- (iv) The point $P(6, 11)$ undergoes the following combined transformations such that

$RN(P)$ maps P onto P'

$NT(P)$ maps P onto P''

Determine the coordinates of P' and P'' .

(8 marks)

Total 15 marks

END OF TEST

FORM TP 2005104

TEST CODE **01134020**

MAY/JUNE 2005

**CARIBBEAN EXAMINATIONS COUNCIL
SECONDARY EDUCATION CERTIFICATE
EXAMINATION
MATHEMATICS**

Paper 02 – Basic Proficiency

2 hours 40 minutes

26 MAY 2005 (a.m.)



INSTRUCTIONS TO CANDIDATES

1. Answer **ALL** questions.
2. Write your answers in the booklet provided.
3. All working must be shown clearly.
4. A list of formulae is provided on page 2 of this booklet.

Examination Materials

Electronic calculator (non-programmable)
Geometry set
Mathematical tables (provided)
Graph paper (provided)

DO NOT TURN THIS PAGE UNTIL YOU ARE TOLD TO DO SO

Copyright © 2003 Caribbean Examinations Council.
All rights reserved.

01134020/F 2005

LIST OF FORMULAE

Volume of a prism $V = Ah$ where A is the area of a cross-section and h is the perpendicular length.

Volume of a right pyramid $V = \frac{1}{3}Ah$ where A is the area of the base and h is the perpendicular height.

Circumference $C = 2\pi r$ where r is the radius of the circle.

Area of a circle $A = \pi r^2$ where r is the radius of the circle.

Area of trapezium $A = \frac{1}{2}(a + b)h$ where a and b are the lengths of the parallel sides and h is the perpendicular distance between the parallel sides.

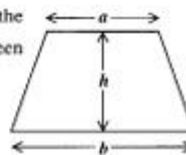

Roots of quadratic equations If $ax^2 + bx + c = 0$,
then $x = \frac{-b \pm \sqrt{b^2 - 4ac}}{2a}$

Trigonometric ratios $\sin \theta = \frac{\text{opposite side}}{\text{hypotenuse}}$

$$\cos \theta = \frac{\text{adjacent side}}{\text{hypotenuse}}$$

$$\tan \theta = \frac{\text{opposite side}}{\text{adjacent side}}$$

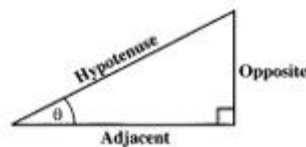

Area of triangle Area of $\Delta = \frac{1}{2}bh$ where b is the length of the base and h is the perpendicular height

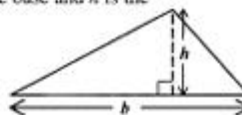

Area of sector Area = $\frac{\alpha}{360} \times \pi r^2$

where α is measured in degrees.

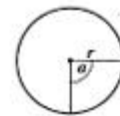

Arc of length Arc length = $\frac{\alpha}{360} \times 2\pi r$

GO ON TO THE NEXT PAGE

SECTION I

All working must be clearly shown.

1. (a) Calculate the value of $\frac{1.092}{24}$, expressing your answer
- (i) exactly
- (ii) in standard form (3 marks)
- (b) In a certain school, 58% of the students are girls. If there are 406 girls in the school, calculate the total number of students in the school. (2 marks)
- (c) The table below shows the points scored by two teams in a spelling competition.

	First Round	Second Round
Team A	96	72
Team B	58	<input type="text"/>

- (i) In the second round, the ratio of points scored by Team A to Team B was 4:3. How many points did Team B score in the second round?
- (ii) What is the LEAST number of points Team B should have scored in the second round so that the total score of Team B would be larger than the total score of Team A? (5 marks)
- Total 10 marks**
2. (a) How much interest is earned when \$800 is invested at 10% per annum compound interest for two years? (3 marks)
- (b) Mr James works a basic week of 40 hours at a rate of \$16 an hour. His overtime rate is \$4 per hour MORE than his basic rate.
- Calculate
- (i) his total wage for a basic week
- (ii) his wage for a week in which he worked 47 hours
- (iii) the number of hours he worked during one week if he was paid a wage of \$860. (7 marks)

Total 10 marks

3. (a) A man who has a wife and two children earns \$32 000 a year. The annual tax-free allowances are shown in Table 1.

Table 1

	Allowance
Adult	\$900 each
Child	\$400 each
Housing	\$2 500 per family

Calculate

- (i) his TOTAL annual tax-free allowances
 (ii) his annual taxable income

Table 2 shows the taxes that are due annually.

Table 2

Taxable Income	Taxes Due
First \$20 000	\$1 200
Remainder	30% of the remainder

- (iii) Calculate the taxes that he should pay annually. **(5 marks)**
- (b) A car is advertised for sale at \$8 400. A discount of 12% is given if it is bought for cash. It can also be bought on hire purchase by paying a deposit of \$2 940 followed by 24 monthly payments of \$230 each. Calculate
- (i) the cash price
 (ii) the hire purchase price
 (iii) the amount saved by buying the car for cash rather than on hire purchase.

(5 marks)

Total 10 marks

4. (a) Solve the simultaneous equations.

$$4x + 3y = 26$$

$$2x - y = 8$$

(5 marks)

- (b) In the figure below, **not drawn to scale**, ABC is an isosceles triangle with $\angle CAB = p^\circ$ and $\angle ABC = (p + 3)^\circ$.

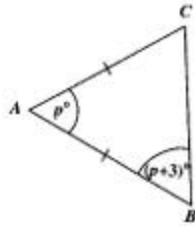

- (i) Write an expression in terms of p for the value of the angle at C .

- (ii) Determine the size of EACH angle in the triangle.

(5 marks)

Total 10 marks

5. (a) Given that $x = 2$ and $y = -3$, calculate the value of xy^2 .

(2 marks)

- (b) Simplify

$$\frac{3x}{12} - \frac{x + 2}{8}$$

(4 marks)

- (c) (i) Solve the inequality:

$$3x - 5 - 5x < 7, \text{ where } x \text{ is a real number.}$$

- (ii) Copy the number line below and draw on it the solution set for the inequality in (c) (i) above.

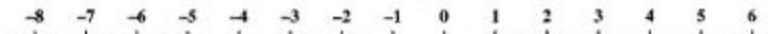

(4 marks)

Total 10 marks

GO ON TO THE NEXT PAGE

6. An answer sheet is provided for this question.

- (a) The answer sheet shows the line, l , which passes through the points $Q (0, -1)$ and $R (3, 2)$.

- (i) Determine the gradient of the line, l .
 (ii) Write down the equation of the line, l . **(4 marks)**

- (b) The table below shows three of the values of $f(x) = x^2 - 4x + 3$ for values of x from 0 to 4.

x	0	1	2	3	4
$f(x)$	3		-1	0	

- (i) Copy the table and insert the missing values of $f(x)$.
 (ii) Using the same axes and the same answer sheet as (a) above, draw the graph of $f(x) = x^2 - 4x + 3$.
 (iii) Using the graphs, write down the coordinates of the points of intersection of the line, l , and the graph of $f(x)$. **(6 marks)**

Total 10 marks

7. (a) A bus left Town X at 07:30 a.m. to travel to Town Y, 32 km away. The bus arrived at Town Y at 08:10 a.m.

- (i) How long did the bus take to travel from Town X to Town Y?
 (ii) Calculate the average speed, in km h^{-1} , of the bus for the journey. **(4 marks)**

GO ON TO THE NEXT PAGE

- (b) The diagram below, **not drawn to scale**, shows a container in the shape of a rectangular prism.

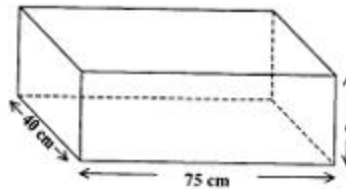

The base of the container has a length of 75 cm and a width of 40 cm.

- (i) Calculate the area, in cm^2 , of the base of the container

Water is poured into the container, reaching a height of 15 cm.

- (ii) Calculate, in cm^3 , the volume of water in the container.
- (iii) If the container holds 84 litres when full, calculate the height, h , in cm, of the water when the container is full. **(6 marks)**

Total 10 marks

8. (a) (i) Using only a pencil, a ruler and a pair of compasses, construct rectangle $KLMN$, in which $LM = 7$ cm, angle LMN is 90° and $MN = 6.5$ cm.
- (ii) Measure and write down the length of the diagonal LN , in cm. **(5 marks)**
- (b) In the figure below, **not drawn to scale**, triangles BCD and ACE are right-angled triangles. ACE is an enlargement of BCD with centre C . $BC = 12$ cm, $CD = 16$ cm and $AE = 60$ cm.

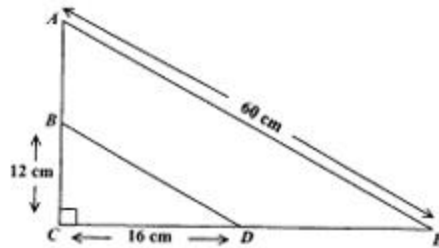

- (i) Calculate, in cm, the length of the side BD .
- (ii) Determine the scale factor of the enlargement. **(5 marks)**

Total 10 marks

GO ON TO THE NEXT PAGE

9. (a) The point $M(-2, 7)$ is translated by the column vector $\begin{pmatrix} x \\ y \end{pmatrix}$ to give the image $M'(8, 23)$. Calculate the values of x and y . **(2 marks)**
- (b) The diagram below, **not drawn to scale**, shows a vertical flagpole, FG , which is kept in place by two ropes, GM and GN , fixed at M and N on level horizontal ground. MFN is a straight line.

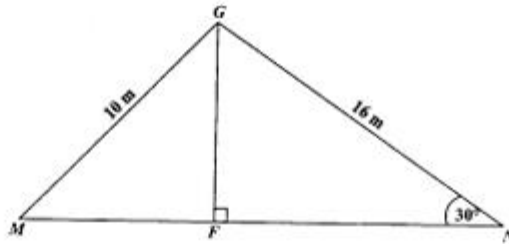

The length of GM is 10 m and the length of GN is 16 m. The angle of elevation of G from N is 30° .

Calculate correct to the nearest whole number

- (i) the length, in metres, of the flagpole **(4 marks)**
- (ii) the angle of elevation of G from M . **(4 marks)**

Total 10 marks

10. The bar chart below shows the shoe sizes of a group of 50 children.

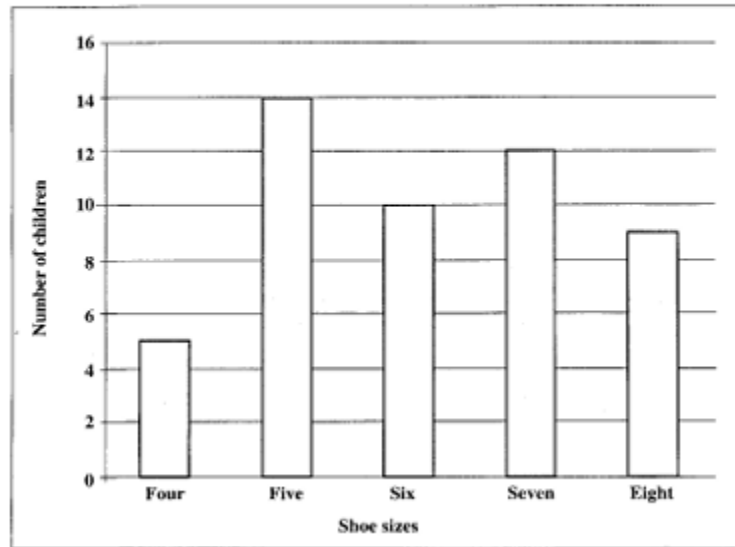

- (a) How many children wear a size 7 shoe? (1 mark)
- (b) How many children wear a shoe size smaller than size 7? (1 mark)
- (c) Which shoe size is the **modal** shoe size? (1 mark)
- (d) Which shoe size is the **median** shoe size? (2 marks)
- (e) What is the probability that a child selected at random wears:
- (i) a shoe size of 5? (3 marks)
- (ii) a shoe size larger than 6? (3 marks)
- (f) Which of these two averages, the mode and the median, would be of greater interest to the owner of a shoe shop who wishes to stock up on children's shoes? Give a reason for your answer. (2 marks)

Total 10 marks

END OF TEST

TEST CODE **01134020**

FORM TP 2005104

MAY/JUNE 2005

CARIBBEAN EXAMINATIONS COUNCIL

**SECONDARY EDUCATION CERTIFICATE
EXAMINATION**

MATHEMATICS

Paper 02 – Basic Proficiency

Answer Sheet for Question 6

Candidate Number

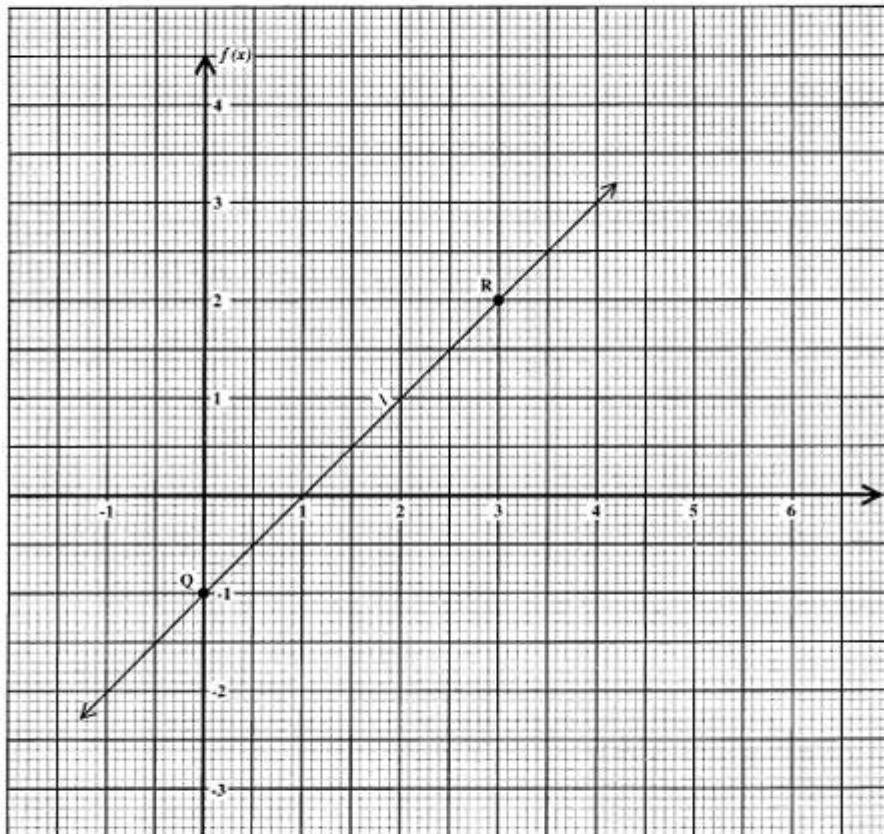

ATTACH THIS ANSWER SHEET TO YOUR ANSWER BOOKLET

FORM TP 2006017

TEST CODE **01234020**

JANUARY 2006

**CARIBBEAN EXAMINATIONS COUNCIL
SECONDARY EDUCATION CERTIFICATE
EXAMINATION
MATHEMATICS**

Paper 02 – General Proficiency

2 hours 40 minutes

04 JANUARY 2006 (a.m.)

INSTRUCTIONS TO CANDIDATES

1. Answer ALL questions in Section I, and ANY TWO in Section II.
2. Write your answers in the booklet provided.
3. All working must be shown clearly.
4. A list of formulae is provided on page 2 of this booklet.

Examination Materials

Electronic calculator (non-programmable)

Geometry set

Mathematical tables (provided)

Graph paper (provided)

DO NOT TURN THIS PAGE UNTIL YOU ARE TOLD TO DO SO

Copyright © 2004 Caribbean Examinations Council®.

All rights reserved.

01234020/JANUARY/F 2006

LIST OF FORMULAE

Volume of a prism	$V = Ah$, where A is the area of a cross-section and h is the perpendicular length.
Volume of cylinder	$V = \pi r^2 h$, where r is the radius of the base and h is the perpendicular height.
Volume of a right pyramid	$V = \frac{1}{3}Ah$, where A is the area of the base and h is the perpendicular height.
Circumference	$C = 2\pi r$, where r is the radius of the circle.
Area of a circle	$A = \pi r^2$, where r is the radius of the circle.
Area of trapezium	$A = \frac{1}{2}(a + b)h$, where a and b are the lengths of the parallel sides and h is the perpendicular distance between the parallel sides.

Roots of quadratic equations If $ax^2 + bx + c = 0$,
then $x = \frac{-b \pm \sqrt{b^2 - 4ac}}{2a}$

Trigonometric ratios

$$\sin \theta = \frac{\text{opposite side}}{\text{hypotenuse}}$$

$$\cos \theta = \frac{\text{adjacent side}}{\text{hypotenuse}}$$

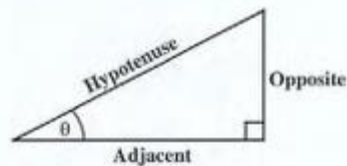
$$\tan \theta = \frac{\text{opposite side}}{\text{adjacent side}}$$

Area of triangle Area of $\Delta = \frac{1}{2}bh$, where b is the length of the base and h is the perpendicular height

$$\text{Area of } \Delta ABC = \frac{1}{2}ab \sin C$$

$$\text{Area of } \Delta ABC = \sqrt{s(s-a)(s-b)(s-c)}$$

$$\text{where } s = \frac{a+b+c}{2}$$

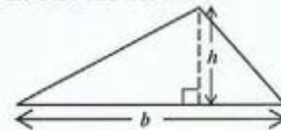

Sine rule $\frac{a}{\sin A} = \frac{b}{\sin B} = \frac{c}{\sin C}$

Cosine rule $a^2 = b^2 + c^2 - 2bc \cos A$

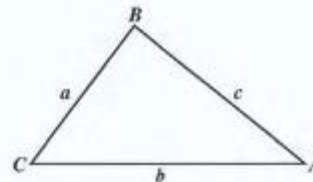

GO ON TO THE NEXT PAGE

SECTION I

Answer ALL the questions in this section.

All working must be clearly shown.

1. (a) Using a calculator, or otherwise, calculate
- (i) the exact value of $\frac{2\frac{1}{4} \times \frac{4}{5}}{\frac{3}{5} - \frac{1}{2}}$ (4 marks)
- (ii) correct to 3 significant figures, the value of $18.75 - (2.11)^2$. (3 marks)
- (b) A loan of \$12 000 was borrowed from a bank at 14% per annum.
Calculate
- (i) the interest on the loan at the end of the first year (2 marks)
- (ii) the total amount owing at the end of the first year. (1 mark)
- A repayment of \$7 800 was made at the start of the second year.
Calculate
- (iii) the amount still outstanding at the start of the second year (1 mark)
- (iv) the interest on the outstanding amount at the end of the second year. (1 mark)
- Total 12 marks**

2. (a) Given that $m = -2$ and $n = 4$, calculate the value of $(2m + n)(2m - n)$. (2 marks)
- (b) Solve the simultaneous equations
- $$\begin{aligned} 5x + 6y &= 37 \\ 2x - 3y &= 4. \end{aligned}$$
- (4 marks)
- (c) Factorise completely
- (i) $4x^2 - 25$ (2 marks)
- (ii) $6p - 9ps + 4q - 6qs$ (2 marks)
- (iii) $3x^2 + 4x - 4$. (2 marks)

Total 12 marks

3. (a) Given the formula $s = \frac{1}{2}(u + v)t$, express u in terms of v , s , and t . (3 marks)
- (b) On a certain day, 300 customers visited a bakery that sells bread and cakes.
- 70 customers bought cakes only
 80 customers bought neither bread nor cakes
 $2x$ customers bought bread only
 x customers bought both bread and cakes

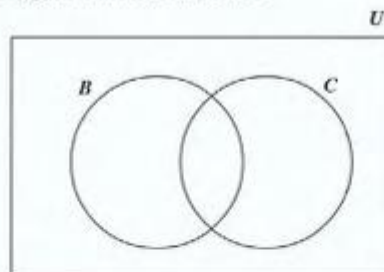

- (i) U represents the set of customers visiting the bakery on that day, B represents the set of customers who bought bread, and C represents the set of customers who bought cake. Copy and complete the Venn diagram to illustrate the information. (3 marks)
- (ii) Write an expression in x to represent the TOTAL number of customers who visited the bakery on that day. (2 marks)
- (iii) Calculate the number of customers who bought bread ONLY. (3 marks)

Total 11 marks

GO ON TO THE NEXT PAGE

4. (a) The equation of the line l is $y = 4x + 5$.
- (i) State the gradient of any line that is parallel to l . (1 mark)
- (ii) Determine the equation of the line parallel to l that passes through the point $(2, -6)$. (3 marks)
- (b) An answer sheet is provided for this question.

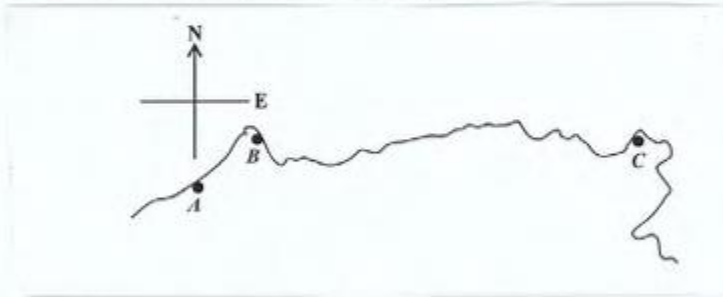

The diagram above shows the positions of three cities, A , B and C , on the north coast of Africa. The scale of the map is $1 : 20\,000\,000$.

Use your answer sheet when answering the following questions. Show all lines and angles used in your calculations.

- (i) Measure and state, in centimetres, the length of the line segment, BC . (2 marks)
- (ii) Hence, calculate in kilometres, the actual **shortest** distance from City B to City C . (2 marks)
- (iii) Using a protractor, determine the bearing of B from A . (4 marks)

Total 12 marks

5. The curved surface area of a cylinder = $2\pi rh$, where r is the radius and h is the height, and the surface area of a sphere is $4\pi r^2$.

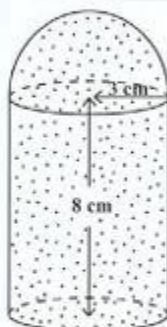

The diagram above, **not drawn to scale**, shows a **solid** glass paperweight which consists of a hemisphere mounted on a cylinder.

The radius of the hemisphere is 3 cm, the radius of the cylinder is 3 cm and its height is 8 cm.

- (a) Calculate, using $\pi = 3.14$,
- the curved surface area of the cylinder (2 marks)
 - the surface area of the hemisphere (2 marks)
 - the TOTAL surface area of the **solid** paperweight. (2 marks)
- (b) Using a ruler, a pencil, and a pair of compasses, construct the parallelogram $KLMN$, in which $KL = 8$ cm, $KN = 6$ cm, and $\angle LKN = 60^\circ$. (5 marks)

Total 11 marks

6. An answer sheet is provided for this question.

The diagram below shows quadrilateral $PQRS$, and its image, quadrilateral $P'Q'R'S'$, after it has been rotated.

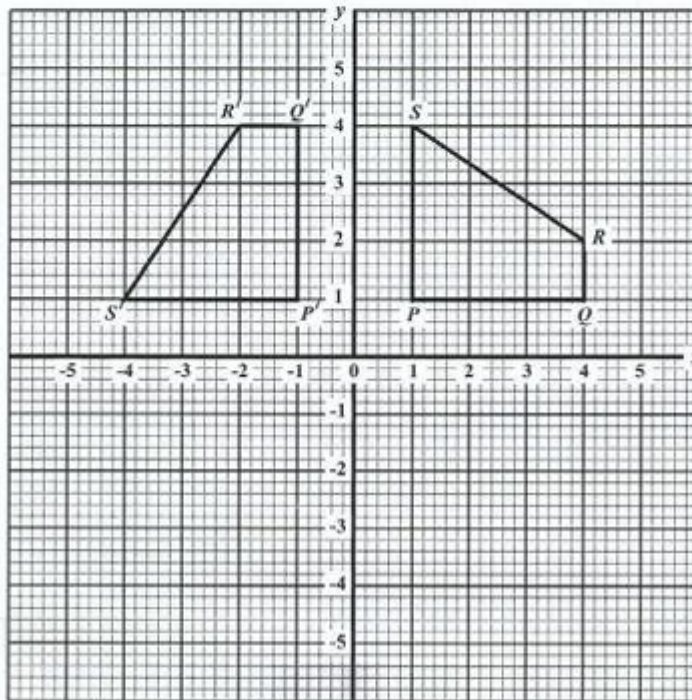

- (a) State the coordinates of the points R' and S' . (2 marks)
- (b) Describe the rotation completely. (3 marks)
- (c) On the answer sheet provided, draw and label quadrilateral $P''Q''R''S''$ which is the image of $P'Q'R'S'$ after it has been reflected in the x -axis. (3 marks)
- (d) Describe completely, the single transformation that maps quadrilateral $PQRS$ onto $P''Q''R''S''$. (2 marks)

Total 10 marks

7. The data below are the lengths, to the nearest centimetre, of the right foot of the 25 students in a class.

14	18	20	22	24
15	18	20	22	25
16	18	21	22	25
16	19	22	23	26
17	19	22	23	27

- (a) Copy and complete the following grouped frequency table for the data above.

Length of Right Foot (cm)	Frequency
14 – 16	4
17 – 19	—
20 – 22	8
—	5
26 – 28	2

(2 marks)

- (b) State the lower boundary of the class interval 14 – 16. (1 mark)
- (c) State the width of the class interval 20 – 22. (1 mark)
- (d) A student's right foot measured 16.8 cm. State the class interval in which this length would lie. (1 mark)
- (e) A student was chosen at random from the group, and the length of his right foot was measured. Calculate the probability that the length was GREATER THAN or EQUAL to 20 cm. (2 marks)
- (f) State the modal length of a student's right foot. (1 mark)
- (g) Calculate an estimate of the mean length of a student's right foot using the midpoints of the class intervals in (a) above. (3 marks)

Total 11 marks

8. The path of a ball thrown in the air is given by the equation $h = 20t - 5t^2$ where h is the vertical distance above the ground (in metres) and t is the time (in seconds) after the ball was thrown.

The table below shows some values of t and the corresponding values of h , correct to 1 decimal place.

t	0	0.5	1	1.5	2	2.5	3	3.5	4
h	0.0	8.8	15	18.8		18.8		8.8	0.0

- (a) Copy and complete the table of values. (2 marks)
- (b) Draw the graph of $h = 20t - 5t^2$ for $0 \leq t \leq 4$. You may proceed as follows:
- Using a scale of 2 cm to represent 0.5 seconds, draw the horizontal t -axis for $0 \leq t \leq 4$. (1 mark)
 - Using a scale of 1 cm to represent 1 metre, draw the vertical h -axis for $0.0 \leq h \leq 21.0$. (1 mark)
 - Plot the points from your table of values on the axes drawn. (2 marks)
 - Join the points with a smooth curve. (1 mark)
- (c) Using your graph, calculate estimates of
- the GREATEST height above the ground reached by the ball (1 mark)
 - the number of seconds for which the ball was MORE than 12 metres above the ground (2 marks)
 - the interval of time during which the ball was moving upwards. (1 mark)

Total 11 marks

SECTION II

Answer TWO questions in this section

ALGEBRA AND RELATIONS, FUNCTIONS AND GRAPHS

9. (a) Solve the pair of simultaneous equations

$$2x + y = 7$$

$$x^2 - xy = 6.$$

(6 marks)

- (b) Express
- $4x^2 - 12x - 3$
- in the form
- $a(x + h)^2 + k$
- , where
- a
- ,
- h
- and
- k
- are real numbers.
-
- (3 marks)

- (c) Using your answer from (b) above, or otherwise, calculate

(i) the minimum value of $4x^2 - 12x - 3$ (1 mark)

(ii) the value of x for which the minimum occurs (1 mark)

(iii) the values of x for which $4x^2 - 12x - 3 = 0$ expressing your answers to 3 significant figures. (4 marks)

Total 15 marks

10. (a) A shop stocks x Sonix and y Zent radios. It has shelf space for up to 20 radios.
- (i) Write an inequality to represent this information. (1 mark)
- The owner of the shop spends \$150 to purchase each Sonix radio and \$300 for each Zent radio, she has \$4 500 to spend on the purchase of these radios.
- (ii) Write an inequality to represent this information. (1 mark)
- The owner of the shop decides to stock at least 6 Sonix and at least 6 Zent radios.
- (iii) Write TWO inequalities to represent this information. (2 marks)
- (b) (i) Using a scale of 2 cm to represent 5 Sonix radios and 2 cm to represent 5 Zent radios, draw the horizontal axis for $0 \leq x \leq 30$ and the vertical axis for $0 \leq y \leq 25$. (1 mark)
- (ii) On these axes, draw the four boundary lines for the four inequalities written in (a) (i), (ii) and (iii) above. (4 marks)
- (iii) Shade the region on your graph that satisfies ALL four of the inequalities written in (a) (i), (ii) and (iii) above. (1 mark)
- (iv) State the coordinates of the vertices of the shaded region. (2 marks)
- (c) The owner of the shop sells the radios to make a profit of \$80 on each Sonix and \$100 on each Zent radio.
- (i) Express the TOTAL profit in terms of x and y . (1 mark)
- (ii) Calculate the MAXIMUM profit. (2 marks)

Total 15 marks

GEOMETRY AND TRIGONOMETRY

11.

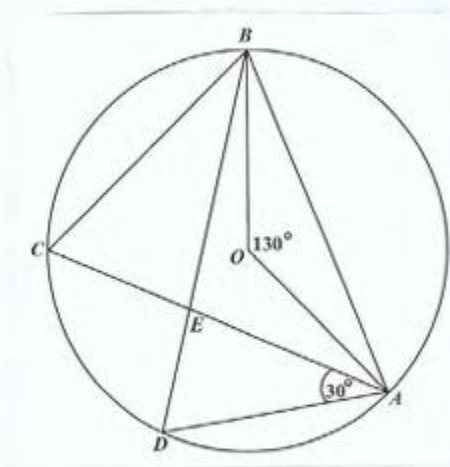

In the diagram above, **not drawn to scale**, O is the centre of the circle, $\angle AOB = 130^\circ$, $\angle DAE = 30^\circ$, and AEC and BED are chords of the circle.

- (a) Calculate the size of EACH of the following angles, giving reasons for EACH step of your answers.
- (i) $\angle ACB$ (2 marks)
 - (ii) $\angle CBD$ (2 marks)
 - (iii) $\angle AED$ (2 marks)
- (b) Show that $\triangle BCE$ and $\triangle ADE$ are similar. (3 marks)
- (c) Given that $CE = 6$ cm, $EA = 9.1$ cm and $DE = 5$ cm,
- (i) calculate the length of EB (3 marks)
 - (ii) calculate correct to 1 decimal place the area of $\triangle AED$. (3 marks)

Total 15 marks

12. In this question assume that the earth is a sphere of radius 6 370 km.

The diagram below shows a sketch of the earth with the north pole, N , and the south pole, S , labelled.

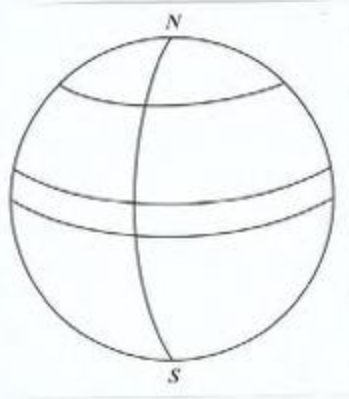

The four arcs on the diagram represent the equator, the Greenwich Meridian, latitude 6°N and latitude 52°N .

- (a) Sketch the diagram and label the
- equator
 - Greenwich Meridian
 - latitude 52°N
 - latitude 6°N . (6 marks)
- (b) The Greenwich Meridian passes through London ($52^\circ\text{N}, 0^\circ$) and Accra ($6^\circ\text{N}, 0^\circ$).
- Show on your diagram the position, L, of London and A, of Accra. (2 marks)
 - Calculate, to the NEAREST kilometre, the **shortest** distance between London and Accra along their common circle of longitude. Use $\pi = 3.14$. (4 marks)
- (c) Tropical Storm Kyle was reported to be located 5 470 km due west of Accra.
- Show on your diagram a possible point of location of Kyle, K. (1 mark)
 - Calculate the radius of the circle of latitude on which K lies. (2 marks)

Total 15 marks

GO ON TO THE NEXT PAGE

VECTORS AND MATRICES

13. The points $A(1, 2)$, $B(5, 2)$, $C(6, 4)$ and $D(2, 4)$ are the vertices of a quadrilateral $ABCD$.

- (a) Express in the form $\begin{pmatrix} x \\ y \end{pmatrix}$
- (i) the position vectors \vec{OA} , \vec{OB} , \vec{OC} , and \vec{OD} where O is the origin $(0, 0)$ (2 marks)
- (ii) the vectors \vec{AB} and \vec{DC} . (2 marks)
- (b) Calculate $|\vec{AB}|$ and hence determine the unit vector in the direction of \vec{AB} . (2 marks)
- (c) Using the answers in (a) (ii),
- (i) state TWO geometrical relationships between the line segments AB and DC (2 marks)
- (ii) explain why $ABCD$ is a parallelogram. (2 marks)
- (d) Using a vector method, determine the position vector of G , the midpoint of the line AC . Hence, state the coordinates of the point of intersection of the diagonals AC and BD of parallelogram $ABCD$. (5 marks)

Total 15 marks

14. (a) The matrix $L = \begin{pmatrix} x & 4 \\ 1 & x \end{pmatrix}$.
- (i) Calculate, in terms of x , the determinant of L .
 - (ii) Calculate the values of x given that L is singular. (3 marks)
- (b) The matrix $M = \begin{pmatrix} 3 & 1 \\ 2 & 6 \end{pmatrix}$.
- (i) Find M^{-1} , the inverse of M .
 - (ii) Hence, calculate the value of x and of y for which $M \begin{pmatrix} x \\ y \end{pmatrix} = \begin{pmatrix} 12 \\ -8 \end{pmatrix}$. (6 marks)
- (c) The image, (x', y') , of any point, (x, y) , under a transformation N is given by the equation
- $$\begin{pmatrix} x' \\ y' \end{pmatrix} = \begin{pmatrix} 2 & 0 \\ 0 & 2 \end{pmatrix} \begin{pmatrix} x \\ y \end{pmatrix} + \begin{pmatrix} 5 \\ -2 \end{pmatrix}.$$
- Calculate
- (i) the image, (x', y') , of $(3, -1)$ under N (3 marks)
 - (ii) the coordinates of the point, (x, y) , which is mapped by N onto $(7, 4)$. (3 marks)
- Total 15 marks**

END OF TEST

TEST CODE **01234020**

FORM TP 2006017

JANUARY 2006

CARIBBEAN EXAMINATIONS COUNCIL

**SECONDARY EDUCATION CERTIFICATE
EXAMINATION**

MATHEMATICS

Paper 02 – General Proficiency

Answer Sheet for Question 4

Candidate Number

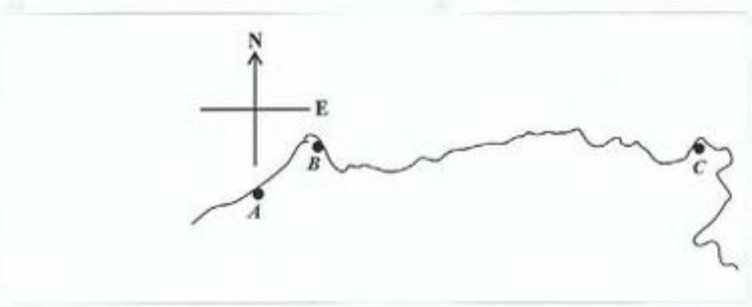

ATTACH THIS ANSWER SHEET TO YOUR ANSWER BOOKLET

01234020/JANUARY/F 2006

TEST CODE **01234020**

FORM TP 2006017

JANUARY 2006

CARIBBEAN EXAMINATIONS COUNCIL

**SECONDARY EDUCATION CERTIFICATE
EXAMINATION**

MATHEMATICS

Paper 02 – General Proficiency

Answer Sheet for Question 6

Candidate Number

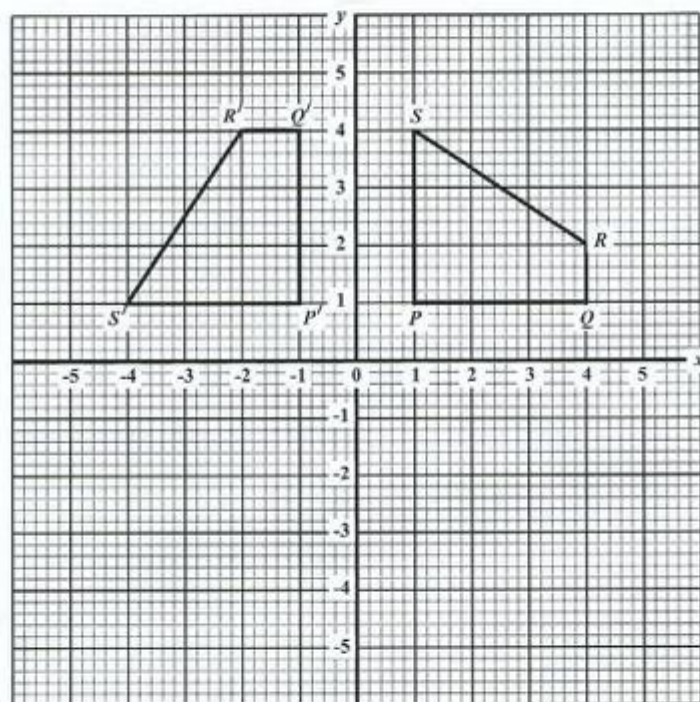

ATTACH THIS ANSWER SHEET TO YOUR ANSWER BOOKLET

FORM TP 2006109

TEST CODE **01234020**

MAY/JUNE 2006

**CARIBBEAN EXAMINATIONS COUNCIL
SECONDARY EDUCATION CERTIFICATE
EXAMINATION
MATHEMATICS**

Paper 02 – General Proficiency

2 hours 40 minutes

25 MAY 2006 (a.m.)

INSTRUCTIONS TO CANDIDATES

1. Answer ALL questions in Section I, and ANY TWO in Section II.
2. Write your answers in the booklet provided.
3. All working must be shown clearly.
4. A list of formulae is provided on page 2 of this booklet.

Examination Materials

Electronic calculator (non-programmable)
Geometry set
Mathematical tables (provided)
Graph paper (provided)

DO NOT TURN THIS PAGE UNTIL YOU ARE TOLD TO DO SO

Copyright © 2005 Caribbean Examinations Council®.
All rights reserved.

01234020/F 2006

LIST OF FORMULAE

Volume of a prism	$V = Ah$ where A is the area of a cross-section and h is the perpendicular length.
Volume of cylinder	$V = \pi r^2 h$ where r is the radius of the base and h is the perpendicular height.
Volume of a right pyramid	$V = \frac{1}{3} Ah$ where A is the area of the base and h is the perpendicular height.
Circumference	$C = 2\pi r$ where r is the radius of the circle.
Area of a circle	$A = \pi r^2$ where r is the radius of the circle.
Area of trapezium	$A = \frac{1}{2}(a + b)h$ where a and b are the lengths of the parallel sides and h is the perpendicular distance between the parallel sides.

Roots of quadratic equations	If $ax^2 + bx + c = 0$, then $x = \frac{-b \pm \sqrt{b^2 - 4ac}}{2a}$
------------------------------	---

Trigonometric ratios	$\sin \theta = \frac{\text{opposite side}}{\text{hypotenuse}}$ $\cos \theta = \frac{\text{adjacent side}}{\text{hypotenuse}}$ $\tan \theta = \frac{\text{opposite side}}{\text{adjacent side}}$
----------------------	---



Area of triangle	Area of $\Delta = \frac{1}{2}bh$ where b is the length of the base and h is the perpendicular height
------------------	--

$$\text{Area of } \Delta ABC = \frac{1}{2}ab \sin C$$

$$\text{Area of } \Delta ABC = \sqrt{s(s-a)(s-b)(s-c)}$$

$$\text{where } s = \frac{a+b+c}{2}$$

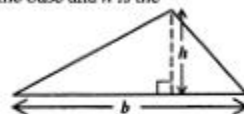

Sine rule	$\frac{a}{\sin A} = \frac{b}{\sin B} = \frac{c}{\sin C}$
-----------	--

Cosine rule	$a^2 = b^2 + c^2 - 2bc \cos A$
-------------	--------------------------------

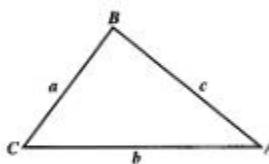

GO ON TO THE NEXT PAGE

SECTION I

Answer ALL the questions in this section.

All working must be clearly shown.

1. (a) Using a calculator, or otherwise, determine the value of $(12.3)^2 - (0.246 \div 3)$ and write the answer
- (i) exactly
- (ii) correct to two significant figures. (2 marks)

- (b) The table below gives information on the values and the rates of depreciation in value of two motor vehicles.

Motor Vehicle	Initial Value	Yearly Rate of Depreciation	Value after One Year
Taxi	\$40 000	12%	\$ p
Private Car	\$25 000	$q\%$	\$21 250

Calculate

- (i) the values of p and q
- (ii) the value of the Taxi after 2 years. (6 marks)
- (c) GUY \$1.00 = US \$0.01 and EC \$1.00 = US \$0.37.

Calculate the value of

- (i) GUY \$60 000 in US \$ (2 marks)
- (ii) US \$925 in EC \$. (2 marks)

Total 12 marks

2. (a) Simplify $\frac{x-3}{3} - \frac{x-2}{5}$. (3 marks)
- (b) (i) Factorise
- a) $x^2 - 5x$ (1 mark)
- b) $x^2 - 81$ (1 mark)
- (ii) Simplify $\frac{a^2 + 4a}{a^2 + 3a - 4}$. (3 marks)
- (c) Two cassettes and three CD's cost \$175 while four cassettes and one CD cost \$125.
- (i) Given that one cassette costs \$x and one CD costs \$y, write two equations in x and y to represent the information. (2 marks)
- (ii) Calculate the cost of one cassette. (2 marks)

Total 12 marks

3. (a) In the quadrilateral $KLMN$, not drawn to scale, $LM = LN = LK$, $\angle KLM = 140^\circ$, and $\angle LKN = 40^\circ$.

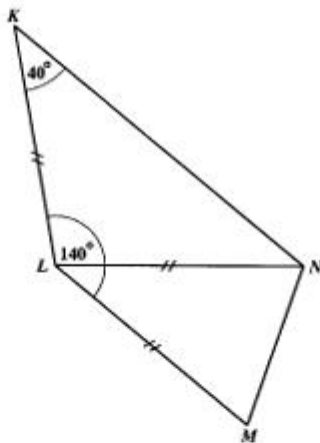

Giving the reason for each step of your answer, calculate the size of

- (i) $\angle LNK$ (2 marks)
- (ii) $\angle NLM$ (2 marks)
- (iii) $\angle KNM$. (2 marks)

GO ON TO THE NEXT PAGE

- (b) In a survey of 39 students, it was found that

18 can ride a bicycle,
 15 can drive a car,
 x can ride a bicycle and drive a car,
 $3x$ can do neither.

B is the set of students in the survey who can ride a bicycle, and C the set of students who can drive a car.

- (i) Copy and complete the Venn diagram to represent the information.

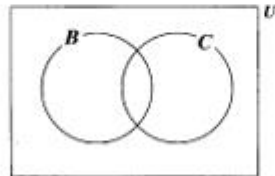

- (ii) Write an expression in x for the number of students in the survey.
 (iii) Calculate the value of x . (5 marks)

Total 11 marks

4. (a) Using a ruler, a pencil and a pair of compasses, construct the triangle ABC in which
 $AB = 8$ cm
 $\angle BAC = 60^\circ$, and
 $AC = 5$ cm
 (Credit will be given for a neat, clear diagram) (4 marks)
- (b) Measure and state the length of BC . (1 mark)
- (c) Find the perimeter of $\triangle ABC$. (1 mark)
- (d) Draw on your diagram the line CD which is perpendicular to AB and meets AB at D . (2 marks)
- (e) Determine the length of CD . (2 marks)
- (f) Calculate the area of $\triangle ABC$ giving your answer to 1 decimal point. (2 marks)

Total 12 marks

GO ON TO THE NEXT PAGE

5. The diagram below shows the graph of the function $f(x) = x^2 - 2x - 3$ for $a \leq x \leq b$. The tangent to the graph at $(2, -3)$ is also drawn.

Use the graph to determine the

- (a) values of a and b which define the domain of the graph (2 marks)
- (b) values of x for which $x^2 - 2x - 3 = 0$ (2 marks)
- (c) coordinates of the minimum point on the graph (2 marks)
- (d) whole number values of x for which $x^2 - 2x - 3 < 1$ (2 marks)
- (e) gradient of $f(x) = x^2 - 2x - 3$ at $x = 2$. (3 marks)

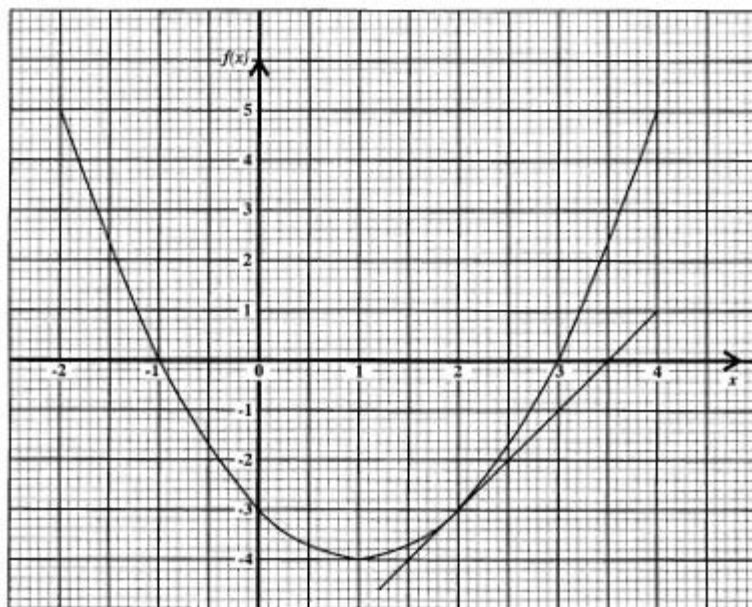

Total 11 marks

6. A man walks x km, due north, from point G to point H . He then walks $(x + 7)$ km due east from H to point F . The distance along a straight line from G to F is 13 km. The diagram below, **not drawn to scale**, shows the relative positions of G , H and F . The direction of north is also shown.

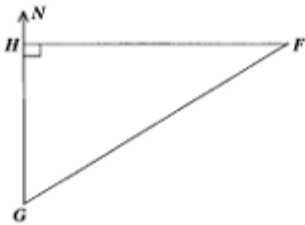

- (a) Copy the diagram and show on the diagram, the distances x km, $(x + 7)$ km and 13 km. (2 marks)
- (b) From the information on your diagram, write an equation in x which satisfies Pythagoras' Theorem. Show that the equation can be simplified to give $x^2 + 7x - 60 = 0$. (3 marks)
- (c) Solve the equation and find the distance GH . (2 marks)
- (d) Determine the bearing of F from G . (4 marks)

Total 11 marks

7. An answer sheet is provided for this question.

In an agricultural experiment, the gains in mass, of 100 cows during a certain period were recorded in kilograms as shown in the table below.

Gain in Mass (kg)	Frequency	Mid-Interval Values (kg)
5 – 9	2	7
10 – 14	29	12
15 – 19	37	17
20 – 24	16	
25 – 29	14	
30 – 34	2	

- (a) Copy and complete the mid-interval values column. (1 mark)
- (b) (i) Calculate an estimate of the mean gain in mass of the 100 cows.
Hint: EACH of the 29 cows in the “10 – 14” interval is assumed to have a mass of 12 kg. (3 marks)
- (ii) On your answer sheet, complete the drawing of the frequency polygon for the gain in mass of the cows. (5 marks)
- (c) Calculate the probability that a cow chosen at random from the experimental group gained 20 kg or more. (2 marks)

Total 11 marks

8. An answer sheet is provided for this question.

The drawings below show a sequence of squares made from toothpicks.

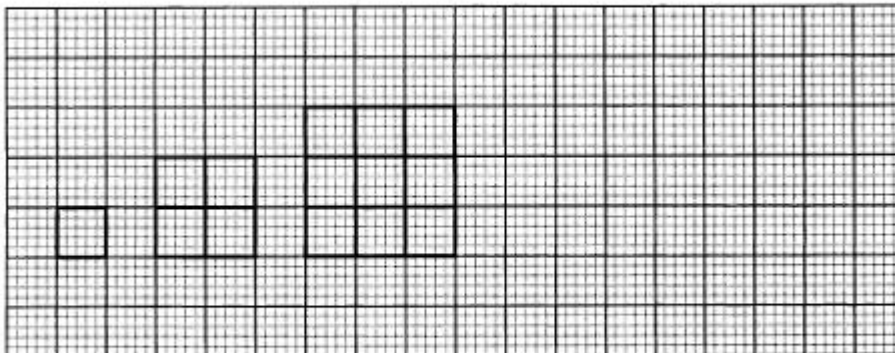

- (a) On the answer sheet provided,
- (i) draw the next shape in the sequence (2 marks)
 - (ii) insert appropriate values in columns 2 and 3 when
 - a) $n = 4$
 - b) $n = 7$ (4 marks)
- (b) Complete the table by inserting appropriate values at
- (i) r (2 marks)
 - (ii) s (2 marks)

Total 10 marks

SECTION II

Answer TWO questions in this section.

ALGEBRA AND RELATIONS, FUNCTIONS AND GRAPHS

9. (a) Solve the pair of simultaneous equations

$$y = x + 2$$

$$y = x^2.$$

(5 marks)

- (b) A strip of wire of length 32 cm is cut into two pieces. One piece is bent to form a square of side
- x
- cm. The other piece is bent to form a rectangle of length
- l
- cm and width 3 cm.

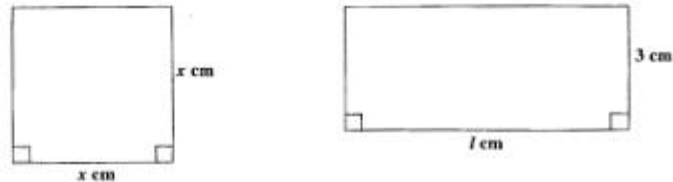
The diagrams below, **not drawn to scale**, show the square and the rectangle.

- (i) Write an expression, in terms of l and x , for the length of the strip of wire.
(2 marks)
- (ii) Show that $l = 13 - 2x$.
(2 marks)

The sum of the areas of the square and the rectangle is represented by S .

- (iii) Show that $S = x^2 - 6x + 39$.
(2 marks)
- (iv) Calculate the values of x for which $S = 30.25$.
(4 marks)

Total 15 marks

10. The owner of a parking lot wishes to park x vans and y cars for persons attending a function. The lot provides parking space for no more than 60 vehicles.

(i) Write an inequality to represent this information. (2 marks)

To get a good bargain, he must provide parking space for at least 10 cars.

(ii) Write an inequality to represent this information. (1 mark)

The number of cars parked must be fewer than or equal to twice the number of vans parked.

(iii) Write an inequality to represent this information. (2 marks)

(iv) (a) Using a scale of 2 cm to represent 10 vans on the x -axis and 2 cm to represent 10 cars on the y -axis, draw the graphs of the lines associated with the inequalities at (i), (ii) and (iii) above. (5 marks)

(b) Identify, by shading, the region which satisfies **all three** inequalities. (1 mark)

The parking fee for a van is \$6 and for a car is \$5.

(v) Write an expression in x and y for the total fees charged for parking x vans and y cars. (1 mark)

(vi) Using your graph write down the coordinates of the vertices of the shaded region. (1 mark)

(vii) Calculate the maximum fees charged. (2 marks)

Total 15 marks

GO ON TO THE NEXT PAGE

GEOMETRY AND TRIGONOMETRY

11. (a) The diagram below, **not drawn to scale**, shows a vertical tower, FT , and a vertical antenna, TW , mounted on the top of the tower.

A point P is on the same horizontal ground as F , such that $PF = 28$ m, and the angles of elevation of T and W from P are 40° and 54° respectively.

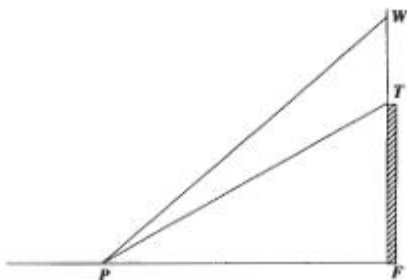

- (i) Copy and label the diagram clearly showing
- the distance 28 m
 - the angles of 40° and 54°
 - any right angles.
- (ii) Calculate the length of the antenna TW . (7 marks)

- (b) The diagram below, **not drawn to scale**, shows a circle, centre O . The lines BD and DCE are tangents to the circle, and angle $BCD = 70^\circ$.

Calculate, giving reasons for each step of your answer,

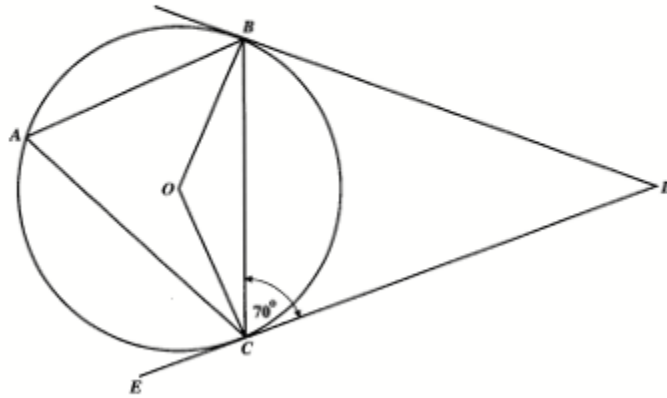

- (i) $\angle OCE$
- (ii) $\angle BAC$
- (iii) $\angle BOC$
- (iv) $\angle BDC$.

(8 marks)

Total 15 marks

12. (a) The diagram below, **not drawn to scale**, shows parallelogram $EFGH$ in which $EF = 6$ cm, $EH = 4.2$ cm, and angle $FEH = 70^\circ$.

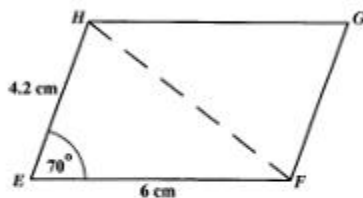

Calculate

- (i) the length of the diagonal HF (3 marks)
 - (ii) the area of the parallelogram $EFGH$. (2 marks)
- (b) In this question, use $\pi = 3.14$ and assume the earth to be a sphere of radius 6370 km.

The diagram below, **not drawn to scale**, shows a sketch of the earth with the North and South poles labelled N and S respectively. The circle of latitude $41^\circ N$ is shown. Arcs representing circles of longitude $4^\circ E$ and $74^\circ W$ are drawn but not labelled.

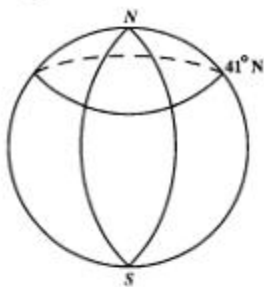

- (i) Copy the sketch above, and draw and label two arcs to represent
 - a) the Equator
 - b) the Greenwich Meridian. (2 marks)
- (ii) Two points, Y and M , on the surface of the earth have coordinates $Y(41^\circ N, 74^\circ W)$ and $M(41^\circ N, 4^\circ E)$.
 - a) Insert the points Y and M on your diagram. (2 marks)
 - b) Calculate, correct to the **nearest** kilometre, the circumference of the circle of latitude $41^\circ N$. (3 marks)
 - c) Calculate the **shortest** distance between Y and M measured along the circle of latitude $41^\circ N$. (3 marks)

Total 15 marks

GO ON TO THE NEXT PAGE

VECTORS AND MATRICES

13. The diagram below shows the position vectors of two points, A and C , relative to an origin, O .

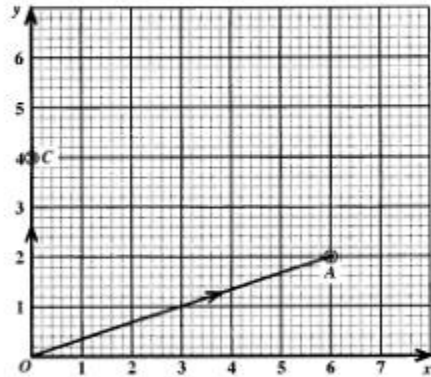

- (a) Copy and complete the diagram to show
- the point B such that $OABC$ is a parallelogram (1 mark)
 - the vector μ where $\mu = \vec{OA} + \vec{OC}$. (2 marks)
- (b) Write as a column vector, in the form $\begin{pmatrix} x \\ y \end{pmatrix}$, the vector
- \vec{OA} (1 mark)
 - \vec{OC} (1 mark)
 - \vec{AC} . (2 marks)
- (c) Given that G is the midpoint of OB , use a vector method to
- determine the coordinates of G (3 marks)
 - prove, using a vector method, that A , G , and C lie on a straight line. (5 marks)

Total 15 marks

14. (a) The value of the determinant of $M = \begin{pmatrix} 2 & 3 \\ -1 & x \end{pmatrix}$ is 9.
- (i) Calculate the value of x . (3 marks)
- (ii) For this value of x , find M^{-1} . (2 marks)
- (iii) Show that $M^{-1}M = I$. (2 marks)
- (b) The graph below shows the line segment AC and its image $A'C'$ after a transformation by the matrix $\begin{pmatrix} p & q \\ r & s \end{pmatrix}$.

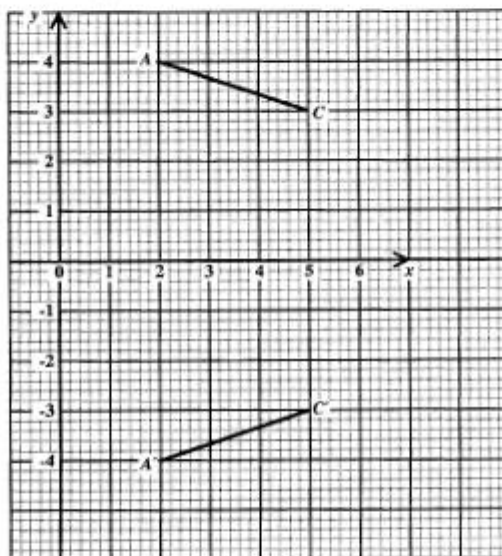

- (i) Write in the form of a single 2×2 matrix, the coordinates of
- a) A and C (2 marks)
- b) A' and C' . (2 marks)
- (ii) Using matrices only, write an equation to represent the transformation of AC onto $A'C'$. (2 marks)
- (iii) Determine the values of p , q , r and s . (2 marks)

Total 15 marks

END OF TEST



836109

01234020/F 2006

FORM TP 2006109

TEST CODE **01234020**

MAY/JUNE 2006

CARIBBEAN EXAMINATIONS COUNCIL
SECONDARY EDUCATION CERTIFICATE
EXAMINATION
MATHEMATICS

Paper 02 – General Proficiency

Answer Sheet for Question 7

Candidate Number

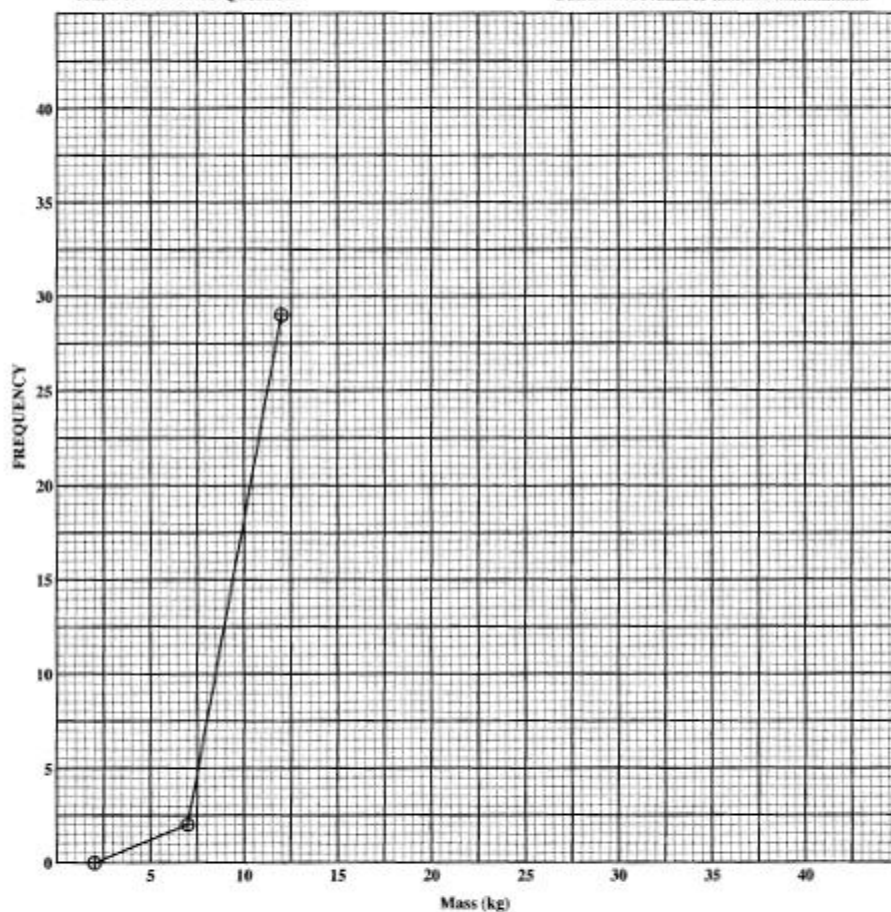

ATTACH THIS ANSWER SHEET TO YOUR ANSWER BOOKLET

CARIBBEAN EXAMINATIONS COUNCIL
SECONDARY EDUCATION CERTIFICATE
EXAMINATION
MATHEMATICS
Paper 02 – General Proficiency

Answer Sheet for Question 8

Candidate Number

8 (a) (i)

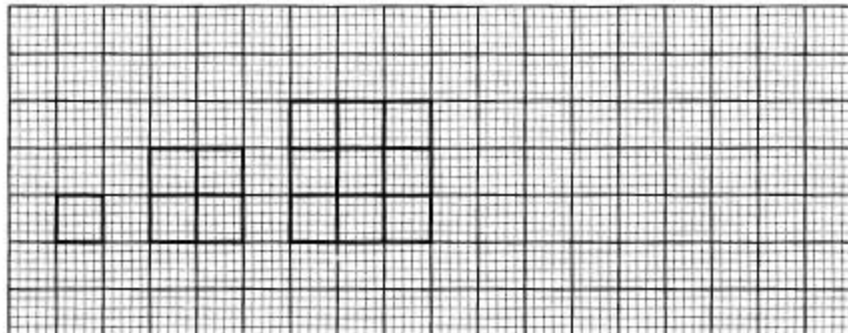

	Column 1	Column 2	Column 3
(i)	Length, n , of one side of square	Pattern for calculating the number of toothpicks in square	Total number of toothpicks in square
	1	$1 \times 2 \times 2$	4
	2	$2 \times 3 \times 2$	12
	3	$3 \times 4 \times 2$	24
a)	4		
b)	7		
(b) (i)	n	r	
(ii)	s		220

ATTACH THIS ANSWER SHEET TO YOUR ANSWER BOOKLET

FORM TP 2006107

TEST CODE **01134020**

MAY/JUNE 2006

CARIBBEAN EXAMINATIONS COUNCIL

SECONDARY EDUCATION CERTIFICATE

EXAMINATION

MATHEMATICS

Paper 02 – Basic Proficiency

2 hours 40 minutes

25 MAY 2006 (a.m.)

B

INSTRUCTIONS TO CANDIDATES

1. Answer ALL questions.
2. Write your answers in the booklet provided.
3. All working must be shown clearly.
4. A list of formulae is provided on page 2 of this booklet.

Examination Materials

Electronic calculator (non-programmable)
Geometry set
Mathematical tables (provided)
Graph paper (provided)

DO NOT TURN THIS PAGE UNTIL YOU ARE TOLD TO DO SO

Copyright © 2005 Caribbean Examinations Council®.
All rights reserved.

01134020/F 2006

LIST OF FORMULAE

Volume of a prism $V = Ah$ where A is the area of a cross-section and h is the perpendicular length.

Volume of a right pyramid $V = \frac{1}{3}Ah$ where A is the area of the base and h is the perpendicular height.

Circumference $C = 2\pi r$ where r is the radius of the circle.

Area of a circle $A = \pi r^2$ where r is the radius of the circle.

Area of trapezium $A = \frac{1}{2}(a + b)h$ where a and b are the lengths of the parallel sides and h is the perpendicular distance between the parallel sides.

Roots of quadratic equations If $ax^2 + bx + c = 0$,
then $x = \frac{-b \pm \sqrt{b^2 - 4ac}}{2a}$

Trigonometric ratios $\sin \theta = \frac{\text{opposite side}}{\text{hypotenuse}}$

$$\cos \theta = \frac{\text{adjacent side}}{\text{hypotenuse}}$$

$$\tan \theta = \frac{\text{opposite side}}{\text{adjacent side}}$$

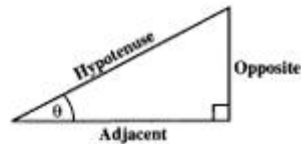

Area of triangle Area of $\Delta = \frac{1}{2}bh$ where b is the length of the base and h is the perpendicular height

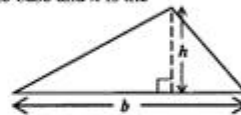

Area of sector Area = $\frac{a}{360} \times \pi r^2$

where a is measured in degrees.

Length of Arc Arc length = $\frac{a}{360} \times 2\pi r$



GO ON TO THE NEXT PAGE

SECTION I

All working must be clearly shown.

1. (a) Express 0.6 as a common fraction of 7.5, giving your answer in lowest terms. (2 marks)

- (b) Calculate the EXACT value of

$$\frac{1\frac{5}{8} + \frac{1}{4}}{\frac{3}{4}}$$

(4 marks)

- (c)

US \$1.00 = BDS \$2.00

Mrs Charles changed US \$85.00 to Barbados dollars at the rate given above.

- (i) How many Barbados dollars did she receive?

She spent BDS \$94.00 and changed the remainder to United States dollars at the same rate.

- (ii) How many US dollars did she receive? (4 marks)

Total 10 marks

2. (a) Simplify

$$\frac{x^5 \times x^4}{x^3}$$

(2 marks)

- (b) Given that $m + n = (m - n)^2$

- (i) Calculate the value of $5 + 2$ (2 marks)

- (ii) Show that $2 + 5 = 5 + 2$ (1 mark)

- (c) Solve the simultaneous equations

$$\begin{aligned} 3x + 2y &= 17 \\ x - 2y &= 3 \end{aligned}$$

(5 marks)

Total 10 marks

GO ON TO THE NEXT PAGE

3. (a) A motor car is valued at \$40 000. Its value depreciates at a rate of 10% per annum. Calculate the value of the car after two years. (4 marks)
- (b) Daveed is saving to buy a watch which costs \$78 cash.
- (i) If he saves \$6 a week, how long will he take to save enough money to buy the watch? (2 marks)

The same watch can be bought on hire purchase, by paying a deposit of \$4 followed by 15 weekly payments of \$5.50.

- (ii) Calculate the total hire purchase price of the watch. (3 marks)
- (iii) **Giving a reason**, state whether Daveed should buy the watch for cash or on hire purchase. (1 mark)

Total 10 marks

4. (a) The perimeter of a square is 20.8 cm.
- (i) What is the length of one side of the square? (2 marks)
- (ii) What is the area of the square? (2 marks)

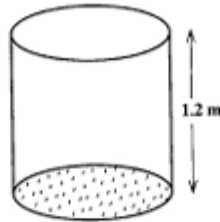

- (b) The water tank shown above has a circular base with an area of 750 cm^2 . The height of the tank is 1.2 metres.
- (i) What is the volume of the tank in cm^3 ? (3 marks)
- 54 litres of water are poured into the tank.
- (ii) Express the volume of water in cm^3 . (1 mark)
- (iii) What percentage of the volume of the tank does the water occupy? (2 marks)

Total 10 marks

GO ON TO THE NEXT PAGE

5. (a) Given that $p = -3$ and $q = 5$, calculate the value of $\frac{q-p}{q+p}$. (3 marks)
- (b) Write as a single fraction in its lowest terms
 $\frac{x+1}{2} - \frac{x}{3}$ (3 marks)
- (c) Andy is x years old. Pam is 12 years older than he.
- (i) Write an expression in x for
- a) Pam's age (1 mark)
- b) the sum of Andy's age and Pam's age. (1 mark)
- (ii) Write an equation which may be used to find x . (1 mark)
- (iii) Solve the equation to find x . (1 mark)

Total 10 marks

6. An agency charges the following rates for typing documents.

No. of pages	Cost per page
First 15	40 cents
After The First 15	30 cents

- (a) Calculate the total cost of typing a document with:
- (i) 10 pages
- (ii) 15 pages
- (iii) 23 pages (7 marks)

Mr Bob was charged \$18.00 for a document.

- (b) How many pages did the document contain? (3 marks)

Total 10 marks

7. (a) (i) Copy and complete the arrow diagram below for the ordered pairs:
(p, 1), (q, 3), (r, 2), (s, 3)

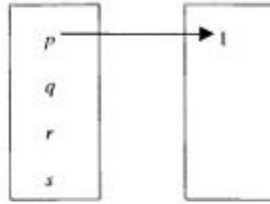

(2 marks)

- (ii) State whether the mapping drawn is many-to-one or one-to-one **giving a reason** for your answer. (2 marks)
- (b) An experiment was conducted to measure the temperature in a room over a 6-hour period. The graph below shows the results.

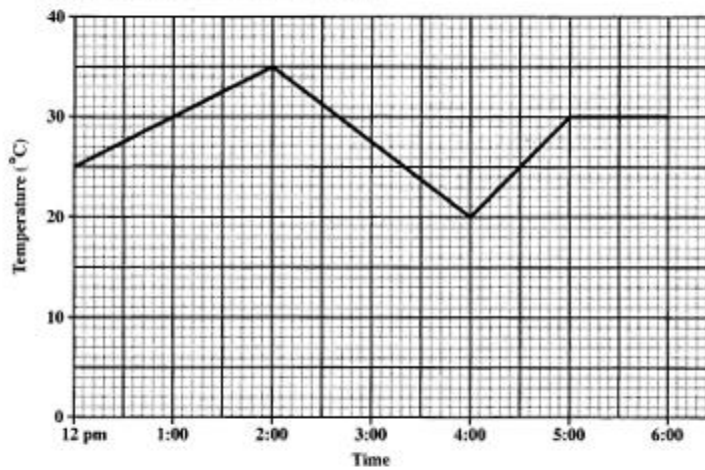

- (i) What was the temperature at the start of the experiment? (1 mark)
- (ii) What was the difference between the lowest and highest temperatures? (2 marks)
- (iii) What was the rate of decrease in temperature (in °C/hr) between 2:00 p.m. and 4:00 p.m.? (2 marks)
- (iv) During which 1-hour period was the temperature rising most quickly? (1 mark)

Total 10 marks

GO ON TO THE NEXT PAGE

8. (a) Using a pencil, a ruler and a pair of compasses, construct triangle PQR , in which $PQ = 8$ cm, angle $QPR = 60^\circ$, and $PR = 6$ cm. Measure and write down the length of QR .
(Credit will be given for a neat, clear diagram) (5 marks)
- (b) The graph shows triangle ABC and its image triangle $A'B'C'$ after undergoing a rotation.

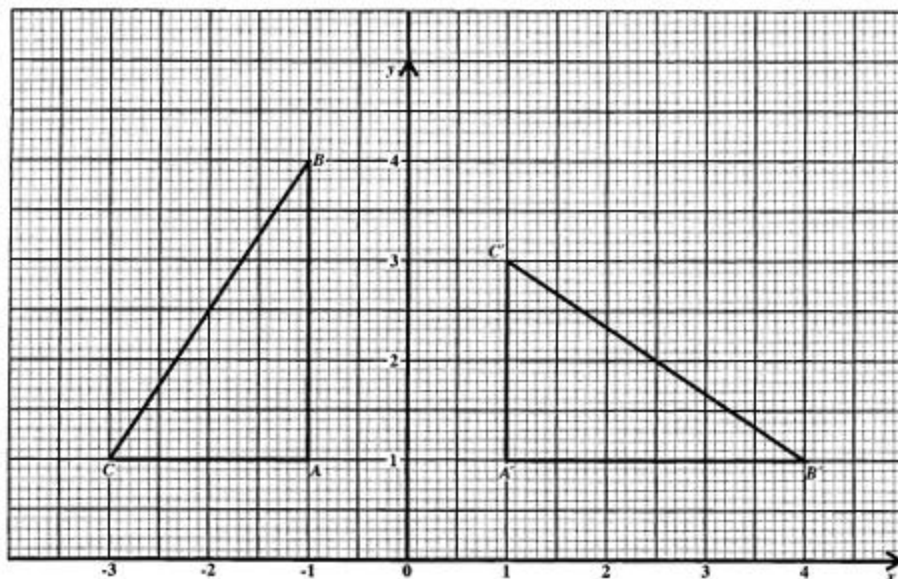

- (i) State the angle, the centre, and the direction of the rotation. (3 marks)
- (ii) Triangle $A'B'C'$ is translated by the vector $\begin{pmatrix} -1 \\ -1 \end{pmatrix}$ to form $A''B''C''$. Determine
- the length of $A''B''$ (1 mark)
 - the measurement of $\angle C''A''B''$. (1 mark)

Total 10 marks

9. An answer sheet is provided for this question.

The table below shows the number of chocolates sold by the school canteen for a given week.

Day	Monday	Tuesday	Wednesday	Thursday	Friday
No. of chocolates	22	45	58	35	60

- (a) How many **more** chocolates were sold on Friday than on Tuesday? (1 mark)
- (b) What was the **total** number of chocolates sold for the week? (2 marks)
- (c) What was the **mean** number of chocolates sold daily? (2 marks)
- (d) **On the answer sheet provided**, draw a bar chart to represent the information given in the table above. (3 marks)
- (e) What is the probability that on a day chosen at random, less than 50 chocolates were sold? (2 marks)

Total 10 marks

10. (a) The diagram below, **not drawn to scale**, shows a straight line, VW , intersecting two parallel lines, RS and TU . Calculate the value of x and of y .

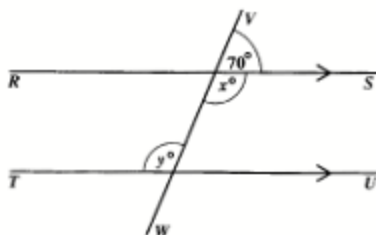

(3 marks)

- (b) In the diagram below, **not drawn to scale**, E , F , G and H are four points on horizontal ground.

F is due east of E ,
 H is due north of F ,
 G is due east of H ,
 $EH = 17$ m and $FH = 8$ m.

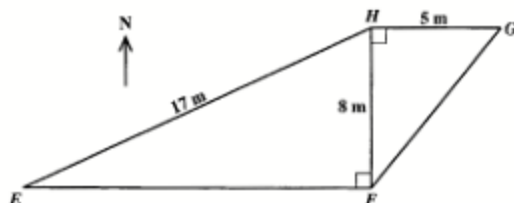

Calculate

- (i) the length of EF by using Pythagoras' theorem (3 marks)
(ii) the size of angle HGF (3 marks)
(iii) the bearing of G from F . (1 mark)

Total 10 marks

END OF TEST

TEST CODE **01134020**

FORM TP 2006107

MAY/JUNE 2006

CARIBBEAN EXAMINATIONS COUNCIL

SECONDARY EDUCATION CERTIFICATE

EXAMINATION

MATHEMATICS

Paper 02 – Basic Proficiency

Answer Sheet for Question 9

Candidate Number

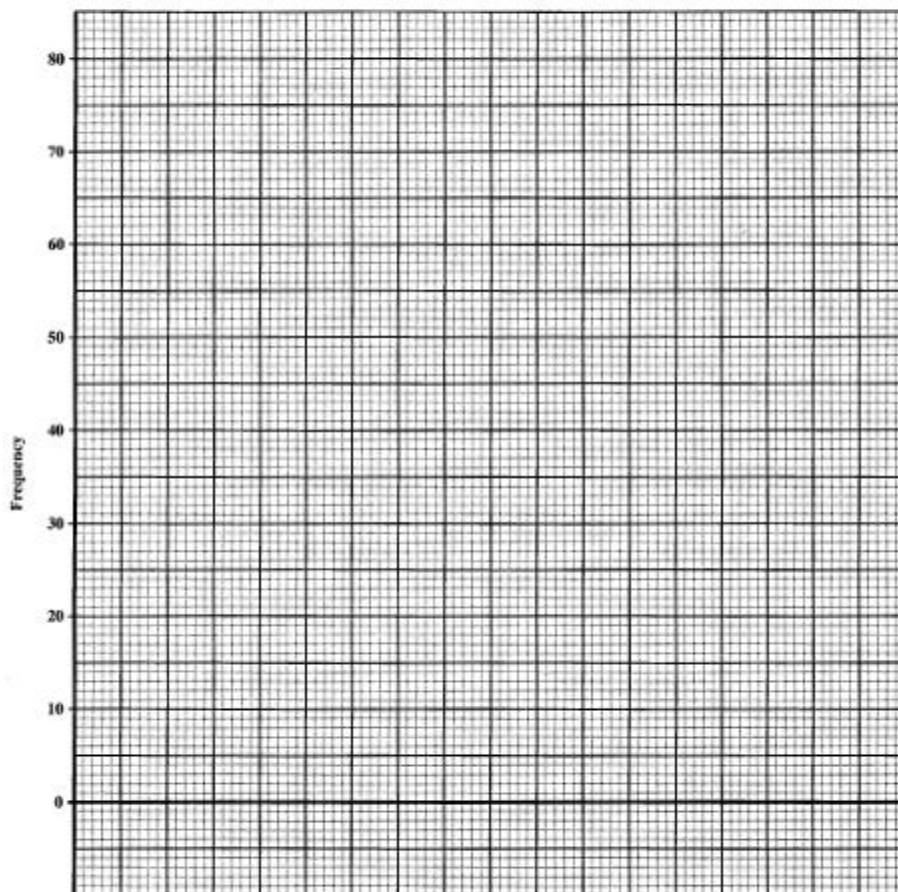

ATTACH THIS ANSWER SHEET TO YOUR ANSWER BOOKLET

01134020/F 2006

FORM TP 2007017

TEST CODE **01234020**

JANUARY 2007

**CARIBBEAN EXAMINATIONS COUNCIL
SECONDARY EDUCATION CERTIFICATE
EXAMINATION
MATHEMATICS**

Paper 02 – General Proficiency

2 hours 40 minutes

03 JANUARY 2007 (a.m.)

INSTRUCTIONS TO CANDIDATES

1. Answer ALL questions in Section I, and ANY TWO in Section II.
2. Write your answers in the booklet provided.
3. All working must be shown clearly.
4. A list of formulae is provided on page 2 of this booklet.

Examination Materials

Electronic calculator (non-programmable)
Geometry set
Mathematical tables (provided)
Graph paper (provided)

DO NOT TURN THIS PAGE UNTIL YOU ARE TOLD TO DO SO

Copyright © 2005 Caribbean Examinations Council®.
All rights reserved.

01234020/JANUARY/F 2007

LIST OF FORMULAE

Volume of a prism	$V = Ah$ where A is the area of a cross-section and h is the perpendicular length.
Volume of cylinder	$V = \pi r^2 h$ where r is the radius of the base and h is the perpendicular height.
Volume of a right pyramid	$V = \frac{1}{3} Ah$ where A is the area of the base and h is the perpendicular height.
Circumference	$C = 2\pi r$ where r is the radius of the circle.
Area of a circle	$A = \pi r^2$ where r is the radius of the circle.
Area of trapezium	$A = \frac{1}{2}(a + b)h$ where a and b are the lengths of the parallel sides and h is the perpendicular distance between the parallel sides.

Roots of quadratic equations If $ax^2 + bx + c = 0$,
then $x = \frac{-b \pm \sqrt{b^2 - 4ac}}{2a}$

Trigonometric ratios

$$\sin \theta = \frac{\text{opposite side}}{\text{hypotenuse}}$$

$$\cos \theta = \frac{\text{adjacent side}}{\text{hypotenuse}}$$

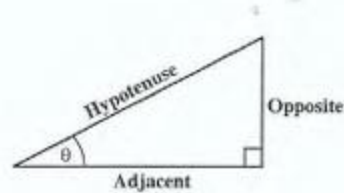
$$\tan \theta = \frac{\text{opposite side}}{\text{adjacent side}}$$

Area of triangle Area of $\Delta = \frac{1}{2}bh$ where b is the length of the base and h is the perpendicular height

$$\text{Area of } \Delta ABC = \frac{1}{2}ab \sin C$$

$$\text{Area of } \Delta ABC = \sqrt{s(s-a)(s-b)(s-c)}$$

$$\text{where } s = \frac{a+b+c}{2}$$

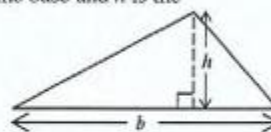

Sine rule $\frac{a}{\sin A} = \frac{b}{\sin B} = \frac{c}{\sin C}$

Cosine rule $a^2 = b^2 + c^2 - 2bc \cos A$

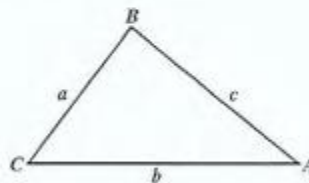

GO ON TO THE NEXT PAGE

SECTION I

Answer ALL the questions in this section.

All working must be clearly shown.

1. (a) Using a calculator, or otherwise, evaluate
- (i) $5.24(4 - 1.67)$ (2 marks)
- (ii) $\frac{1.68}{1.5^2 - 1.45}$ (3 marks)
- (b) A sum of money is shared between Aaron and Betty in the ratio 2 : 5. Aaron received \$60. How much money was shared **altogether**? (3 marks)
- (c) In St. Vincent, 3 litres of gasoline cost ECS10.40.
- (i) Calculate the cost of 5 litres of gasoline in St. Vincent, **stating your answer correct to the nearest cent.** (2 marks)
- (ii) How many litres of gasoline can be bought for EC \$50.00 in St. Vincent?
Give your answer correct to the nearest whole number. (2 marks)

Total 12 marks

2. (a) If $a = 2$, $b = -3$ and $c = 4$, evaluate
- (i) $ab - bc$ (1 mark)
- (ii) $b(a - c)^2$ (2 marks)
- (b) Solve for x where $x \in \mathbb{Z}$:
- (i) $\frac{x}{2} + \frac{x}{3} = 5$ (3 marks)
- (ii) $4 - x \leq 13$ (3 marks)
- (c) The cost of ONE muffin is $\$m$.
The cost of THREE cupcakes is $\$2m$.
- (i) Write an algebraic expression in m for the cost of:
- a) FIVE muffins (1 mark)
- b) SIX cupcakes (1 mark)
- (ii) Write an equation, in terms of m , to represent the following information.
The TOTAL cost of 5 muffins and 6 cupcakes is $\$31.50$. (1 mark)

Total 12 marks

3. (a) Describe, using set notation only, the shaded regions in each Venn diagram below. The first one is done for you.

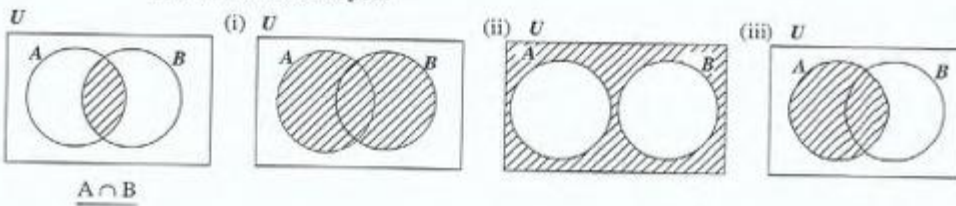

(3 marks)

- (b) The following information is given.
- $U = \{1, 2, 3, 4, 5, 6, 7, 8, 9, 10\}$
- $P = \{\text{prime numbers}\}$
- $Q = \{\text{odd numbers}\}$
- Draw a Venn diagram to represent the information above. (3 marks)

- (c) The Venn diagram below shows the number of elements in each region.

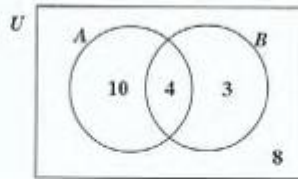

Determine how many elements are in EACH of the following sets:

- (i) $A \cup B$ (1 mark)
 (ii) $A \cap B$ (1 mark)
 (iii) $(A \cap B)'$ (1 mark)
 (iv) U (1 mark)

Total 10 marks

4. (a) (i) Using a pencil, ruler and a pair of compasses only, construct ΔABC with $BC = 6$ cm and $AB = AC = 8$ cm. (3 marks)
All construction lines must be clearly shown.
 (ii) Draw a line segment AD such that AD meets BC at D and is perpendicular to BC . (2 marks)
 (iii) Measure and state
 a) the length of the line segment AD (1 mark)
 b) the size of angle ABC (1 mark)
- (b) P is the point $(2, 4)$ and Q is the point $(6, 10)$.
 Calculate
 (i) the gradient of PQ (2 marks)
 (ii) the midpoint of PQ . (2 marks)

Total 11 marks

5. An answer sheet is provided for this question.

(a) f and g are functions defined as follows

$$f: x \rightarrow 7x + 4$$

$$g: x \rightarrow \frac{1}{2x}$$

Calculate

(i) $g(3)$ (1 mark)

(ii) $f(-2)$ (2 marks)

(iii) $f^{-1}(11)$ (2 marks)

(b) On the answer sheet provided, ΔABC is mapped onto $\Delta A'B'C'$ under a reflection.

(i) Write down the equation of the mirror line. (1 mark)

$\Delta A'B'C'$ is mapped onto $\Delta A''B''C''$ by a rotation of 180° about the point $(5, 4)$.

(ii) Determine the coordinates of the vertices of $\Delta A''B''C''$. (3 marks)

(iii) State the transformation that maps ΔABC onto $\Delta A''B''C''$. (2 marks)

Total 11 marks

6. The table below shows a frequency distribution of the scores of 100 students in an examination.

Scores	Frequency	Cumulative Frequency
21 - 25	5	5
26 - 30	18	
31 - 35	23	
36 - 40	22	
41 - 45	21	
46 - 50	11	100

- (i) Copy and complete the table above to show the cumulative frequency for the distribution. (2 marks)
- (ii) Using a scale of 2 cm to represent a score of 5 on the horizontal axis and a scale of 2 cm to represent 10 students on the vertical axis, draw a cumulative frequency curve of the scores. Start your horizontal scale at 20. (6 marks)
- (iii) Using the cumulative frequency curve, determine the median score for the distribution. (2 marks)
- (iv) What is the probability that a student chosen at random has a score greater than 40? (2 marks)

Total 12 marks

7. (a) The diagram below, **not drawn to scale**, shows a prism of length 30 cm. The cross-section $WXYZ$ is a square with area 144 cm^2 .

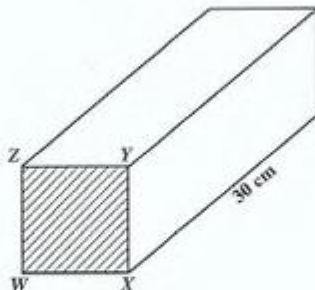

Calculate

- (i) the volume, in cm^3 , of the prism (2 marks)
- (ii) the total surface area, in cm^2 , of the prism. (4 marks)
- (b) The diagram below, **not drawn to scale**, shows the sector of a circle with centre O . $\angle MON = 45^\circ$ and $ON = 15 \text{ cm}$.

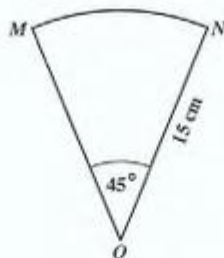

Use $\pi = 3.14$

Calculate, giving your answer correct to 2 decimal places

- (i) the length of the minor arc MN (2 marks)
- (ii) the perimeter of the figure MON (2 marks)
- (iii) the area of the figure MON . (2 marks)



Total 12 marks

8. A large equilateral triangle is subdivided into a set of smaller equilateral triangles by the following procedure:

The midpoints of the sides of each equilateral triangle are joined to form a new set of smaller triangles.

The procedure is repeated many times.

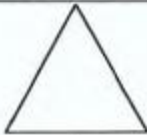
The table below shows the results when the above procedure has been repeated twice, that is, when $n = 2$.

n	Result after each step	No. of triangles formed
0		1
1		4
2		16
3		(i)
6		(ii)
(iii)		65536
m		(iv)

- (i) Calculate the number of triangles formed when $n = 3$. (2 marks)
- (ii) Determine the number of triangles formed when $n = 6$. (2 marks)
- A shape has 65 536 small triangles.
- (iii) Calculate the value of n . (3 marks)
- (iv) Determine the number of small triangles in a shape after carrying out the procedure m times. (3 marks)

Total 10 marks

GO ON TO THE NEXT PAGE

SECTION II

Answer TWO questions in this section

ALGEBRA AND RELATIONS, FUNCTIONS AND GRAPHS

9. (a) Factorise completely
- (i) $2p^2 - 7p + 3$ (1 mark)
 - (ii) $5p + 5q + p^2 - q^2$ (2 marks)
- (b) Expand $(x + 3)^2(x - 4)$, writing your answer in descending powers of x . (3 marks)
- (c) Given $f(x) = 2x^2 + 4x - 5$
- (i) write $f(x)$ in the form $f(x) = a(x + b)^2 + c$ where $a, b, c \in \mathbf{R}$ (3 marks)
 - (ii) state the equation of the axis of symmetry (1 mark)
 - (iii) state the coordinates of the minimum point (1 mark)
 - (iv) sketch the graph of $f(x)$ (2 marks)
 - (v) on the graph of $f(x)$ show clearly
 - a) the minimum point (1 mark)
 - b) the axis of symmetry. (1 mark)

Total 15 marks

10. An answer sheet is provided for this question.

Pam visits the stationery store where she intends to buy x pens and y pencils.

- (a) Pam must buy at least 3 pens.

(i) Write an inequality to represent this information. (1 mark)

The TOTAL number of pens and pencils must NOT be more than 10.

(ii) Write an inequality to represent this information. (2 marks)

EACH pen costs \$5.00 and EACH pencil costs \$2.00. More information about the pens and pencils is represented by:

$$5x + 2y \leq 35$$

(iii) Write the information represented by this inequality as a sentence in your own words. (2 marks)

- (b) (i) On the answer sheet provided, draw the graph of the TWO inequalities obtained in (a) (i) and (a) (ii) above. (3 marks)

(ii) Write the coordinates of the vertices of the region that satisfies the four inequalities (including $y \geq 0$). (2 marks)

- (c) Pam sells the x pens and y pencils and makes a profit of \$1.50 on EACH pen and \$1.00 on EACH pencil.

(i) Write an expression in x and y to represent the profit Pam makes. (1 mark)

(ii) Calculate the maximum profit Pam makes. (2 marks)

(iii) If Pam buys 4 pens, show **on your graph** the maximum number of pencils she can buy. (2 marks)

Total 15 marks

GO ON TO THE NEXT PAGE

GEOMETRY AND TRIGONOMETRY

11. (a) Two circles with centres P and Q and radii 5 cm and 2 cm respectively are drawn so that they touch each other at T and a straight line XY at S and R .

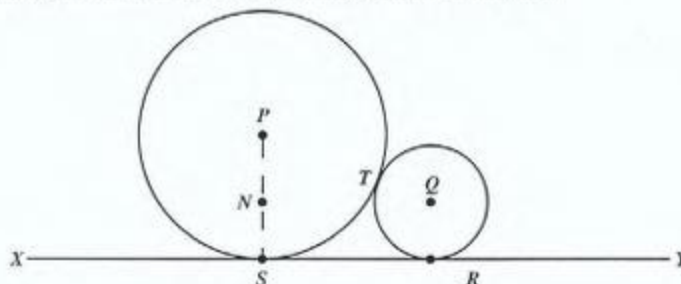

- (i) State, with a reason,
- why PTQ is a straight line (2 marks)
 - the length PQ (2 marks)
 - why PS is parallel to QR . (2 marks)
- (ii) N is a point on PS such that QN is perpendicular to PS .
Calculate
- the length PN (2 marks)
 - the length RS . (2 marks)
- (b) In the diagram below, **not drawn to scale**, O is the centre of the circle. The measure of angle LOM is 110° .

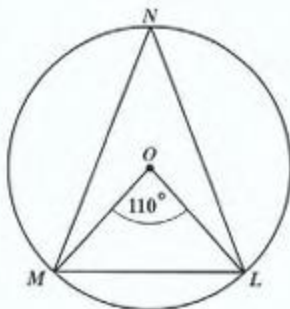

Calculate, giving reasons for your answers, the size of EACH of the following angles

- $\angle MNL$ (2 marks)
- $\angle LMO$ (3 marks)

Total 15 marks

GO ON TO THE NEXT PAGE

12. A boat leaves a dock at point A and travels for a distance of 15 km to point B on a bearing of 135° .

The boat then changes course and travels for a distance of 8 km to point C on a bearing of 060° .

- (a) Illustrate the above information in a clearly labelled diagram. (2 marks)

The diagram should show the

- (i) north direction (1 mark)
 - (ii) bearings 135° and 060° (2 marks)
 - (iii) distances 8 km and 15 km. (2 marks)
- (b) Calculate
- (i) the distance AC (3 marks)
 - (ii) $\angle BCA$ (3 marks)
 - (iii) the bearing of A from C. (2 marks)

Total 15 marks

VECTORS AND MATRICES

13. In the diagram below, M is the midpoint of \overrightarrow{ON} .

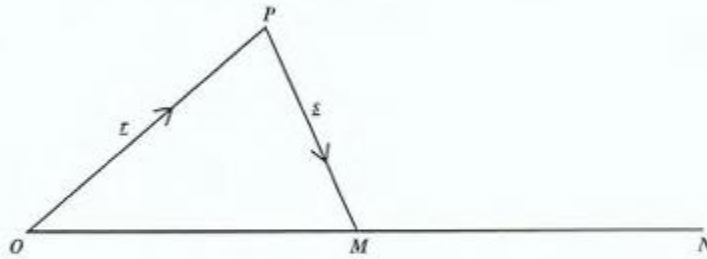

- (a) (i) Sketch the diagram above in your answer booklet and insert the point X on \overrightarrow{OM} such that $\overrightarrow{OX} = \frac{1}{3} \overrightarrow{OM}$. (1 mark)
- (ii) Produce PX to Q such that $\overrightarrow{PX} = 4 \overrightarrow{XQ}$. (1 mark)
- (b) Write the following in terms of \underline{p} and \underline{q} .
- (i) \overrightarrow{OM} (2 marks)
- (ii) \overrightarrow{PX} (3 marks)
- (iii) \overrightarrow{QM} (4 marks)
- (c) Show that $\overrightarrow{PN} = 2 \overrightarrow{PM} + \overrightarrow{OP}$ (4 marks)

Total 15 marks

14. (a) Given that $D = \begin{pmatrix} 1 & 9p \\ p & 4 \end{pmatrix}$ is a singular matrix, determine the value(s) of p .
(4 marks)

(b) Given the linear equations

$$2x + 5y = 6$$

$$3x + 4y = 8$$

(i) Write the equations in the form $AX = B$ where A , X and B are matrices.
(2 marks)

(ii) a) Calculate the determinant of the matrix A . (2 marks)

b) Show that $A^{-1} = \begin{pmatrix} \frac{-4}{7} & \frac{5}{7} \\ \frac{3}{7} & \frac{-2}{7} \end{pmatrix}$. (2 marks)

c) Use the matrix A^{-1} to solve for x and y . (5 marks)

Total 15 marks

END OF TEST

TEST CODE **01234020**

FORM TP 2007017

JANUARY 2007

CARIBBEAN EXAMINATIONS COUNCIL

**SECONDARY EDUCATION CERTIFICATE
EXAMINATION**

MATHEMATICS

Paper 02 – General Proficiency

Answer Sheet for Question 5 (b)

Candidate Number

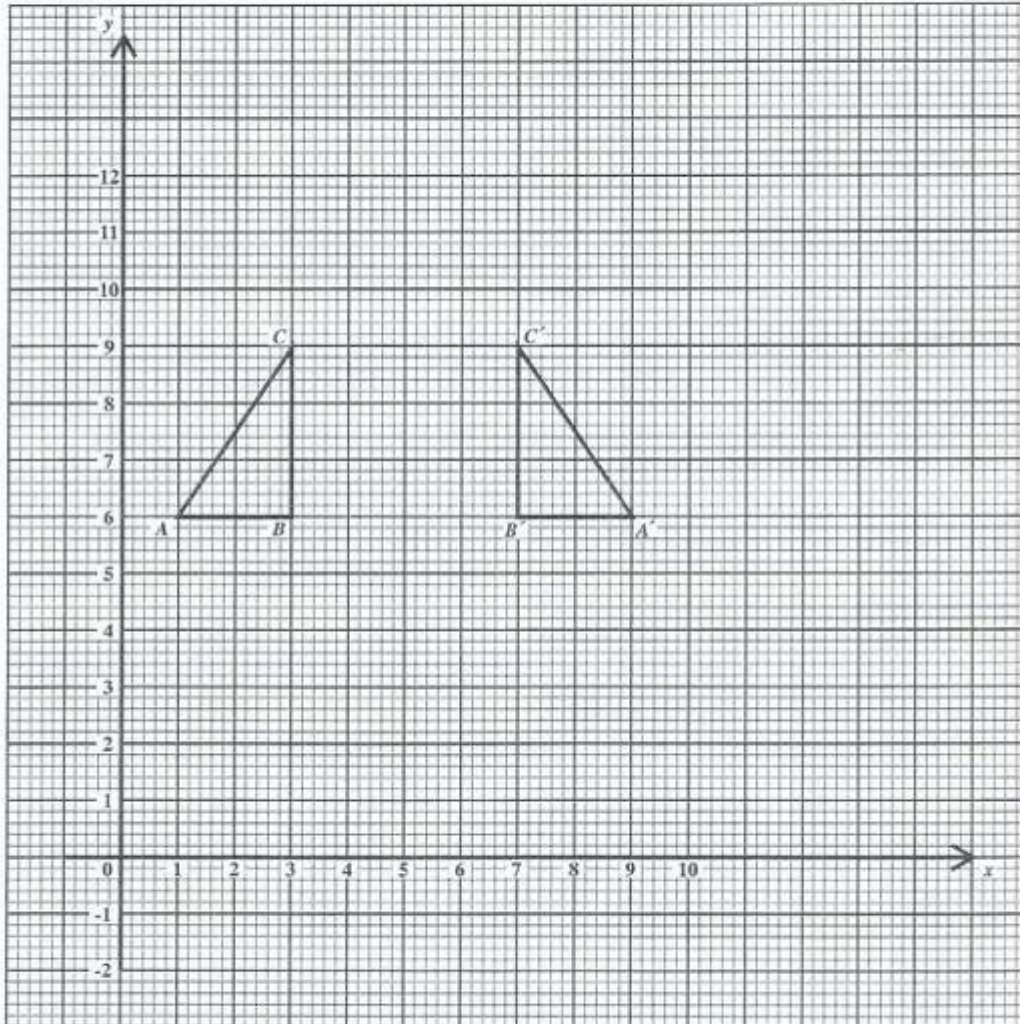

ATTACH THIS ANSWER SHEET TO YOUR ANSWER BOOKLET

01234020/JANUARY/F 2007

TEST CODE **01234020**

FORM TP 2007017

JANUARY 2007

CARIBBEAN EXAMINATIONS COUNCIL

SECONDARY EDUCATION CERTIFICATE
EXAMINATION

MATHEMATICS

Paper 02 – General Proficiency

Answer Sheet for Question 10

Candidate Number

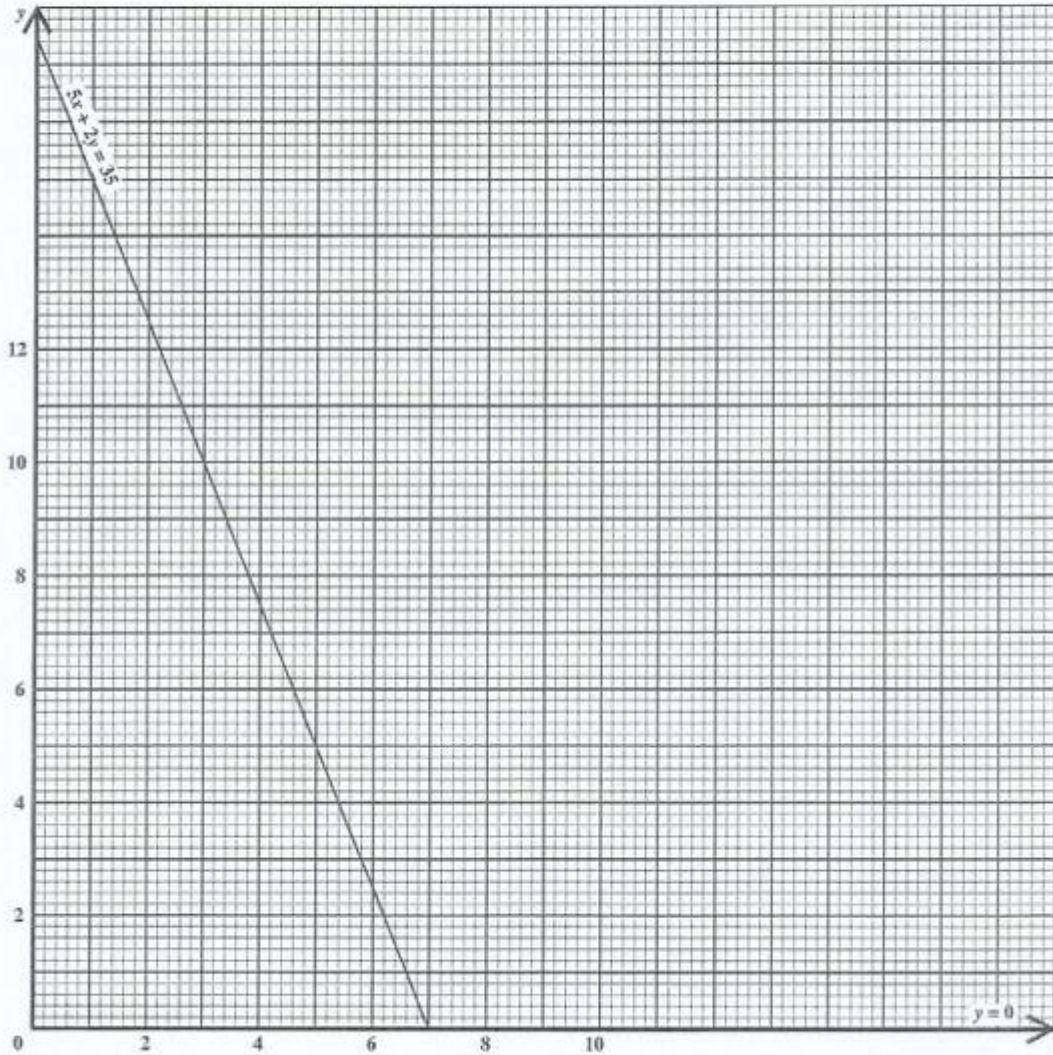

ATTACH THIS ANSWER SHEET TO YOUR ANSWER BOOKLET

01234020/JANUARY/F 2007

FORM TP 2007105

TEST CODE **01234020**

MAY/JUNE 2007

**CARIBBEAN EXAMINATIONS COUNCIL
SECONDARY EDUCATION CERTIFICATE
EXAMINATION
MATHEMATICS**

Paper 02 – General Proficiency

2 hours 40 minutes

24 MAY 2007 (a.m.)

INSTRUCTIONS TO CANDIDATES

1. Answer ALL questions in Section I, and ANY TWO in Section II.
2. Write your answers in the booklet provided.
3. All working must be shown clearly.
4. A list of formulae is provided on page 2 of this booklet.

Examination Materials

Electronic calculator (non-programmable)
Geometry set
Mathematical tables (provided)
Graph paper (provided)

DO NOT TURN THIS PAGE UNTIL YOU ARE TOLD TO DO SO.

Copyright © 2005 Caribbean Examinations Council®.
All rights reserved.

01234020/F 2007

LIST OF FORMULAE

Volume of a prism	$V = Ah$ where A is the area of a cross-section and h is the perpendicular length.
Volume of cylinder	$V = \pi r^2 h$ where r is the radius of the base and h is the perpendicular height.
Volume of a right pyramid	$V = \frac{1}{3}Ah$ where A is the area of the base and h is the perpendicular height.
Circumference	$C = 2\pi r$ where r is the radius of the circle.
Area of a circle	$A = \pi r^2$ where r is the radius of the circle.
Area of trapezium	$A = \frac{1}{2}(a + b)h$ where a and b are the lengths of the parallel sides and h is the perpendicular distance between the parallel sides.

Roots of quadratic equations	If $ax^2 + bx + c = 0$, then $x = \frac{-b \pm \sqrt{b^2 - 4ac}}{2a}$
------------------------------	---

Trigonometric ratios	$\sin \theta = \frac{\text{opposite side}}{\text{hypotenuse}}$ $\cos \theta = \frac{\text{adjacent side}}{\text{hypotenuse}}$ $\tan \theta = \frac{\text{opposite side}}{\text{adjacent side}}$
----------------------	---

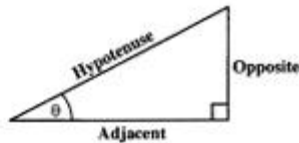

Area of triangle	Area of $\Delta = \frac{1}{2}bh$ where b is the length of the base and h is the perpendicular height
------------------	--

$$\text{Area of } \Delta ABC = \frac{1}{2}ab \sin C$$

$$\text{Area of } \Delta ABC = \sqrt{s(s-a)(s-b)(s-c)}$$

$$\text{where } s = \frac{a+b+c}{2}$$

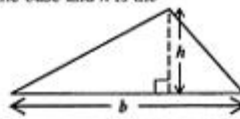

Sine rule	$\frac{a}{\sin A} = \frac{b}{\sin B} = \frac{c}{\sin C}$
-----------	--

Cosine rule	$a^2 = b^2 + c^2 - 2bc \cos A$
-------------	--------------------------------

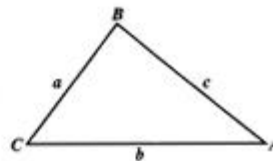

GO ON TO THE NEXT PAGE

SECTION 1

Answer ALL the questions in this section.

All working must be clearly shown.

1. (a) Using a calculator, or otherwise, determine the exact value of $(3.7)^2 - (6.24 \div 1.3)$.
(3 marks)
- (b) A total of 1 200 students attend Top View High School.
The ratio of teachers to students is 1:30.
- (i) How many teachers are there at the school? (2 marks)
- Two-fifths of the students own personal computers.
- (ii) How many students do NOT own personal computers? (2 marks)
- Thirty percent of the students who own personal computers also own play stations.
- (iii) What fraction of the students in the school own play stations?
Express your answer in its lowest terms. (4 marks)

Total 11 marks

2. (a) Given that $a * b = ab - \frac{b}{a}$,
Evaluate
- (i) $4 * 8$
- (ii) $2 * (4 * 8)$ (4 marks)
- (b) Simplify, expressing your answer in its simplest form
 $\frac{5p}{3q} + \frac{4p^2}{q}$ (2 marks)
- (c) A stadium has two sections, A and B.
Tickets for Section A cost \$ a each.
Tickets for Section B cost \$ b each.
- Johanna paid \$105 for 5 Section A tickets and 3 Section B tickets.
Raiyah paid \$63 for 4 Section A tickets and 1 Section B ticket.
- (i) Write two equations in a and b to represent the information above.
- (ii) Calculate the values of a and b . (5 marks)

Total 11 marks

GO ON TO THE NEXT PAGE

3. (a) The Venn Diagram below represents information on the type of games played by members of a youth club. All members of the club play **at least one** game.

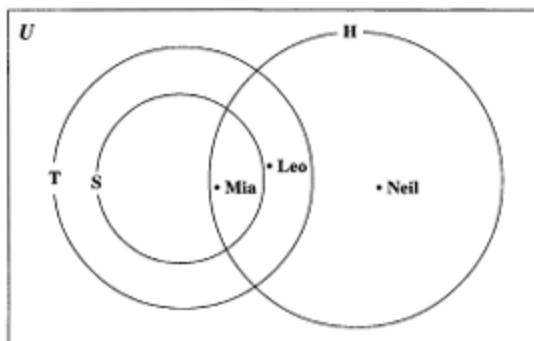

S represents the set of members who play squash.
 T represents the set of members who play tennis.
 H represents the set of members who play hockey.

Leo, Mia and Neil are three members of the youth club.

- (i) State what game(s) is/are played by
- Leo
 - Mia
 - Neil
- (ii) Describe in words the members of the set $H \cap S$. (5 marks)
- (b) (i) Using a pencil, a ruler and a pair of compasses only.
- Construct a triangle PQR in which $QR = 8.5$ cm, $PQ = 6$ cm and $PR = 7.5$ cm.
 - Construct a line PT such that PT is perpendicular to QR and meets QR at T .
- (ii)
 - Measure and state the size of angle PQR .
 - Measure and state the length of PT . (7 marks)

Total 12 marks

4. (a) The diagram below shows a map of a golf course drawn on a grid of 1 cm squares. The scale of the map is 1:4000.

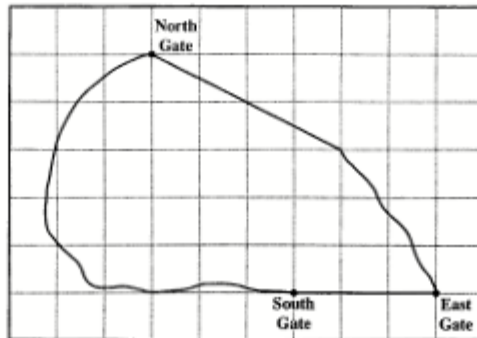

Using the map of the golf course, find

- the distance, to the nearest m, from South Gate to East Gate
- the distance, to the nearest m, from North Gate to South Gate
- the area on the ground represented by 1 cm^2 on the map
- the actual area of the golf course, giving the answer in square metres.

(6 marks)

- (b) The diagram below, **not drawn to scale**, shows a prism of volume 960 cm^3 . The cross-section ABCD is a square. The length of the prism is 15 cm.

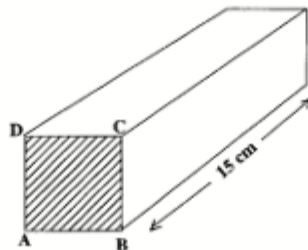

Calculate

- the length of the edge AB, in cm
- the total surface area of the prism, in cm^2 .

(5 marks)

Total 11 marks

GO ON TO THE NEXT PAGE

5. Two variables x and y are related such that 'y varies inversely as the square of x '.

- (a) Write an equation in x , y and k to describe the inverse variation, where k is the constant of variation. (2 marks)

- (b)

x	3	1.8	f
y	2	r	8

Using the information in the table above, calculate the value of

- (i) k , the constant of variation
- (ii) r
- (iii) f . (6 marks)
- (c) Determine the equation of the line which is parallel to the line $y = 2x + 3$ and passes through the coordinate (4,7). (4 marks)

Total 12 marks

6. (a) An answer sheet is provided for this question.

$L'MN'$ is the image of LMN under an enlargement.

- (i) Write on your answer sheet
- the scale factor for the enlargement
 - the coordinates of the centre of the enlargement.

$L''M''N''$ is the image of LMN under a reflection in the line $y = -x$.

- (ii) Draw and label the triangle $L''M''N''$ on your answer sheet. (5 marks)

(b)

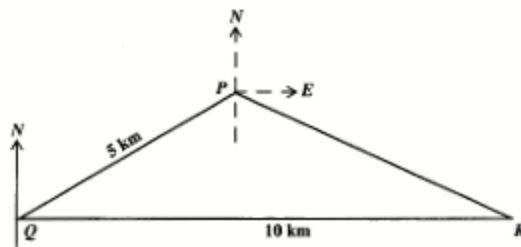

Three towns, P , Q and R are such that the bearing of P from Q is 070° . R is 10 km due east of Q and $PQ = 5$ km.

- Calculate, correct to one decimal place, the distance PR .
- Given that $\angle QPR = 142^\circ$, state the bearing of R from P . (6 marks)

Total 11 marks

7. A class of 32 students participated in running a 400 m race in preparation for their sports day. The time, in seconds, taken by each student is recorded below.

83	51	56	58	62	65	61	64
72	71	54	62	81	80	78	77
71	55	70	54	82	59	71	62
83	63	65	72	78	73	68	75

- (a) Copy and complete the frequency table to represent this data.

Time in seconds	Frequency
50 – 54	3
55 – 59	4
60 – 64	6
65 – 69	
70 – 74	
75 – 79	
80 – 84	

(2 marks)

- (b) Using the raw scores, determine the range for the data. (2 marks)
- (c) Using a scale of 2 cm to represent 5 seconds on the horizontal axis and a scale of 1 cm to represent 1 student on the vertical axis, draw a frequency polygon to represent the data.

NOTE: An empty interval must be shown at each end of the distribution and the polygon closed. (6 marks)

- (d) To qualify for the finals, a student must complete the race in less than 60 seconds. What is the probability that a student from this class will qualify for the finals? (2 marks)

Total 12 marks

8. Rectangle $WXYZ$ below represents one whole unit which has been divided into seven smaller parts. These parts are labelled A , B , C , D , E , F and G .

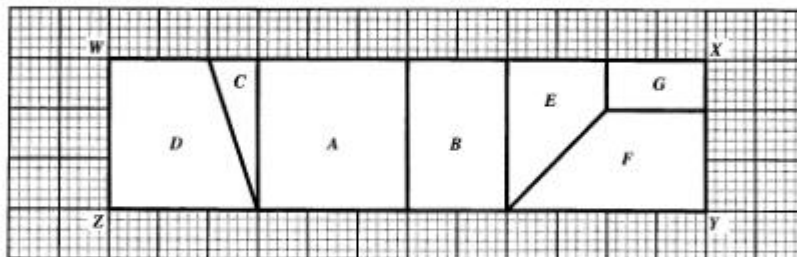

- (a) Copy and complete the following table, stating what fraction of the rectangle each part represents.

Part	Fraction
A	
B	
C	$\frac{1}{24}$
D	
E	
F	
G	$\frac{1}{18}$

(5 marks)

- (b) Write the parts in order of the size of their perimeters. (2 marks)
- (c) The area of G is 2 square units. E , F and G are rearranged to form a trapezium.
- What is the area of the trapezium in square units?
 - Sketch the trapezium clearly showing the outline of each of the three parts. (3 marks)

Total 10 marks

SECTION II

Answer TWO questions in this section.

RELATIONS, FUNCTIONS AND GRAPHS

9. (a) Given that $g(x) = \frac{2x+1}{5}$ and $f(x) = x+4$.
- (i) Calculate the value of $g(-2)$.
 - (ii) Write an expression for $gf(x)$ in its simplest form.
 - (iii) Find the inverse function $g^{-1}(x)$. (7 marks)
- (b) The length of the rectangle below is $(2x-1)$ cm and its width is $(x+3)$ cm.

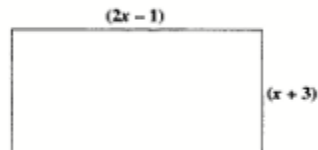

- (i) Write an expression in the form $ax^2 + bx + c$ for the area of the rectangle.
- (ii) Given that the area of the rectangle is 294 cm^2 , determine the value of x .
- (iii) Hence, state the dimensions of the rectangle, in centimetres. (8 marks)

Total 15 marks

10. A company manufactures gold and silver stars to be used as party decorations. The stars are placed in packets so that each packet contains x gold stars and y silver stars.

The conditions for packaging are given in the table below.

Condition	Inequality
(1) Each packet must have at least 20 gold stars	$x \geq 20$
(2) Each packet must have at least 15 silver stars	
(3) The total number of stars in each packet must not be more than 60.	
(4)	$x < 2y$

- (a) Write down the inequalities to represent conditions (2) and (3). (2 marks)
- (b) Describe, in words, the condition represented by the inequality $x < 2y$. (2 marks)
- (c) Using a scale of 2 cm to represent 10 units on both axes, draw the graphs of ALL FOUR inequalities represented in the table above. (7 marks)
- (d) Three packets of stars were selected for inspection. Their contents are shown below.

Packet	No. of gold stars (x)	No. of silver stars (y)
A	25	20
B	35	15
C	30	25

Plot the points A, B and C on your graph. Hence determine which of the three packets satisfy ALL the conditions. (4 marks)

Total 15 marks

GO ON TO THE NEXT PAGE

GEOMETRY AND TRIGONOMETRY

11. (a) Given that $\sin \theta = \frac{\sqrt{3}}{2}$.
- (i) Express in fractional or surd form
- a) $\cos \theta$
- b) $\tan \theta$.
- (ii) Hence, determine the exact value of $\frac{\sin \theta}{\tan \theta}$. (7 marks)
- (b) For this question take $\pi = 3.14$ and $R = 6\,370$ km, where R is the radius of the earth. The diagram below, **not drawn to scale**, shows a sketch of the earth with the North and South poles labelled N and S respectively. The circle of latitude 37°N is shown.

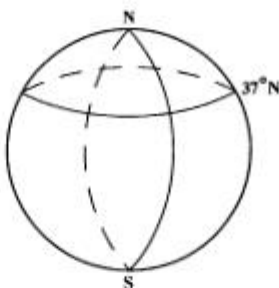

- (i) Calculate, correct to the **nearest** kilometre, the length of the circle of latitude 37°N .
- (ii) Two towns, A and B, have co-ordinates $(37^\circ\text{N}, 50^\circ\text{W})$ and $(37^\circ\text{N}, x^\circ\text{E})$ respectively. The distance from A to B measured along their common circle of latitude is 5 390 km, calculate the value of x . (8 marks)

Total 15 marks

12. (a) The figure below, **not drawn to scale**, is a regular octagon with centre X , and $XY = 6$ cm.

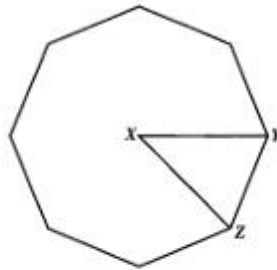

Calculate

- the size of angle YXZ
 - the area of the triangle YZX , expressing your answer correct to one decimal place
 - the area of the octagon. (6 marks)
- (b) In the diagram below, **not drawn to scale**, LM is a tangent to the circle at the point, T . O is the centre of the circle and angle $\angle MTS = 23^\circ$.

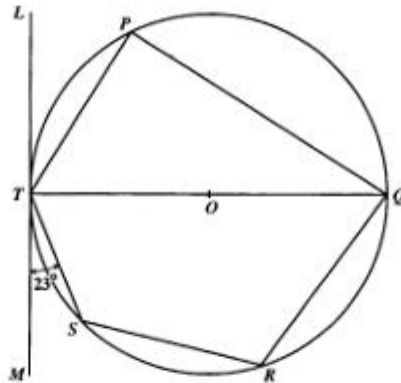

Calculate the size of each of the following angles, giving reasons for your answer

- angle TPQ
- angle MTQ
- angle TQS
- angle SRQ .

(9 marks)

Total 15 marks

GO ON TO THE NEXT PAGE

VECTORS AND MATRICES

13.

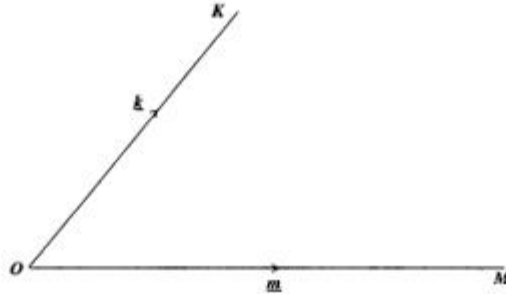

OK and OM are position vectors such that $\vec{OK} = \underline{k}$ and $\vec{OM} = \underline{m}$.

- (a) Sketch the diagram above. Show the approximate positions of points R and S such that

R is the mid-point of OK

S is a point on OM such that $\vec{OS} = \frac{1}{3}\vec{OM}$. (2 marks)

- (b) Write down, in terms of \underline{k} and \underline{m} the vectors

(i) \vec{MK}

(ii) \vec{RM}

(iii) \vec{KS}

(iv) \vec{RS} . (8 marks)

- (c) L is the mid-point of RM . Using a vector method, prove that RS is parallel to KL . (5 marks)

Total 15 marks

14. (a) A, B and C are three 2×2 matrices such that $A = \begin{pmatrix} a & b \\ c & d \end{pmatrix}$, $B = \begin{pmatrix} 5 & 3 \\ 3 & 2 \end{pmatrix}$, and $C = \begin{pmatrix} 14 & 0 \\ -9 & 5 \end{pmatrix}$.

Find

- $3A$
 - B^{-1}
 - $3A + B^{-1}$
 - the value of a, b, c and d given that $3A + B^{-1} = C$. (7 marks)
- (b) The diagram below shows a parallelogram $EFGH$ and its images after undergoing two successive transformations.

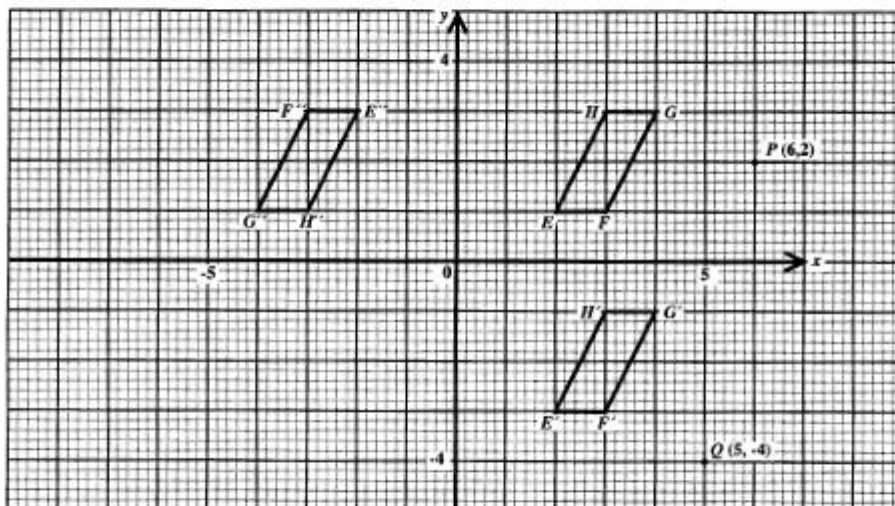

- Describe in words, the geometric transformations
 - J which maps $EFGH$ onto $E'F'G'H'$
 - K which maps $E'F'G'H'$ onto $E''F''G''H''$.
- Write the matrix which represents the transformation described above as
 - J
 - K
- The point $P(6, 2)$ is mapped onto P' by the transformation J . State the co-ordinates of P' .
- The point $Q(5, -4)$ is mapped onto Q' by the transformation K . State the co-ordinates of Q' . (8 marks)

Total 15 marks

END OF TEST

01234020/P 2007

TEST CODE **01234020**

FORM TP 2007105

MAY/JUNE 2007

**CARIBBEAN EXAMINATIONS COUNCIL
SECONDARY EDUCATION CERTIFICATE
EXAMINATION
MATHEMATICS**

Paper 02 – General Proficiency

Answer Sheet for Question 6 (a)

Candidate Number

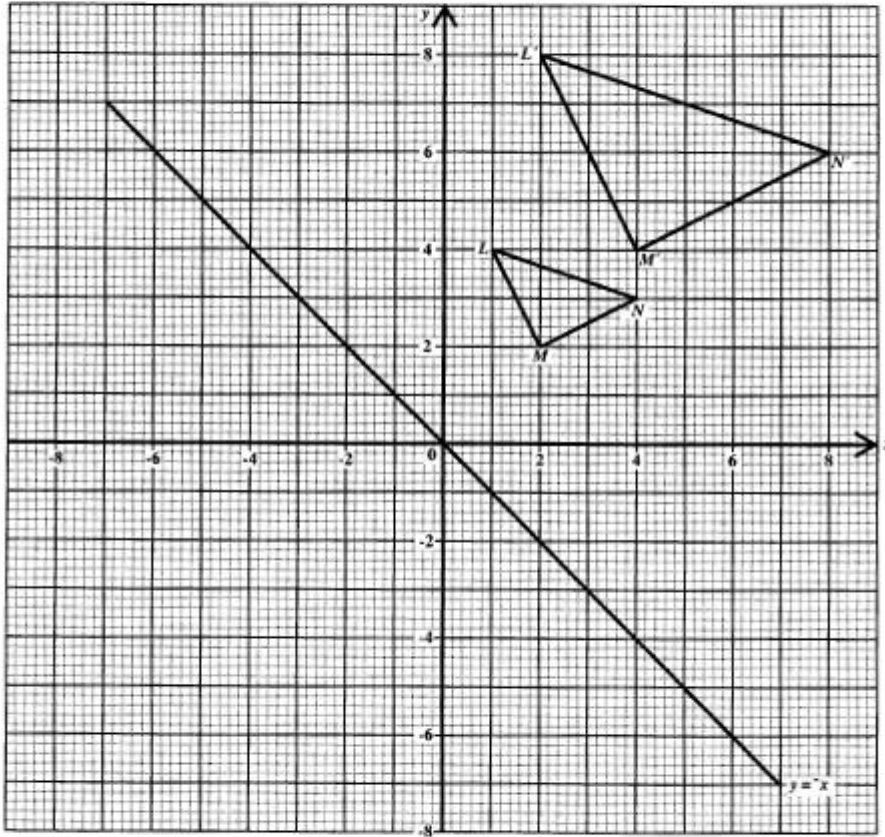

6. (a) (i) Scale factor for the enlargement

Co-ordinates of the centre of the enlargement

ATTACH THIS ANSWER SHEET TO YOUR ANSWER BOOKLET

01234020/F 2007

FORM TP 2007103

TEST CODE **01134020**

MAY/JUNE 2007

CARIBBEAN EXAMINATIONS COUNCIL

**SECONDARY EDUCATION CERTIFICATE
EXAMINATION**

MATHEMATICS

Paper 02 – Basic Proficiency

2 hours 40 minutes

24 MAY 2007 (a.m.)

B

INSTRUCTIONS TO CANDIDATES

1. Answer ALL questions.
2. Write your answers in the booklet provided.
3. All working must be shown clearly.
4. A list of formulae is provided on page 2 of this booklet.

Examination Materials

Electronic calculator (non-programmable)
Geometry set
Mathematical tables (provided)
Graph paper (provided)

DO NOT TURN THIS PAGE UNTIL YOU ARE TOLD TO DO SO

Copyright © 2005 Caribbean Examinations Council®.
All rights reserved.

01134020/F 2007

LIST OF FORMULAE

Volume of a prism $V = Ah$ where A is the area of a cross-section and h is the perpendicular length.

Volume of a right pyramid $V = \frac{1}{3}Ah$ where A is the area of the base and h is the perpendicular height.

Circumference $C = 2\pi r$ where r is the radius of the circle.

Area of a circle $A = \pi r^2$ where r is the radius of the circle.

Area of trapezium $A = \frac{1}{2}(a + b)h$ where a and b are the lengths of the parallel sides and h is the perpendicular distance between the parallel sides.

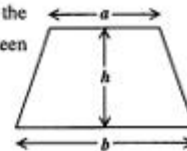
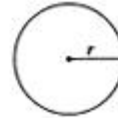

Roots of quadratic equations If $ax^2 + bx + c = 0$,
then $x = \frac{-b \pm \sqrt{b^2 - 4ac}}{2a}$

Trigonometric ratios $\sin \theta = \frac{\text{opposite side}}{\text{hypotenuse}}$

$$\cos \theta = \frac{\text{adjacent side}}{\text{hypotenuse}}$$

$$\tan \theta = \frac{\text{opposite side}}{\text{adjacent side}}$$

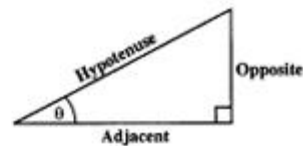

Area of triangle Area of $\Delta = \frac{1}{2}bh$ where b is the length of the base and h is the perpendicular height



Area of sector Area = $\frac{a}{360} \times \pi r^2$
where a is measured in degrees.

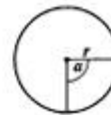

Length of Arc Arc length = $\frac{a}{360} \times 2\pi r$

GO ON TO THE NEXT PAGE

SECTION I

All working must be clearly shown.

1. (a) Using a calculator, or otherwise, find the value of 624×1.05^2 ,
writing your answer
- (i) exactly
- (ii) correct to TWO significant figures. (3 marks)
- (b) A sum of money was shared between Andy and Bob in the ratio 2:5. If Bob received \$45 more than Andy, how much money was shared? (3 marks)
- (c) Each student in a class plays **one** sport, netball or cricket or basketball. $\frac{1}{4}$ of the students play netball and $\frac{3}{8}$ of them play cricket.
- Calculate
- (i) the fraction of the students in the class who play netball and cricket
- (ii) the percentage that plays basketball. (4 marks)
- Total 10 marks**

2. (a) Simplify completely:
- (i) $2p^2 \times 3p^3$
- (ii) $\frac{p^3}{p}$
- (iii) $3(2x + 1) - 4x$. (4 marks)
- (b) Given that $a * b = ab^2$, calculate the value of $4 * (-5)$. (3 marks)
- (c) (i) Solve the inequality:
 $8 + 2x > 2 + 5x$
- (ii) Given that x is a whole number, what is the **largest** possible value of x ? (3 marks)
- Total 10 marks**

GO ON TO THE NEXT PAGE

3. (a) The cash price of a DVD player is \$340. It can be bought on hire purchase for a deposit of \$15 plus 18 monthly payments of \$20.

Calculate the **difference** between the cash price and the hire purchase price.

(3 marks)

- (b) The insurance rates for a property (house and land) are charged as follows:

Land: Fixed charge of \$100

House: 0.5% of the value of the house

Calculate the **TOTAL** insurance payable on a property if the house is valued at \$250 000.

(3 marks)

- (c) \$6 000 was deposited in a savings account which offers 5% compound interest per annum.

Calculate the **TOTAL** amount in the account after **TWO** years.

(4 marks)

Total 10 marks

4. (a) The diagram below is a map of a town showing the church, the school and the park.

1 cm on the map represents an actual distance of 2 km.

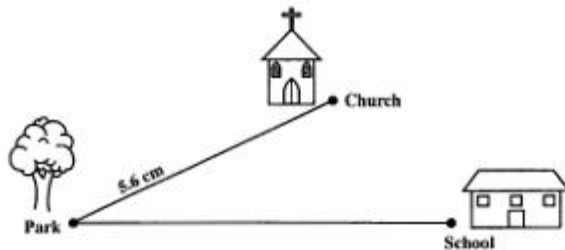

The distance from the park to the church, as shown on the map, is 5.6 cm.

- (i) Calculate the actual distance from the park to the church.

The actual distance from the park to the school is 15 km.

- (ii) What length, on the map, would be used to represent this distance?

(3 marks)

- (b) The diagram below, **not drawn to scale**, shows a square PQRS joined to a triangle QRT. PS = 8 cm and PT = 14 cm.

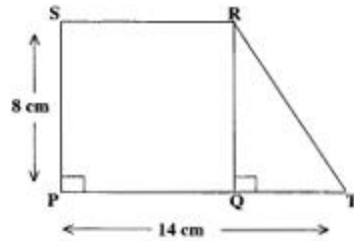

- (i) Write, in cm, the length of QT.
- (ii) Calculate the area, in cm^2 , of
- QRT
 - PTRS.
- (7 marks)

Total 10 marks

5. (a) Mr Singh works as a salesman for a basic wage of \$360 for a 45-hour week.
- Calculate the basic hourly rate of pay.
- The overtime hourly rate of pay is twice the basic hourly rate.
- Calculate the overtime hourly rate of pay.
- During a certain week Mr Singh worked 50 hours.
- Calculate the **TOTAL** wage earned for the week. (5 marks)
- (b) During a sale, Daniel bought 6 books priced at \$25 each and 3 magazines priced at \$15 each from a bookstore.
- Calculate the **TOTAL** cost of the
 - books
 - magazines.

The bookstore offered a discount of 8% on all books and magazines.

- Calculate the **TOTAL** amount Daniel actually paid for his purchases. (5 marks)

Total 10 marks

6. (a) Solve the following simultaneous equations

$$x + 2y = 7$$

$$3x + y = 6.$$

(5 marks)

- (b) A pen costs p dollars and a calculator costs 36 dollars more than the pen.

(i) Write an expression, in p , for

a) the cost of a calculator

b) the total cost of a pen and a calculator.

The total cost of the pen and the calculator is 54 dollars.

(ii) Calculate the value of p .

(5 marks)

Total 10 marks

7. (a) Triangle ABC is an isosceles triangle, where $AB = 6.5$ cm and $AC = BC = 5$ cm.

(i) Using only a pencil, a ruler and a pair of compasses, construct triangle ABC.

(ii) Measure and write down the size of the angle BAC.

(4 marks)

- (b) The diagram below, **not drawn to scale**, shows two triangles WXY and XYZ joined along the side XY . $WY = 5$ cm, $WX = 12$ cm, $\angle YWX = 90^\circ$, $\angle YZX = 90^\circ$ and $\angle XYZ = 50^\circ$.

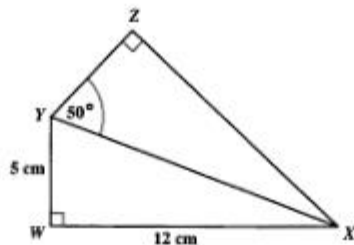

Calculate the length, in cm, of the side

(i) XY

(ii) XZ

(6 marks)

Total 10 marks

GO ON TO THE NEXT PAGE

8. (a) The diagram shows the distance-time graphs of a 200 metre race ran by two boys, Chris and Shane.

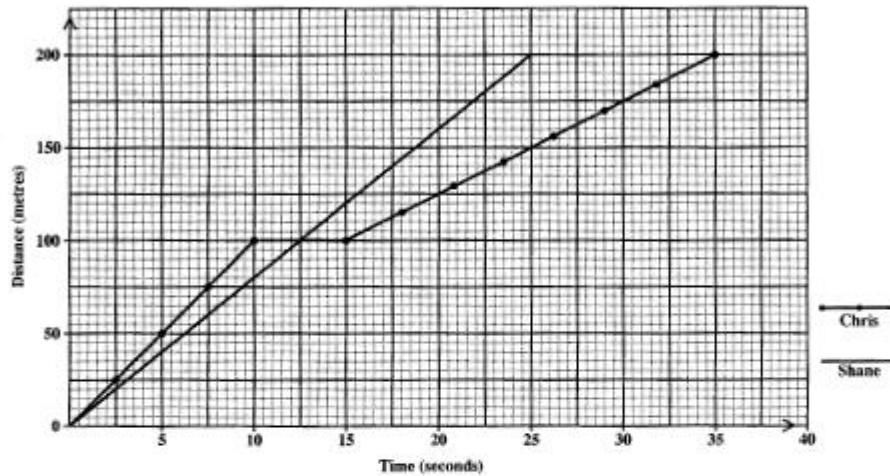

- How many seconds did Chris take to complete the race?
- How far was Chris from the finish line after 20 seconds?
- How many seconds after the start of the race were the two boys the same distance from the starting point?

During the race Shane fell.

- For how many seconds did he stay on the ground?
- What was Shane's average speed in m s^{-1} ? (6 marks)

- (b) The line PQ passes through the point $(2, 7)$ and is parallel to the line $y = 2x - 1$.

- State the gradient of PQ .
- Determine the equation of the line PQ . (4 marks)

Total 10 marks

GO ON TO THE NEXT PAGE

9. An answer sheet is provided for this question.

The figure below shows triangle KLM and its image $K'L'M'$ after undergoing a certain transformation.

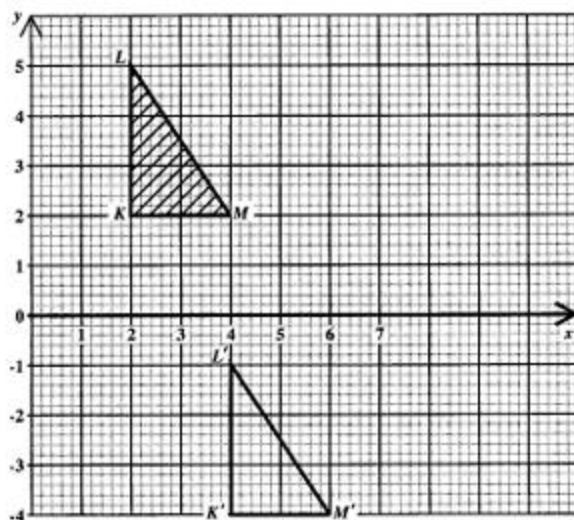

- (a) Write down the coordinates of the points K and K' . (2 marks)
- (b) A translation maps KLM to $K'L'M'$. State the column vector that represents this translation. (2 marks)
- (c) On the answer sheet provided, draw and label $K''L''M''$, the image of KLM after an enlargement centre $(0, 0)$, scale factor 2. (4 marks)
- (d) The area of triangle KLM is 3 square units. Find the area of triangle $K''L''M''$. (2 marks)

Total 10 marks

GO ON TO THE NEXT PAGE

10. (a) The pie chart below, **not drawn to scale**, shows the favourite music of a group of 60 students. The angle representing Jazz is 90° and the angle representing Calypso is 162° .

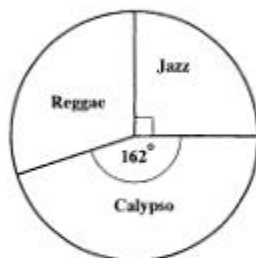

Calculate

- (i) the number of students whose favourite music is Jazz.
 - (ii) the percentage of students whose favourite music is Reggae. (5 marks)
- (b) The heights, in cm, of 20 plants are shown below

9	7	5	4	6
4	8	6	9	7
10	6	5	7	9
6	4	4	10	4

- (i) Copy and complete the frequency table below to represent the information given above.

Height	Frequency
4	5
5	2
6	
7	
8	
9	3
10	2

- (ii) Using the frequency table, determine
 - a) the median height of the plants
 - b) the probability that a plant chosen at random is more than 8 cm tall. (5 marks)

Total 10 marks

END OF TEST

01134020/F 2007

TEST CODE **01134020**

FORM TP 2007103

MAY/JUNE 2007

CARIBBEAN EXAMINATIONS COUNCIL

SECONDARY EDUCATION CERTIFICATE

EXAMINATION

MATHEMATICS

Paper 02 – Basic Proficiency

Answer Sheet for Question 9

Candidate Number

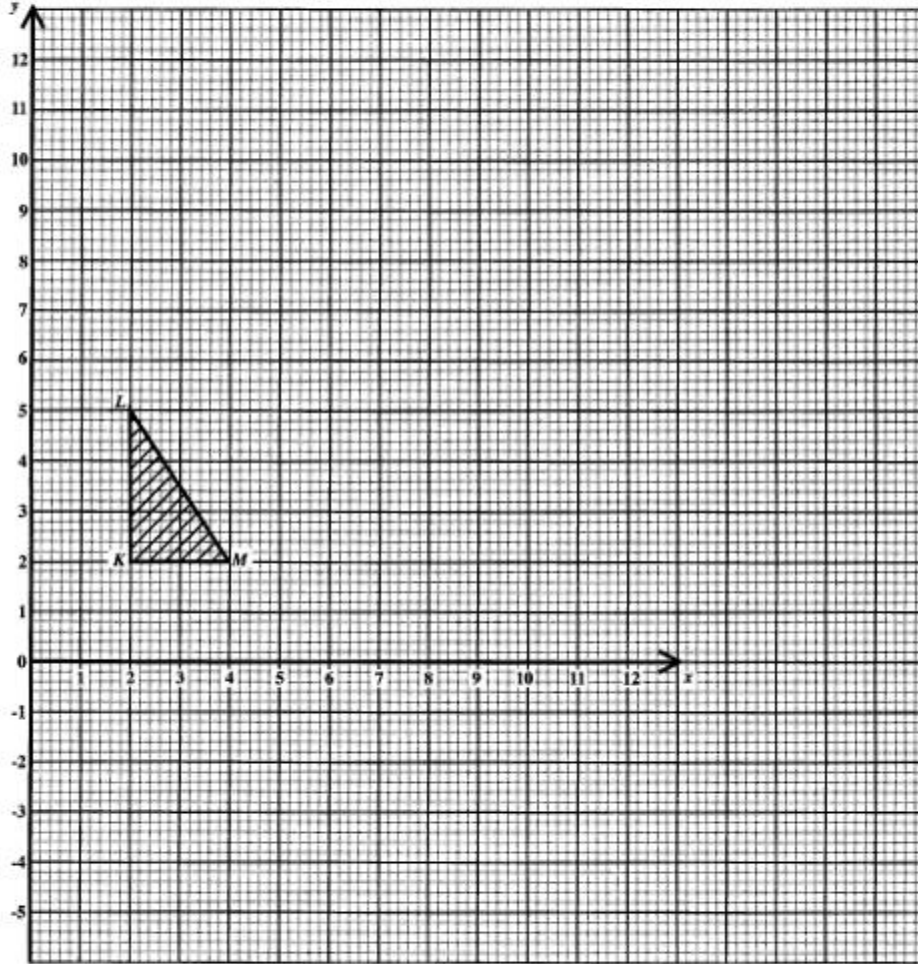

ATTACH THIS ANSWER SHEET TO YOUR ANSWER BOOKLET

01134020/F 2007

FORM TP 2008017

TEST CODE **01234020**

JANUARY 2008

**CARIBBEAN EXAMINATIONS COUNCIL
SECONDARY EDUCATION CERTIFICATE
EXAMINATION
MATHEMATICS**

Paper 02 – General Proficiency

2 hours 40 minutes

04 JANUARY 2008 (a.m.)

INSTRUCTIONS TO CANDIDATES

1. Answer ALL questions in Section I, and ANY TWO in Section II.
2. Write your answers in the booklet provided.
3. All working must be shown clearly.
4. A list of formulae is provided on page 2 of this booklet.

Examination Materials

Electronic calculator (non-programmable)
Geometry set
Mathematical tables (provided)
Graph paper (provided)

DO NOT TURN THIS PAGE UNTIL YOU ARE TOLD TO DO SO

Copyright © 2006 Caribbean Examinations Council®.
All rights reserved.

01234020/JANUARY/F 2008

LIST OF FORMULAE

Volume of a prism	$V = Ah$ where A is the area of a cross-section and h is the perpendicular length.
Volume of cylinder	$V = \pi r^2 h$ where r is the radius of the base and h is the perpendicular height.
Volume of a right pyramid	$V = \frac{1}{3} Ah$ where A is the area of the base and h is the perpendicular height.
Circumference	$C = 2\pi r$ where r is the radius of the circle.
Area of a circle	$A = \pi r^2$ where r is the radius of the circle.
Area of trapezium	$A = \frac{1}{2}(a + b)h$ where a and b are the lengths of the parallel sides and h is the perpendicular distance between the parallel sides.

Roots of quadratic equations If $ax^2 + bx + c = 0$,
then $x = \frac{-b \pm \sqrt{b^2 - 4ac}}{2a}$

Trigonometric ratios

$$\sin \theta = \frac{\text{opposite side}}{\text{hypotenuse}}$$

$$\cos \theta = \frac{\text{adjacent side}}{\text{hypotenuse}}$$

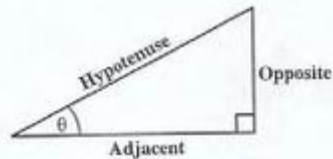
$$\tan \theta = \frac{\text{opposite side}}{\text{adjacent side}}$$

Area of triangle Area of $\Delta = \frac{1}{2}bh$ where b is the length of the base and h is the perpendicular height

$$\text{Area of } \Delta ABC = \frac{1}{2}ab \sin C$$

$$\text{Area of } \Delta ABC = \sqrt{s(s-a)(s-b)(s-c)}$$

$$\text{where } s = \frac{a+b+c}{2}$$

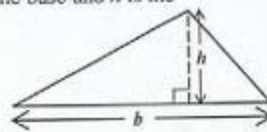

Sine rule $\frac{a}{\sin A} = \frac{b}{\sin B} = \frac{c}{\sin C}$

Cosine rule $a^2 = b^2 + c^2 - 2bc \cos A$

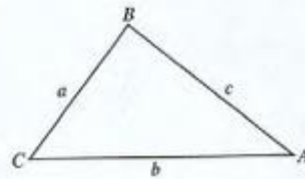

GO ON TO THE NEXT PAGE

SECTION I

Answer ALL the questions in this section.

All working must be clearly shown.

1. (a) Calculate the EXACT value of:

(i) $\frac{1\frac{1}{7} - \frac{3}{4}}{2\frac{1}{2} \times \frac{1}{5}}$ (4 marks)

(ii) $2 - \frac{0.24}{0.15}$ (2 marks)

- (b) The cash price of a bicycle is \$319.95. It can be bought on hire purchase by making a deposit of \$69.00 and 10 monthly installments of \$28.50 EACH.



- (i) What is the TOTAL hire purchase price of the bicycle? (2 marks)
- (ii) Calculate the difference between the total hire purchase price and the cash price. (1 mark)
- (iii) Express your answer in (ii) above as a percentage of the cash price. (2 marks)

Total 11 marks

2. (a) (i) Solve the inequality: $3 - 2x < 7$ (2 marks)
 (ii) If x is a whole number, determine the SMALLEST value that satisfies the inequality in (a) (i) above. (1 mark)
- (b) Factorize completely
- (i) $x^2 - xy$ (1 mark)
 (ii) $a^2 - 1$ (1 mark)
 (iii) $2p - 2q - p^2 + pq$ (2 marks)
- (c) The table below shows the types of cakes available at a bakery, the cost of each cake and the number of cakes sold for a given day.

TYPE OF CAKE	COST (\$)	NO. OF CAKES SOLD
Sponge	$(k+5)$	2
Chocolate	k	10
Fruit	$2k$	4

- (i) Write an expression, in terms of k , for the amount of money collected from the sale of sponge cakes for the day. (1 mark)
 (ii) Write an expression, in terms of k , for the TOTAL amount of money collected. (2 marks)

The total amount of money collected at the bakery for the day was \$140.00.

- (iii) Determine the value of k . (2 marks)

Total 12 marks

GO ON TO THE NEXT PAGE

3. (a) S and T are subsets of a Universal set U such that:

$$U = \{k, l, m, n, p, q, r\}$$

$$S = \{k, l, m, p\}$$

$$T = \{k, p, q\}$$

- (i) Draw a Venn diagram to represent this information. (3 marks)
- (ii) List, using set notation, the members of the set
- a) $S \cup T$ (1 mark)
- b) S' (2 marks)
- (b) The diagram below, **not drawn to scale**, shows a quadrilateral ABCD with $AB = AD$, $\angle BCD = 90^\circ$ and $\angle DBC = 42^\circ$. AB is parallel to DC.

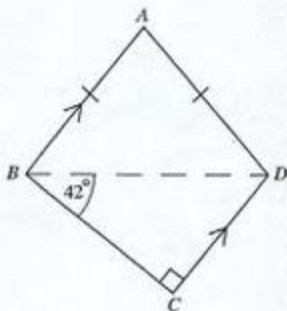

Calculate, giving reasons for your answers, the size of EACH of the following angles.

- (i) $\angle ABC$
- (ii) $\angle ABD$
- (iii) $\angle BAD$. (6 marks)

Total 12 marks

4. (a) John left Port A at 0730 hours and travels to Port B in the same time zone.
- (i) He arrives at Port B at 1420 hours. How long did the journey take? (1 mark)
- (ii) John travelled 410 kilometres. Calculate his average speed in km h^{-1} . (2 marks)
- (b) The diagram below, **not drawn to scale**, shows a circle with centre O and a square OPQR. The radius of the circle is 3.5 cm.

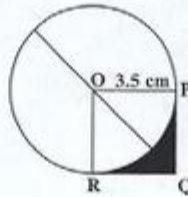

Use $\pi = \frac{22}{7}$

Calculate the area of:

- (i) the circle (2 marks)
- (ii) the square OPQR (2 marks)
- (iii) the shaded region. (3 marks)

Total 10 marks

5. In a survey, all the boys in a Book Club were asked how many books they each read during the Easter holiday. The results are shown in the bar graph below.

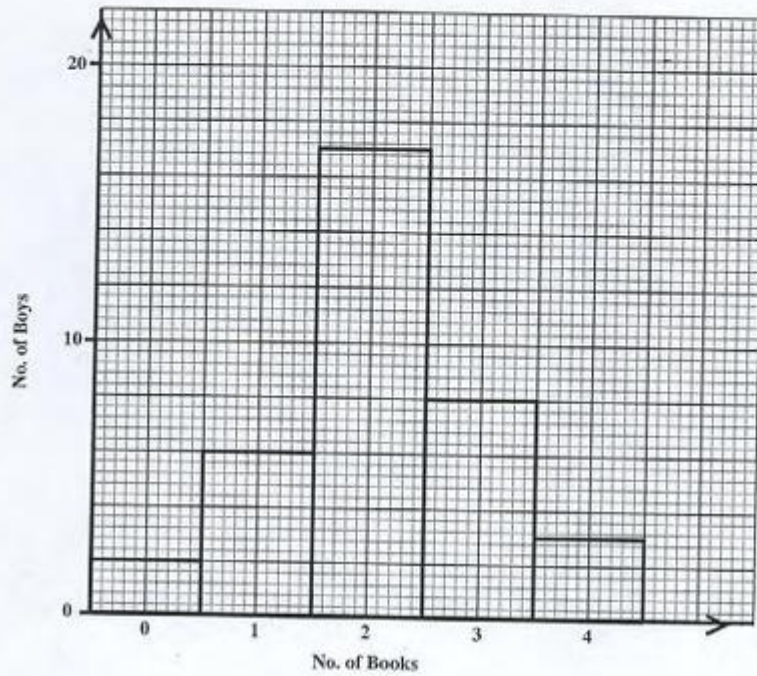

- (a) Draw a frequency table to represent the data shown in the bar graph. (3 marks)
- (b) How many boys are there in the Book Club? (2 marks)
- (c) What is the modal number of books read? (1 mark)
- (d) How many books did the boys read during the Easter holiday? (2 marks)
- (e) Calculate the mean number of books read. (2 marks)
- (f) What is the probability that a boy chosen at random read THREE OR MORE books? (2 marks)

Total 12 marks

6. (a) The diagram below shows a pattern made of congruent right-angled triangles. In each triangle, the sides meeting at a right angle are 1 unit and 2 units long.

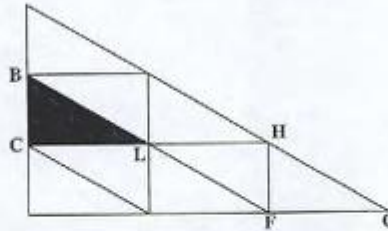

- (i) Describe FULLY the single transformation that will map triangle BCL onto triangle FHL. (3 marks)
- (ii) Describe FULLY the single transformation that will map triangle BCL onto triangle HFG. (3 marks)
- (b) (i) Using a ruler, a pencil and a pair of compasses, construct parallelogram WXYZ in which
 $WX = 7.0$ cm
 $WZ = 5.5$ cm and
 $\angle XWZ = 60^\circ$. (5 marks)
- (ii) Measure and state the length of the diagonal WY. (1 mark)

Total 12 marks

7. Given that $y = x^2 - 4x$, copy and complete the table below.

(a)

x	-1	0	1	2	3	4	5
y	5		-3	-4		0	

(3 marks)

- (b) Using a scale of 2 cm to represent 1 unit on both axes, draw the graph of the function $y = x^2 - 4x$ for $-1 \leq x \leq 5$. (4 marks)
- (c) (i) On the same axes used in (b) above, draw the line $y = 2$. (1 mark)
- (ii) State the x -coordinates of the two points at which the curve meets the line. (2 marks)
- (iii) Hence, write the equation whose roots are the x -coordinates stated in (c) (ii). (1 mark)

Total 11 marks

GO ON TO THE NEXT PAGE

8. (a) The table below shows the work done by a student in calculating the sum of the first n natural numbers.

Information is missing from some rows of the table. Study the pattern and complete, in your answer booklet, the rows marked (i) and (ii).

n	SERIES	SUM	FORMULA	
1	1	1	$\frac{1}{2}(1)(1+1)$	
2	1 + 2	3	$\frac{1}{2}(2)(2+1)$	
3	1 + 2 + 3	6	$\frac{1}{2}(3)(3+1)$	
4	1 + 2 + 3 + 4	10	$\frac{1}{2}(4)(4+1)$	
(i) 6	1 + 2 + 3 + 4 + 5 + 6	_____	_____	(3 marks)
8	1 + 2 + 3 + ... + 8	36	$\frac{1}{2}(8)(8+1)$	
(ii) n	1 + 2 + 3 + ... + n		_____	(2 marks)

- (b) After doing additional calculations, the student stated that:

$$1^3 + 2^3 + 3^3 = 36 = 6^2 \text{ and } 1^3 + 2^3 + 3^3 + 4^3 = 100 = 10^2.$$

Using the pattern observed in these two statements, determine the sum of the series:

- (i) $1^3 + 2^3 + 3^3 + 4^3 + 5^3 + 6^3 + 7^3 + 8^3$ (1 mark)
- (ii) $1^3 + 2^3 + 3^3 + \dots + n^3$. (2 marks)
- (c) Hence, or otherwise, determine the EXACT value of the sum of the series:

$$1^3 + 2^3 + 3^3 + 4^3 + \dots + 12^3 \quad (2 \text{ marks})$$

Total 10 marks

GO ON TO THE NEXT PAGE

SECTION II

There are SIX questions in this section.

Answer TWO questions in this section

ALGEBRA AND RELATIONS, FUNCTIONS AND GRAPHS

9. (a) The volume, V , of a gas varies inversely as the pressure P , when the temperature is held constant.
- Write an equation relating V and P . (2 marks)
 - If $V = 12.8$ when $P = 500$, determine the constant of variation. (2 marks)
 - Calculate the value of V when $P = 480$. (2 marks)
- (b) The lengths, in cm, of the sides of the right-angled triangle shown below are a , $(a - 7)$, and $(a + 1)$.

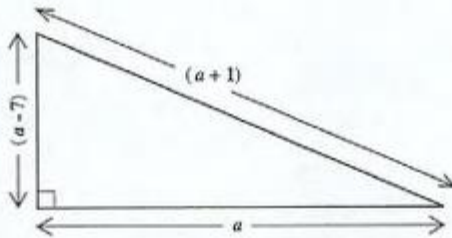

- Using Pythagoras theorem, write an equation in terms of a to represent the relationship among the three sides. (2 marks)
- Solve the equation for a . (4 marks)
- Hence, state the lengths of the THREE sides of the triangle. (3 marks)

Total 15 marks

GO ON TO THE NEXT PAGE

10. (a) A school buys x balls and y bats.
- The total number of balls and bats is no more than 30.
- (i) Write an inequality to represent this information. (2 marks)
- The school budget allows no more than \$360 to be spent on balls and bats. The cost of a ball is \$6 and the cost of a bat is \$24.
- (ii) Write an inequality to represent this information. (2 marks)
- (b) (i) Using a scale of 2 cm on the x -axis to represent 10 balls and 2 cm on the y -axis to represent 5 bats, draw the graphs of the lines associated with the inequalities at (a) (i) and (ii) above. (5 marks)
- (ii) Shade the region which satisfies the two inequalities at (a) (i) and (ii) and the inequalities $x \geq 0$ and $y \geq 0$. (1 mark)
- (iii) Use your graph to write the coordinates of the vertices of the shaded region. (2 marks)
- (c) The balls and bats are sold to students. The school makes a profit of \$1 on each ball and \$3 on each bat. The equation $P = x + 3y$ represents the total profit that may be collected from the sale of these items.
- (i) Use the coordinates of the vertices given at (b) (iii) above to determine the profit for each of those combinations. (2 marks)
- (ii) Hence, state the maximum profit that may be made. (1 mark)

Total 15 marks

GEOMETRY AND TRIGONOMETRY

11. (a) In the diagram below, **not drawn to scale**, O is the centre of the circle WXY and $\angle WXY = 50^\circ$.

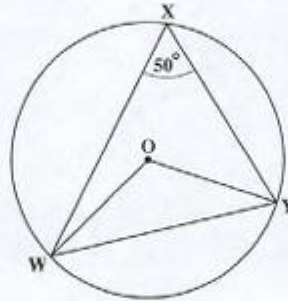

Calculate, giving a reason for EACH step of your answer,

- (i) $\angle WOY$ (2 marks)
- (ii) $\angle OWY$ (2 marks)
- (b) (i) Sketch a diagram to represent the information given below.
Show clearly all measurements and any north-south lines that may be required.
- A, B and C are three buoys.
B is 125 m due east of A.
The bearing of C from B is 190° .
CB = 75 m. (5 marks)
- (ii) Calculate, to one decimal place, the distance AC. (3 marks)
- (iii) Calculate, to the nearest degree, the bearing of C from A. (3 marks)

Total 15 marks

12. (a) The diagram below, **not drawn to scale**, shows a vertical pole, AD, and a vertical tower, BC standing on horizontal ground XABY. The height of the pole is 2.5 metres. From the point D, the angle of depression of B is 5° and the angle of elevation of C is 20° . DE is a horizontal line.

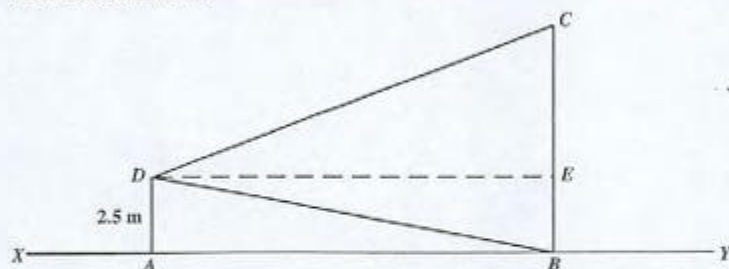

Calculate, to one decimal place

- (i) the horizontal distance AB (2 marks)
 - (ii) the height of the tower, BC. (4 marks)
- (b) The diagram below, **not drawn to scale**, shows a sketch of the earth with the North and South poles labelled N and S respectively. Arcs representing the equator, the Greenwich Meridian and the circle of latitude 50°S are also shown.

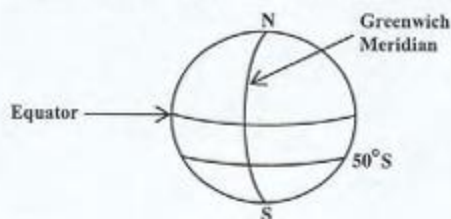

- (i) Copy the diagram above, and draw and label arcs to represent
 - a) latitude 30° North
 - b) longitude 40° East (2 marks)
- (ii) On your diagram, show the points
 - a) P(30° N, 40° E)
 - b) Q(50° S, 40° E) (2 marks)
- (iii) Calculate, **correct to the nearest kilometre**,
 - a) the shortest distance between P and Q, measured along the circle of longitude 40° E
 - b) the circumference of the circle of latitude 50° S. (5 marks)

Total 15 marks

In this question, use $\pi = 3.14$ and $R = 6\,370$ km, where R is the radius of the earth.

GO ON TO THE NEXT PAGE

VECTORS AND MATRICES

13. (a) In triangle ABC , not drawn to scale, P and Q are the mid-points of AB and BC respectively.

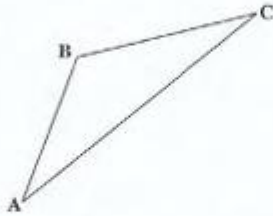

- (i) Make a sketch of the diagram and show the points P and Q . (1 mark)
- (ii) Given that $\vec{AB} = 2x$ and $\vec{BC} = 3y$, write, in terms of x and y , an expression for
- a) \vec{AC} (1 mark)
- b) \vec{PQ} (2 marks)
- (iii) Hence show that $\vec{PQ} = \frac{1}{2}\vec{AC}$ (2 marks)
- (b) The position vectors of the points R , S and T relative to the origin are

$$\vec{OR} = \begin{pmatrix} 3 \\ 4 \end{pmatrix} \quad \vec{OS} = \begin{pmatrix} -1 \\ 6 \end{pmatrix} \quad \vec{OT} = \begin{pmatrix} 5 \\ -2 \end{pmatrix}$$

- (i) Express in the form $\begin{pmatrix} a \\ b \end{pmatrix}$ the vectors
- a) \vec{RT}
- b) \vec{SR} (4 marks)
- (ii) a) The point F is such that $RF = FT$. Use a vector method to determine the position vector of F .
- b) Hence, state the coordinates of F . (5 marks)

Total 15 marks

14. A, B and C are matrices such that:

(a) $A = \begin{pmatrix} 2 & 1 \end{pmatrix}$, $B = \begin{pmatrix} 1 & x \\ y & -2 \end{pmatrix}$ and $C = \begin{pmatrix} 5 & 6 \end{pmatrix}$

Given that $AB = C$, calculate the values of x and y . (5 marks)

(b) Given the matrix $R = \begin{pmatrix} 2 & -1 \\ 1 & 3 \end{pmatrix}$,

(i) Show that R is non-singular. (2 marks)

(ii) Find R^{-1} , the inverse of R . (2 marks)

(iii) Show that $R R^{-1} = I$ (2 marks)

(iv) Using a matrix method, solve the pair of simultaneous equations

$$\begin{aligned} 2x - y &= 0 \\ x + 3y &= 7 \end{aligned}$$

(4 marks)

Total 15 marks

END OF TEST

FORM TP 2008100

TEST CODE **01234020**

MAY/JUNE 2008

**CARIBBEAN EXAMINATIONS COUNCIL
SECONDARY EDUCATION CERTIFICATE
EXAMINATION
MATHEMATICS**

Paper 02 – General Proficiency

2 hours 40 minutes

21 MAY 2008 (a.m.)

INSTRUCTIONS TO CANDIDATES

1. Answer ALL questions in Section I, and ANY TWO in Section II.
2. Write your answers in the booklet provided.
3. All working must be shown clearly.
4. A list of formulae is provided on page 2 of this booklet.

Examination Materials

Electronic calculator (non-programmable)
Geometry set
Mathematical tables (provided)
Graph paper (provided)

DO NOT TURN THIS PAGE UNTIL YOU ARE TOLD TO DO SO.

Copyright © 2006 Caribbean Examinations Council®.
All rights reserved.

01234020/F 2008

LIST OF FORMULAE

Volume of a prism	$V = Ah$ where A is the area of a cross-section and h is the perpendicular length.
Volume of cylinder	$V = \pi r^2 h$ where r is the radius of the base and h is the perpendicular height.
Volume of a right pyramid	$V = \frac{1}{3}Ah$ where A is the area of the base and h is the perpendicular height.
Circumference	$C = 2\pi r$ where r is the radius of the circle.
Area of a circle	$A = \pi r^2$ where r is the radius of the circle.
Area of trapezium	$A = \frac{1}{2}(a + b)h$ where a and b are the lengths of the parallel sides and h is the perpendicular distance between the parallel sides.

Roots of quadratic equations If $ax^2 + bx + c = 0$,
then $x = \frac{-b \pm \sqrt{b^2 - 4ac}}{2a}$

Trigonometric ratios

$$\sin \theta = \frac{\text{opposite side}}{\text{hypotenuse}}$$

$$\cos \theta = \frac{\text{adjacent side}}{\text{hypotenuse}}$$

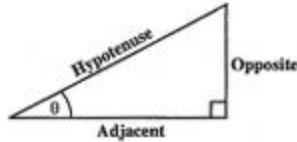
$$\tan \theta = \frac{\text{opposite side}}{\text{adjacent side}}$$

Area of triangle Area of $\Delta = \frac{1}{2}bh$ where b is the length of the base and h is the perpendicular height

$$\text{Area of } \Delta ABC = \frac{1}{2}ab \sin C$$

$$\text{Area of } \Delta ABC = \sqrt{s(s-a)(s-b)(s-c)}$$

$$\text{where } s = \frac{a+b+c}{2}$$

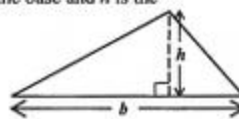

Sine rule $\frac{a}{\sin A} = \frac{b}{\sin B} = \frac{c}{\sin C}$

Cosine rule $a^2 = b^2 + c^2 - 2bc \cos A$

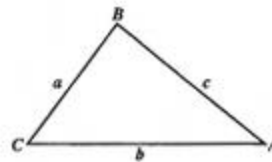

GO ON TO THE NEXT PAGE

SECTION I

Answer ALL the questions in this section.

All working must be clearly shown.

1. (a) (i) Using a calculator, or otherwise, determine the EXACT value of
 $(3.9 \times 0.27) + \sqrt{0.6724}$. (2 marks)
- (ii) Express as a single fraction
 $\frac{2\frac{1}{2} - \frac{4}{5}}{\frac{3}{4}}$. (3 marks)
- (b) In this question, use CAN \$1.00 = JA \$72.50.
- (i) On a vacation in Canada, Steve used his credit card to buy a camera for CAN \$250.00.
What is the value of the camera in Jamaican dollars? (2 marks)
- (ii) Steve's credit card limit is JA \$30 000.00. After buying the camera, how many Canadian dollars does he have left on his credit card for spending? (3 marks)

Total 10 marks

2. (a) Find the value of EACH of the following when $a = 2$, $b = -1$, $c = 3$
- (i) $a(b + c)$ (1 mark)
- (ii) $\frac{4b^2 - 2ac}{a + b + c}$. (2 marks)
- (b) Change the following statements into algebraic expressions:
- (i) Four times the sum of x and 5 (1 mark)
- (ii) 16 larger than the product of a and b (2 marks)
- (c) Solve the equation
- $$15 - 4x = 2(3x + 1).$$
- (2 marks)
- (d) Factorise completely
- (i) $6a^2b^3 + 12a^4b$ (2 marks)
- (ii) $2m^2 + 9m - 5$. (2 marks)
- Total 12 marks**

3. At a career guidance seminar, a survey was done to find out the type of careers that Form 5 students were likely to choose.

The results are shown in the table below.

Career	Lawyer	Teacher	Doctor	Artist	Salesperson
Number of students	240	189	t	216	330

There were 1 080 students surveyed.

- (a) Calculate the value of t , the number of students who were interested in becoming doctors. (2 marks)
- (b) (i) The data above are to be represented on a pie chart. Calculate the size of the angle in each sector of the pie chart. (4 marks)
- (ii) Using a circle of radius 4 cm, construct the pie chart to represent the data. (4 marks)

Total 10 marks

4. (a) A Universal set, U , is defined as
 $U = \{15, 16, 17, 18, 19, 20, 21, 22, 23, 24, 25\}$.
- Sets M and N are subsets of U such that
 $M = \{\text{Prime Numbers}\}$ and $N = \{\text{Even Numbers}\}$.
- (i) Draw a Venn diagram to represent the sets M , N and U . (5 marks)
- (ii) List the elements of the set $(M \cup N)'$. (1 mark)
- (b) (i) Using only a pair of compasses, a ruler and a pencil, construct parallelogram $ABCD$ in which $AB = AD = 7$ cm and the angle BAD is 60° . (5 marks)
- (ii) Measure and write down the length of the diagonal AC . (1 mark)

Total 12 marks

5. The diagram below, **not drawn to scale**, represents the plan of a floor. The broken line RS , divides the floor into two rectangles, **A** and **B**.

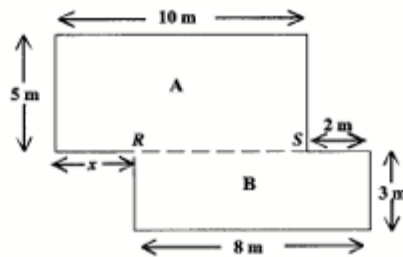

- (a) (i) Calculate the length of RS . (1 mark)
- (ii) Hence state the value of x . (1 mark)
- (b) Calculate the perimeter of the entire floor. (3 marks)
- (c) Calculate the area of the entire floor. (3 marks)
- (d) Section **A** of the floor is to be covered with flooring boards measuring 1 m by 20 cm. How many flooring boards are needed for covering Section **A**? (4 marks)

Total 12 marks

GO ON TO THE NEXT PAGE

6. (a) In the diagram below, **not drawn to scale**, GH is a vertical pole standing on a horizontal plane and H, J and K are points on the horizontal plane.

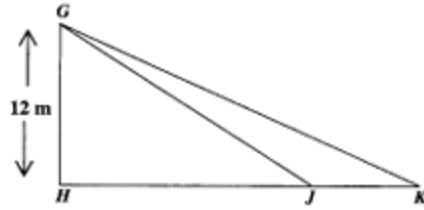

$GH = 12$ metres and the angles of elevation of the top of the pole G from J and K are 32° and 27° respectively.

- (i) Copy the diagram and insert the angles of elevation. (1 mark)
- (ii) Calculate to **one decimal place**
- the length of HJ
 - the length of JK . (5 marks)

- (b) An answer sheet is provided for this question.

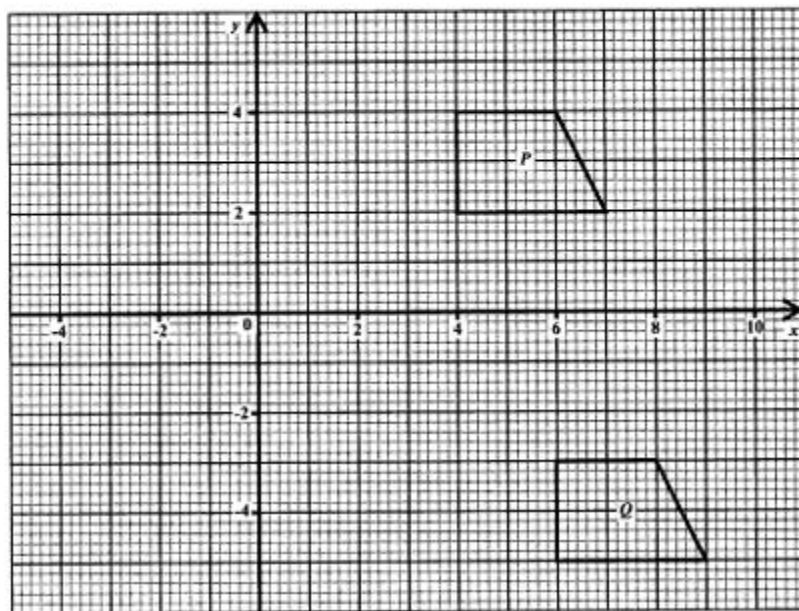

- (i) The figure labelled P undergoes a transformation, such that its image is Q . Describe this transformation completely. (2 marks)
- (ii) On the answer sheet provided, draw and label
- the line $y = x$
 - S , the image of P under a reflection in the line $y = x$. (4 marks)

Total 12 marks

7. The diagram below shows the graph of a straight line passing through the points A and B .

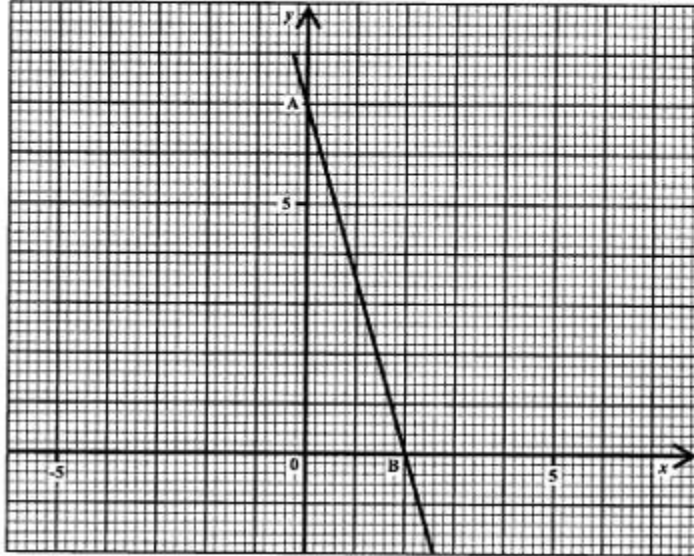

- (a) The equation of the line above is $y = mx + c$.
- State the value of c . (1 mark)
 - Determine the value of m . (2 marks)
 - Determine the coordinates of the mid-point of the line segment AB . (2 marks)
- (b) The point $(-2, k)$ lies on the line. Determine the value of k . (3 marks)
- (c) Determine the coordinates of the point of intersection of the line $y = x - 2$ and the line shown above. (4 marks)

Total 12 marks

8. Annie went to the post office and bought a collection of SIX of each of the following stamps.

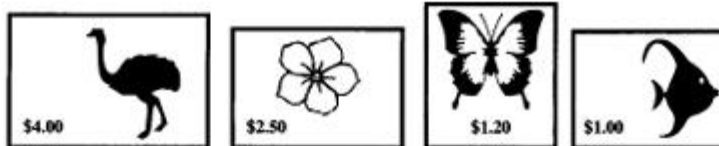

- (a) What was the TOTAL cost of the stamps? (2 marks)
- (b) She had to post a parcel and the total cost of postage was \$25.70. What stamps can she select from the collection, to make up this amount if she must use
- (i) as many \$4.00 stamps as possible? (3 marks)
- (ii) all her \$1.00 stamps? (2 marks)
- (c) (i) What is the LARGEST number of stamps that she can use from the collection to post the parcel?
- (ii) List the selection of stamps she can use. (3 marks)

Total 10 marks

SECTION II

Answer TWO questions in this section.

RELATIONS, FUNCTIONS AND GRAPHS

9. (a) Simplify
- (i) $x^2 \times x^3 \div x^4$ (1 mark)
- (ii) $a^{\frac{3}{2}}b^{\frac{5}{2}} \times \sqrt{ab^3}$. (2 marks)
- (b) If $f(x) = 2x - 3$, find the value of
- (i) $f(2)$ (1 mark)
- (ii) $f^{-1}(0)$ (2 marks)
- (iii) $f^{-1}f(2)$ (2 marks)
- (c) The temperature, K , of a liquid t minutes after heating is given in the table below.

t (time in minutes)	0	10	20	30	40	50	60
K (Temp. in °C)	84	61	40	29	27	26	25

- (i) Using a scale of 2 cm to represent 10 minutes on the horizontal axis and a scale of 2 cm to represent 10 degrees on the vertical axis, construct a temperature-time graph to show how the liquid cools in the 60 minute interval.
- Draw a smooth curve through all the plotted points. (4 marks)
- (ii) Use your graph to estimate
- a) the temperature of the liquid after 15 minutes
- b) the rate of cooling of the liquid at $t = 30$ minutes. (3 marks)

Total 15 marks

10. (a) Solve the following pair of equations for x and y :

$$y + 4x = 27$$

$$xy + x = 40$$

(6 marks)

- (b) The shaded area in the diagram below shows the solution of a set of inequalities in x and y . The variable x represents the number of boys in a cricket club and y represents the number of girls in the cricket club.

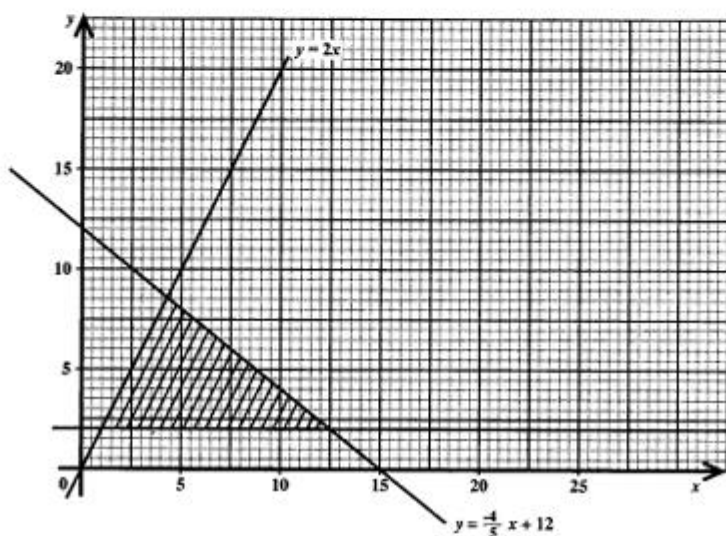

Use the graph above to answer the questions which follow.

- (i) State, **using arguments based on the graph**, whether the cricket club can have as members:
- 10 boys and 5 girls
 - 6 boys and 6 girls. (2 marks)
- (ii) Write down the set of **THREE** inequalities that define the shaded region. (4 marks)
- (iii) A company sells uniforms for the club and makes a profit of \$3.00 on a boy's uniform and \$5.00 on a girl's uniform.
- Write an expression in x and y that represents the total profit made by the company on the sale of uniforms.
 - Calculate the **minimum** profit the company can make. (3 marks)

Total 15 marks

GO ON TO THE NEXT PAGE

GEOMETRY AND TRIGONOMETRY

11. (a) In the diagram below, **not drawn to scale**, PQ is a tangent to the circle, centre O . PR is parallel to OS and angle $SPR = 26^\circ$.

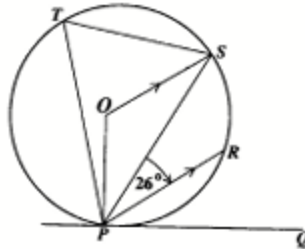

Calculate, **giving reasons for your answer**, the size of

- (i) angle PTS (2 marks)
 (ii) angle RPQ . (2 marks)
- (b) In the diagram below, **not drawn to scale**, O is the centre of the circle of radius 8.5 cm and AB is a chord of length 14.5 cm.

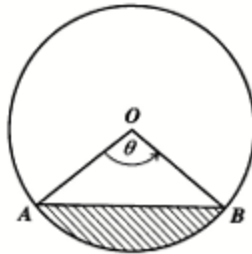

- (i) Calculate the value of θ to the nearest degree. (3 marks)
 (ii) Calculate the area of triangle AOB . (2 marks)
 (iii) Hence, calculate the area of the shaded region. [Use $\pi = 3.14$]. (3 marks)
 (iv) Calculate the length of the major arc AB . (3 marks)

Total 15 marks

12. A ship leaves Port R , sails to Port S and then to Port T .

The bearing of S from R is 112° .

The bearing of T from S is 033° .

The distance RT is 75 km and the distance RS is 56 km.

- (a) Draw a diagram showing the journey of the ship from R to S to T .
Show on your diagram
- (i) the North direction (1 mark)
 - (ii) the bearings 112° and 033° (2 marks)
 - (iii) the points R , S and T (1 mark)
 - (iv) the distances 75 km and 56 km. (1 mark)
- (b) Calculate
- (i) the size of angle RST (1 mark)
 - (ii) the size of angle RTS (3 marks)
 - (iii) the bearing of R from T . (2 marks)
- (c) The ship leaves Port T and travels due west to a point X which is due north of R .
- (i) Show on your diagram the journey from T to X . (1 mark)
 - (ii) Calculate the distance TX . (3 marks)

Total 15 marks

VECTORS AND MATRICES

13. The position vectors of A and B relative to the origin are \mathbf{a} and \mathbf{b} respectively.

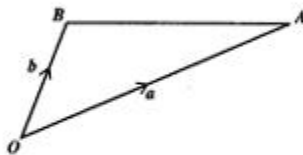

The point P is on OA such that $OP = 2PA$.
The point M is on BA such that $BM = MA$.

- (a) Copy the diagram and complete it to show the points of P and M . (2 marks)
- (b) OB is produced to N such that $OB = BN$.
- (i) Show the position of N on your diagram. (1 mark)
- (ii) Express in terms of \mathbf{a} and \mathbf{b} the vectors \vec{AB} , \vec{PA} and \vec{PM} . (5 marks)
- (c) Use a vector method to prove that P , M and N are collinear. (4 marks)
- (d) Calculate the length of AN if

$$\mathbf{a} = \begin{pmatrix} 6 \\ 2 \end{pmatrix} \text{ and } \mathbf{b} = \begin{pmatrix} 1 \\ 2 \end{pmatrix} \quad (3 \text{ marks})$$

Total 15 marks

14. (a) X and Y are two matrices where

$$X = \begin{pmatrix} -2 & 0 \\ 5 & 1 \end{pmatrix} \text{ and } Y = \begin{pmatrix} 4 & -1 \\ 3 & 7 \end{pmatrix}.$$

Evaluate $X^2 + Y$. (4 marks)

- (b) The matrix $\begin{pmatrix} 1 & 2 \\ 1 & 3 \end{pmatrix}$ maps $Q(1, 2)$ to $Q'(5, 7)$.

Find the 2×2 matrix which maps Q' back to Q . (2 marks)

- (c) The vertices of triangle DEF are

$D(5, 12)$, $E(2, 7)$ and $F(8, 4)$.

- (i) Triangle DEF undergoes an enlargement with centre, O , and scale factor, k . Its image is $D'E'F'$ where

$$D(5, 12) \rightarrow D'(7.5, 18).$$

a) Determine the value of k .

b) Hence write down the coordinates of E' and F' . (4 marks)

- (ii) $D'E'F'$ undergoes a clockwise rotation of 90° about the origin.

a) Determine the 2×2 matrix that represents a clockwise rotation of 90° about the origin.

b) Determine the coordinates of $D''E''F''$, the image of $D'E'F'$, under this rotation.

c) Determine the 2×2 matrix that maps triangle DEF onto triangle $D''E''F''$. (5 marks)

Total 15 marks

END OF TEST

TEST CODE **01234020**

MAY/JUNE 2008

FORM TP 2008100

CARIBBEAN EXAMINATIONS COUNCIL

SECONDARY EDUCATION CERTIFICATE

EXAMINATION

MATHEMATICS

Paper 02 – General Proficiency

Answer Sheet for Question 6 (b)

Candidate Number

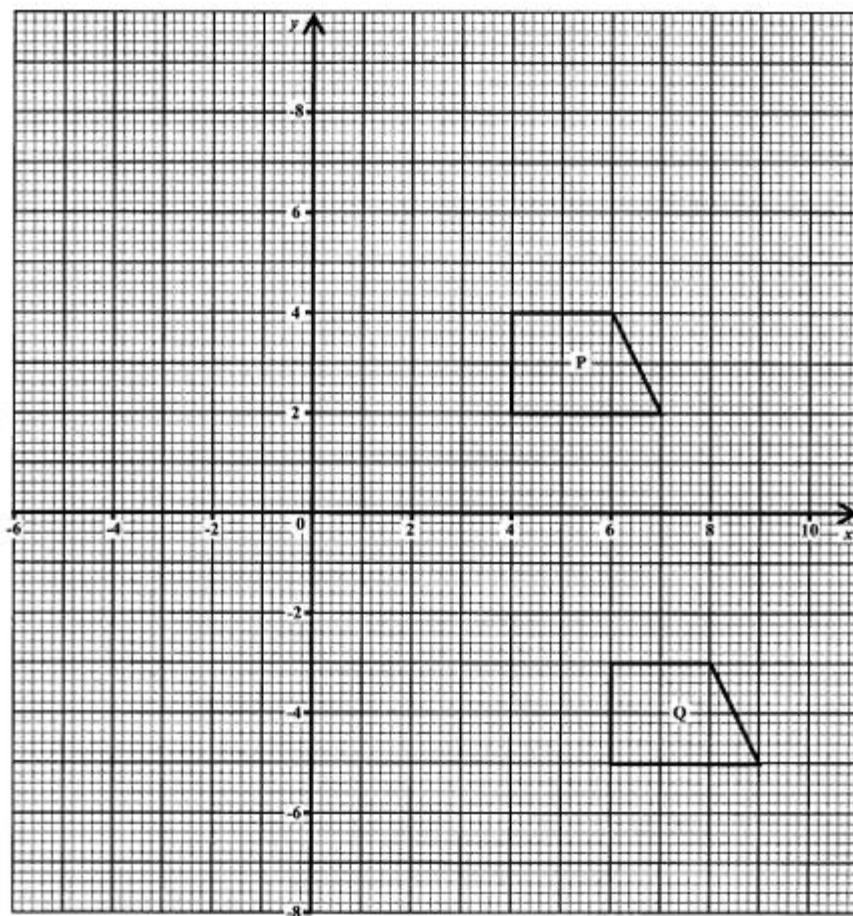

ATTACH THIS ANSWER SHEET TO YOUR ANSWER BOOKLET

01234020/F 2008

FORM TP 2008098

TEST CODE **01134020**

MAY/JUNE 2008

CARIBBEAN EXAMINATIONS COUNCIL

SECONDARY EDUCATION CERTIFICATE

EXAMINATION

MATHEMATICS

Paper 02 – Basic Proficiency

2 hours 40 minutes

21 MAY 2008 (a.m.)

B

INSTRUCTIONS TO CANDIDATES

1. Answer ALL questions.
2. Write your answers in the booklet provided.
3. All working must be shown clearly.
4. A list of formulae is provided on page 2 of this booklet.

Examination Materials

Electronic calculator (non-programmable)

Geometry set

Mathematical tables (provided)

Graph paper (provided)

DO NOT TURN THIS PAGE UNTIL YOU ARE TOLD TO DO SO

Copyright © 2006 Caribbean Examinations Council®.
All rights reserved.

01134020/F 2008

LIST OF FORMULAE

Volume of a prism $V = Ah$ where A is the area of a cross-section and h is the perpendicular length.

Volume of a right pyramid $V = \frac{1}{3}Ah$ where A is the area of the base and h is the perpendicular height.

Circumference $C = 2\pi r$ where r is the radius of the circle.

Area of a circle $A = \pi r^2$ where r is the radius of the circle.

Area of trapezium $A = \frac{1}{2}(a + b)h$ where a and b are the lengths of the parallel sides and h is the perpendicular distance between the parallel sides.

Roots of quadratic equations If $ax^2 + bx + c = 0$,
then $x = \frac{-b \pm \sqrt{b^2 - 4ac}}{2a}$

Trigonometric ratios $\sin \theta = \frac{\text{opposite side}}{\text{hypotenuse}}$

$\cos \theta = \frac{\text{adjacent side}}{\text{hypotenuse}}$

$\tan \theta = \frac{\text{opposite side}}{\text{adjacent side}}$

Area of triangle Area of $\Delta = \frac{1}{2}bh$ where b is the length of the base and h is the perpendicular height

Area of sector Area = $\frac{a}{360} \times \pi r^2$

where a is measured in degrees.

Length of Arc Arc length = $\frac{a}{360} \times 2\pi r$

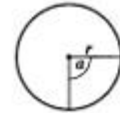
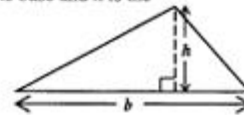
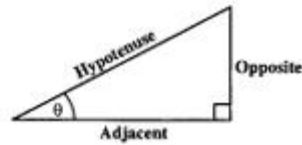
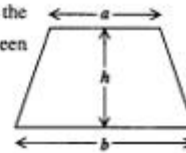
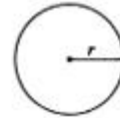

GO ON TO THE NEXT PAGE

SECTION 1

All working must be clearly shown.

1. (a) Calculate the EXACT value of

$$1\frac{1}{3} - \left(\frac{5}{8} + 1\frac{1}{4}\right)$$

giving the answer as a common fraction in its LOWEST terms. (4 marks)

- (b) The students and teachers of James Academy went on a tour in three buses, A, B and C. The table below shows the number of teachers and students in each bus.

	Teachers	Students
Bus A	6	50
Bus B	<input type="text"/>	65
Bus C	8	61

- (i) The ratio of teachers to students on Bus B was 2:13. How many teachers were on Bus B? (2 marks)
- (ii) What is the TOTAL number of passengers (teachers and students) who went on the tour? (1 mark)
- (iii) What percentage of the passengers on the tour were students? (3 marks)

Total 10 marks

2. (a) If
- $a = 4$
- ,
- $b = 5$
- and
- $c = -2$
- , calculate the value of:

(i) $2b + c$ (3 marks)

(ii) $\frac{c^2}{a}$ (2 marks)

- (b) Simplify the expression

$3(4y + 1) - 5y.$ (2 marks)

- (c) Solve the inequality

$2x + 15 \geq 7x.$ (3 marks)

Total 10 marks

GO ON TO THE NEXT PAGE

3. In the diagram below, a camera is advertised for a cash price of \$510.



- (a) The camera can be bought on hire purchase by paying a deposit of \$100 followed by 24 monthly payments of \$22.50.
- (i) Calculate the TOTAL amount paid if the camera is bought on hire purchase. (3 marks)
 - (ii) Calculate the EXTRA amount paid when buying on hire purchase compared with the cash price. (1 mark)
- (b) Dario started a bank account with a deposit of \$90. He deposited \$25 a month for 6 months.
- (i) Calculate the TOTAL amount deposited at the end of 6 months. (2 marks)
- The bank pays simple interest half-yearly at a rate of 4% per annum.
- (ii) Calculate the amount in the bank AFTER the interest was added. (4 marks)

Total 10 marks

4. (a) Solve the simultaneous equations:

$$x + 2y = 10$$

$$3x + y = 15$$

(5 marks)

- (b) Dwight is p years old. Sue is 3 years older than Dwight. Joan is twice as old as Sue.

Write an expression in terms of p for:

(i) Sue's age (1 mark)

(ii) Joan's age (1 mark)

(iii) The sum of the ages of Dwight, Sue and Joan (1 mark)

The sum of their ages is 37 years.

(iv) Write an equation in terms of p to represent this statement and solve it to determine Dwight's age. (2 marks)

Total 10 marks

5. (a) Mrs Blake is paid a weekly wage of \$248. During a certain week she worked 5 hours overtime. Her total wages were \$285.50.

Calculate

(i) her overtime wages (2 marks)

(ii) the overtime rate of pay. (2 marks)

- (b) A tourist had US currency made up of

2 one-hundred dollars

6 fifty dollars

4 twenty dollars

3 ten dollars

(i) Calculate the TOTAL value of the US currency. (2 marks)

The tourist changed all her money into EC currency.

The exchange rate of the bank is US \$1.00 = EC \$2.70. The bank also charges 2% on all exchange transactions.

(ii) Calculate the value of EC currency the tourist received AFTER the bank charges were deducted. (4 marks)

Total 10 marks

GO ON TO THE NEXT PAGE

6. (a) (i) Using only a pencil, a ruler and a pair of compasses, construct triangle WXY , in which $WX = 7$ cm, $WY = 5$ cm and the angle XWY is 90° . (4 marks)
- (ii) Measure and write down the length of the side XY . (1 mark)
- (b) The figure below, **not drawn to scale**, shows a ladder leaning against a vertical wall. The ladder is 3.6 metres long and the foot of the ladder is 2.4 metres away from the wall.

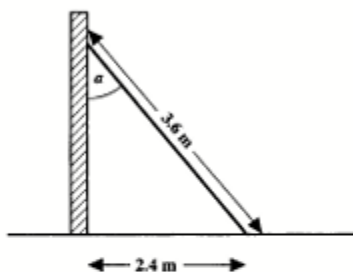

Calculate, to 2 significant figures

- (i) the height, in metres, that the ladder reaches up the wall (2 marks)
- (ii) the measure of the angle, a , that the ladder makes with the wall. (3 marks)

Total 10 marks

7. (a) Bird City and Flower Circle are two parks which are 20 km apart. These parks are drawn on a map using a scale of 1:500 000.

Calculate, in cm, the distance on the map between the two parks. (3 marks)

- (b) The figure below, **not drawn to scale**, shows a quadrilateral $JKLM$. Angle $MJK = 90^\circ$, $JM = 6.0$ cm, $JK = 4.5$ cm and $KL = 3.5$ cm.

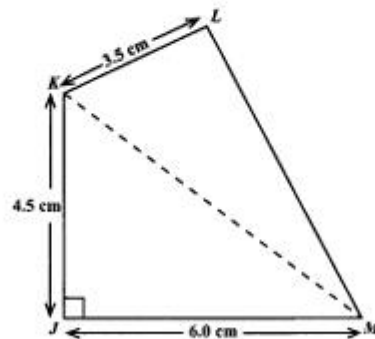

- (i) Calculate the area, in cm^2 , of triangle MJK . (2 marks)

The area of the quadrilateral is 26.26 cm^2 .

- (ii) Calculate the area, in cm^2 , of triangle KLM . (2 marks)

The perimeter of the quadrilateral is 21.5 cm.

- (iii) Calculate the length, in cm, of LM . (3 marks)

Total 10 marks

8. An answer sheet is provided for this question.

- (a) The answer sheet shows triangle PQR and its image $P'Q'R'$ after a transformation.
- (i) Write down the coordinates of P , Q and R . (1 mark)
- (ii) Describe FULLY the transformation which maps PQR to $P'Q'R'$. (3 marks)

- (b) Triangle $P''Q''R''$ (not drawn) is an enlargement of triangle $P'Q'R'$ with centre of enlargement $C(0,1)$ and scale factor 2.

On the answer sheet provided:

- (i) Label the centre of enlargement $C(0,2)$. (1 mark)
- (ii) Draw and label the triangle $P''Q''R''$, the image of $P'Q'R'$ after the enlargement. (3 marks)
- (c) Copy and complete the statement below:
- Area of $\Delta P'Q'R'$ = _____ square centimetres
- Area of $\Delta P''Q''R''$ = _____ square centimetres (2 marks)

Total 10 marks

9. An answer sheet is provided for this question.

- (a) The answer sheet shows the line, l , which passes through the points $A(-1, -2)$ and $B(2, 4)$.
- (i) Determine the gradient of the line, l . (2 marks)
- (ii) Write down the equation of the line, l . (1 mark)
- (b) (i) Given that $f(x) = 3 - x^2$, copy and complete the table below for $-3 \leq x \leq 2$.

x	-3	-2	-1	0	1	2
$f(x)$	-6		2			-1

(2 marks)

- (ii) On the answer sheet provided and using the same scale and axes, draw the graph of $f(x) = 3 - x^2$ for $-3 \leq x \leq 2$. (3 marks)
- (iii) Write down the coordinates of the points where the line, l , and the graph $f(x) = 3 - x^2$ intersect. (2 marks)

Total 10 marks

GO ON TO THE NEXT PAGE

10. (a) Rohan's mean score in three cricket matches was 55 runs.
- (i) How many runs did he score altogether? (1 mark)
- After four matches his mean score was 61 runs.
- (ii) How many runs did he score in the fourth match? (2 marks)
- (b) The pie chart below, **not drawn to scale**, shows the Saturday morning activities of a group of 120 children.



- (i) The sector for soccer is represented by an angle of 150° . Determine the number of children who play soccer on Saturday mornings. (3 marks)
- (ii) Given that 46 children swim on Saturday mornings, calculate the value of x . (2 marks)
- (iii) Determine the probability that a child chosen at random, dances on Saturday mornings. (2 marks)

Total 10 marks

END OF TEST

FORM TP 2008098

TEST CODE 01134020

MAY/JUNE 2008

CARIBBEAN EXAMINATIONS COUNCIL

SECONDARY EDUCATION CERTIFICATE

EXAMINATION

MATHEMATICS

Paper 02 – Basic Proficiency

Answer Sheet for Question 8

Candidate Number

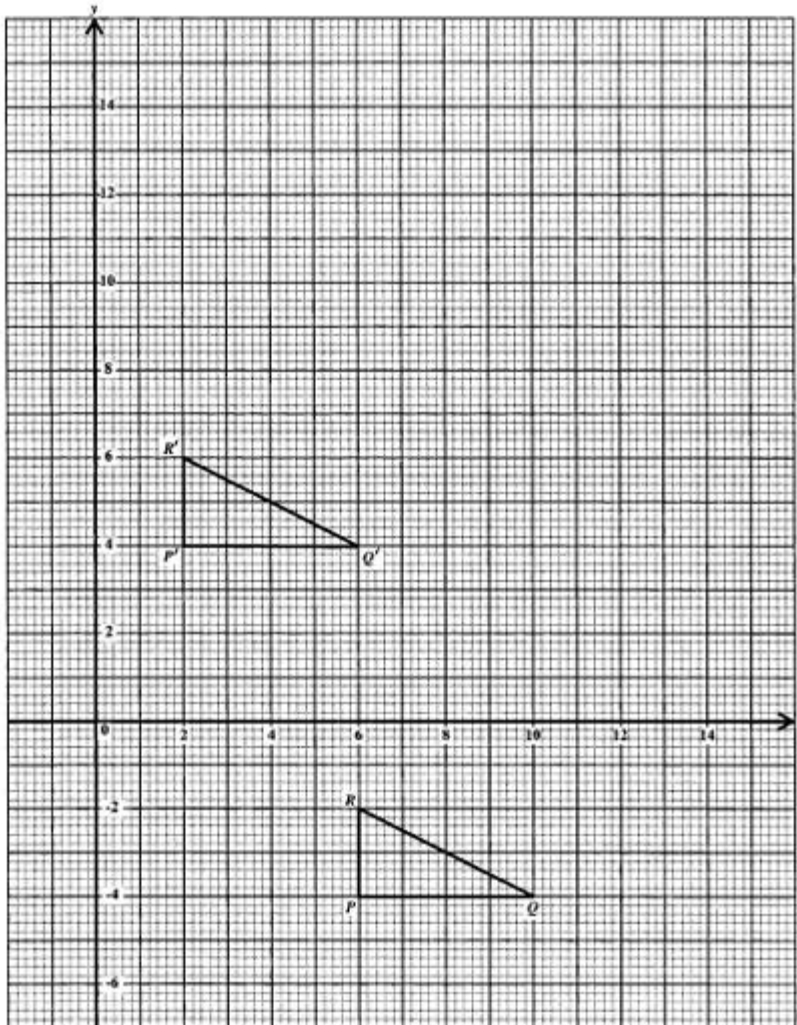

ATTACH THIS ANSWER SHEET TO YOUR ANSWER BOOKLET

01134020/F 2008

FORM TP 2008098

TEST CODE **01134020**

MAY/JUNE 2008

CARIBBEAN EXAMINATIONS COUNCIL

SECONDARY EDUCATION CERTIFICATE

EXAMINATION

MATHEMATICS

Paper 02 – Basic Proficiency

Answer Sheet for Question 9

Candidate Number

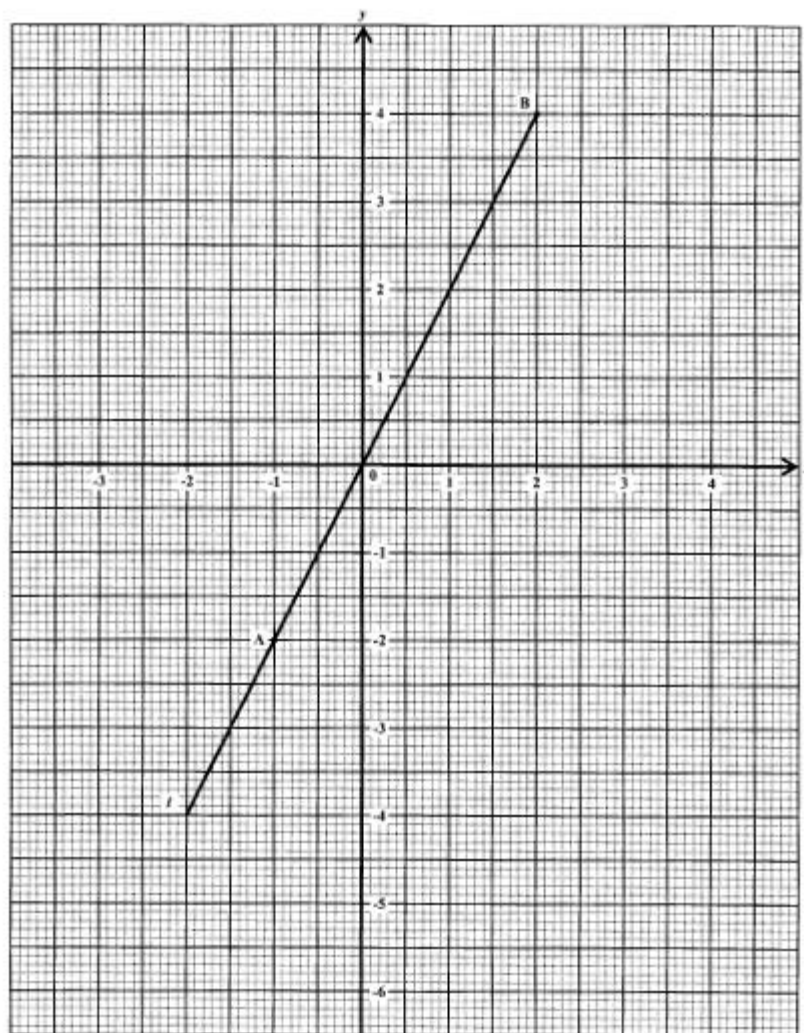

ATTACH THIS ANSWER SHEET TO YOUR ANSWER BOOKLET

01134020/F 2008

C A R I B B E A N E X A M I N A T I O N S C O U N C I L

SECONDARY EDUCATION CERTIFICATE
EXAMINATION

SPECIMEN
MULTIPLE CHOICE QUESTIONS
FOR

MATHEMATICS

Basic & General Proficiencies

READ THE FOLLOWING DIRECTIONS CAREFULLY

Each item in this test has four suggested answers lettered (A), (B), (C), (D). Read each item you are about to answer and decide which choice is best.

Sample Item

$$2a + 6a =$$

- (A) $8a$
- (B) $8a^2$
- (C) $12a$
- (D) $12a^2$

Sample Answer



The best answer to this item is "8a", so answer space (A) has been shaded.

There are 30 items in this specimen paper. However, the Paper 01 test consists of 60 items.

Copyright © 2008 Caribbean Examinations Council.
All rights reserved.

LIST OF FORMULAE

Volume of a prism	$V = Ah$ where A is the area of a cross-section and h is the perpendicular length.
Volume of cylinder	$V = \pi r^2 h$ where r is the radius of the base and h is the perpendicular height.
Volume of a right pyramid	$V = \frac{1}{3}Ah$ where A is the area of the base and h is the perpendicular height.
Circumference	$C = 2\pi r$ where r is the radius of the circle.
Area of a circle	$A = \pi r^2$ where r is the radius of the circle.
Area of trapezium	$A = \frac{1}{2}(a + b)h$ where a and b are the lengths of the parallel sides and h is the perpendicular distance between the parallel sides.

Roots of quadratic equations If $ax^2 + bx + c = 0$,
 then $x = \frac{-b \pm \sqrt{b^2 - 4ac}}{2a}$

Trigonometric ratios
 $\sin \theta = \frac{\text{opposite side}}{\text{hypotenuse}}$
 $\cos \theta = \frac{\text{adjacent side}}{\text{hypotenuse}}$
 $\tan \theta = \frac{\text{opposite side}}{\text{adjacent side}}$

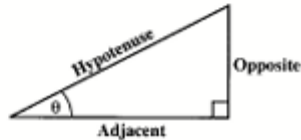

Area of triangle Area of $\Delta = \frac{1}{2}bh$ where b is the length of the base and h is the perpendicular height

$$\text{Area of } \Delta ABC = \frac{1}{2}ab \sin C$$



$$\text{Area of } \Delta ABC = \sqrt{s(s-a)(s-b)(s-c)}$$

$$\text{where } s = \frac{a+b+c}{2}$$

Sine rule $\frac{a}{\sin A} = \frac{b}{\sin B} = \frac{c}{\sin C}$

Cosine rule $a^2 = b^2 + c^2 - 2bc \cos A$

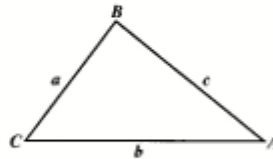

GO ON TO THE NEXT PAGE

1. The number 2 747 written to 3 significant figures is

(A) 2740
(B) 2750
(C) 274
(D) 275

2. The number 3754 expressed to the nearest hundred is

(A) 3700
(B) 3750
(C) 3800
(D) 4000

3. 0.045×10^{-3} in scientific notation is

(A) 4.5×10^{-6}
(B) 4.5×10^{-5}
(C) 4.5×10^{-4}
(D) 4.5×10^{-3}

4. $(0.1 + 0.01)(0.1 - 0.01) =$

(A) 0.0001
(B) 0.001
(C) 0.009
(D) 0.0099

5. What is the value of $\frac{(5+2)^3}{5^2 - 2^2}$ in its simplest form?

(A) $\frac{8}{21}$
(B) $\frac{7}{3}$
(C) $\frac{7}{2}$
(D) $\frac{45}{3}$

6. Which of the following sets has an infinite number of members?

(A) {factors of 20}
(B) {multiples of 20}
(C) {odd numbers between 10 and 20}
(D) {prime numbers less than 20}

Item 7 refers to the diagram below.

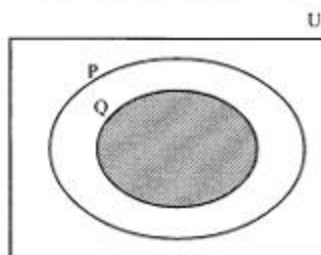

7. The shaded area in the Venn diagram above represents

(A) P'
(B) Q'
(C) $P \cup Q$
(D) $P \cap Q$

8. How much simple interest is due on a loan of \$1 200 for two years if the annual rate of interest is $5\frac{1}{2}$ per cent?

(A) \$120.00
(B) \$132.00
(C) \$264.00
(D) \$330.00

Item 9 refers to the chart shown below.

Rate on Fixed Deposits	
2008	7.8%
2009	7.5%

9. How much more interest would a fixed deposit of \$10 000 earn in 2008 than in 2009?
- (A) \$ 0.30
(B) \$ 3.00
(C) \$30.00
(D) \$33.00
10. Consumption tax and customs duty are calculated as follows:
- | | |
|-----------------|--------------|
| Consumption tax | 20% of value |
| Custom's duty | 50% of value |
- What is the total tax paid on an article which is valued at \$150.00?
- (A) \$ 45.00
(B) \$ 90.00
(C) \$105.00
(D) \$120.00
11. The water authority charges \$10.00 per month for the meter rent, \$25.00 for the first 100 litres and \$1.00 for each additional 10 litres. What is the total bill for 250 litres used in one month?
- (A) \$25.00
(B) \$35.00
(C) \$40.00
(D) \$50.00
12. Seven times the product of two numbers, a and b , may be written as
- (A) $7ab$
(B) $7a + b$
(C) $7a + 7b$
(D) $49ab$
13. If $2(x - 1) - 3x = 6$, then $x =$
- (A) - 8
(B) - 4
(C) 4
(D) 8
14. $3m^2n^3 \times 4mn^2 =$
- (A) $7m^3n^5$
(B) $12m^3n^5$
(C) $12m^2n^5$
(D) $7m^2n^5$
15. $\frac{3x+1}{2} - \frac{x+1}{4} =$
- (A) $\frac{5x+1}{4}$
(B) $\frac{5x+3}{4}$
(C) $\frac{7x+3}{4}$
(D) $\frac{7x+1}{4}$
16. How many litres of water would a container whose volume is 36 cm^3 hold?
- (A) 0.036
(B) 0.36
(C) 36
(D) 3600

17. The width of a block of wood with rectangular cross-section is x cm. Its height is $\frac{2}{3}$ its width and its length is 4 times its height. What is its volume in cm^3 ?
- (A) $\frac{8x}{9}$
 (B) $\frac{8x^2}{3}$
 (C) $\frac{16x^3}{9}$
 (D) $\frac{17x}{3}$
20. The mean of ten numbers is 58. If one of the numbers is 40, what is the mean of the other nine?
- (A) 18
 (B) 60
 (C) 162
 (D) 540

Item 18 refers to the following trapezium.

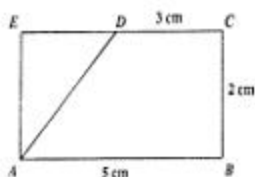

18. $ABCD$ is a trapezium and ADE is a triangle. Angles B , C and E are right angles.
- The area of the trapezium $ABCD$ is
- (A) 8 cm^2
 (B) 16 cm^2
 (C) 30 cm^2
 (D) 32 cm^2
19. A circular hole with diameter 6 cm is cut out of a circular piece of card with a diameter of 12 cm. The area of the remaining card, in cm^2 , is
- (A) 6π
 (B) 27π
 (C) 36π
 (D) 108π
21. What is the probability that a child chosen at random is AT LEAST 13 years old?
- (A) $\frac{4}{25}$
 (B) $\frac{9}{25}$
 (C) $\frac{14}{25}$
 (D) $\frac{16}{25}$
22. What is the mode of this distribution?
- (A) 4
 (B) 6
 (C) 11
 (D) 16

Items 21 - 22 refer to the table below which shows the distribution of the ages of 25 children in a choir.

Age	11	12	13	14	15	16
No. of children	6	3	5	4	4	3

23. The equation of the line which passes through the point $(0, 2)$ and has a gradient of $\frac{1}{3}$ is

- (A) $y = 3x$
 (B) $y = 3x + 2$
 (C) $y = \frac{1}{3}x$
 (D) $y = \frac{1}{3}x + 2$

24. If g is a function such that $g(x) = 2x + 1$, which of the following pairs satisfies the function?

- (A) $(-3, -5)$
 (B) $(-6, 11)$
 (C) $(5, 2)$
 (D) $(13, 6)$

25. What is the gradient of a line which passes through the points $(-4, 3)$ and $(-2, 5)$?

- (A) -4
 (B) $-\frac{1}{3}$
 (C) $\frac{1}{3}$
 (D) 1

26. The sizes of the interior angles of a polygon are x° , $2x^\circ$, 60° , $3x^\circ$ and 36° . What is the value of x ?

- (A) 14
 (B) 16
 (C) 44
 (D) 74

Item 27 refers to the diagram below.

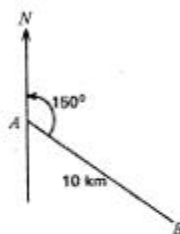

27. A plane travels from point A on a bearing 150° to a point B 10 km from A . How far east of A is B ?

- (A) $10 \cos 30^\circ$
 (B) $10 \cos 60^\circ$
 (C) $10 \sin 60^\circ$
 (D) $10 \tan 30^\circ$

Item 28 refers to the diagram below.

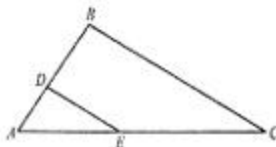

28. Triangle ABC is an enlargement of triangle ADE such that

$$\frac{AD}{DB} = \frac{AE}{EC} = \frac{1}{2}$$

If the area $ABC = 36 \text{ cm}^2$

Then the area of $DECB$ in cm^2 is

- (A) 18
 (B) 24
 (C) 27
 (D) 32

29. The point $P(2, -3)$ is rotated about the origin through an angle of 90° in an anti-clockwise direction. What are the coordinates of the image P' ?

- (A) $(3, 2)$
- (B) $(2, 3)$
- (C) $(-3, 2)$
- (D) $(3, -2)$

Item 30 refers to the triangle PQR , in which angle $QPR = 90^\circ$, $PR = 12$ cm and $PQ = 5$ cm.

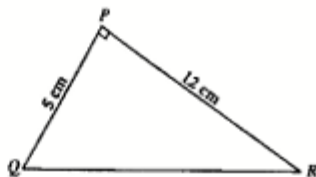

30. The length of QR , in cm, is

- (A) 7
- (B) 11
- (C) 13
- (D) 17

IF YOU FINISH BEFORE TIME IS CALLED, CHECK YOUR WORK ON THIS TEST.

C A R I B B E A N E X A M I N A T I O N S C O U N C I L

SECONDARY EDUCATION CERTIFICATE
EXAMINATION

SPECIMEN
MULTIPLE CHOICE QUESTIONS
FOR

MATHEMATICS

Basic & General Proficiencies

READ THE FOLLOWING DIRECTIONS CAREFULLY

Each item in this test has four suggested answers lettered (A), (B), (C), (D). Read each item you are about to answer and decide which choice is best.

Sample Item

$$2a + 6a =$$

- (A) $8a$
- (B) $8a^2$
- (C) $12a$
- (D) $12a^2$

Sample Answer



The best answer to this item is "8a", so answer space (A) has been shaded.

There are 30 items in this specimen paper. However, the Paper 01 test consists of 60 items.

Copyright © 2008 Caribbean Examinations Council.
All rights reserved.

LIST OF FORMULAE

Volume of a prism	$V = Ah$ where A is the area of a cross-section and h is the perpendicular length.
Volume of cylinder	$V = \pi r^2 h$ where r is the radius of the base and h is the perpendicular height.
Volume of a right pyramid	$V = \frac{1}{3}Ah$ where A is the area of the base and h is the perpendicular height.
Circumference	$C = 2\pi r$ where r is the radius of the circle.
Area of a circle	$A = \pi r^2$ where r is the radius of the circle.
Area of trapezium	$A = \frac{1}{2}(a + b)h$ where a and b are the lengths of the parallel sides and h is the perpendicular distance between the parallel sides.

Roots of quadratic equations If $ax^2 + bx + c = 0$,

$$\text{then } x = \frac{-b \pm \sqrt{b^2 - 4ac}}{2a}$$

Trigonometric ratios

$$\sin \theta = \frac{\text{opposite side}}{\text{hypotenuse}}$$

$$\cos \theta = \frac{\text{adjacent side}}{\text{hypotenuse}}$$

$$\tan \theta = \frac{\text{opposite side}}{\text{adjacent side}}$$

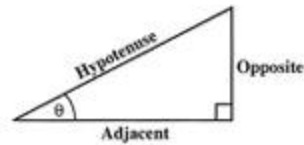

Area of triangle

Area of $\Delta = \frac{1}{2}bh$ where b is the length of the base and h is the perpendicular height

$$\text{Area of } \Delta ABC = \frac{1}{2}ab \sin C$$

$$\text{Area of } \Delta ABC = \sqrt{s(s-a)(s-b)(s-c)}$$

$$\text{where } s = \frac{a+b+c}{2}$$

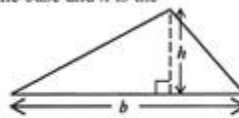

Sine rule

$$\frac{a}{\sin A} = \frac{b}{\sin B} = \frac{c}{\sin C}$$

Cosine rule

$$a^2 = b^2 + c^2 - 2bc \cos A$$

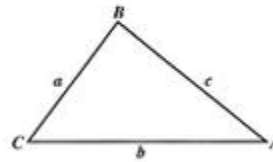

GO ON TO THE NEXT PAGE

1. The number 2 747 written to 3 significant figures is
- (A) 2 740
(B) 2 750
(C) 2 74
(D) 2 75
6. Which of the following sets has an infinite number of members?
- (A) {factors of 20}
(B) {multiples of 20}
(C) {odd numbers between 10 and 20}
(D) {prime numbers less than 20}

2. The number 3 754 expressed to the nearest hundred is

- (A) 3 700
(B) 3 750
(C) 3 800
(D) 4 000

3. 0.045×10^{-3} in scientific notation is

- (A) 4.5×10^{-6}
(B) 4.5×10^{-5}
(C) 4.5×10^{-4}
(D) 4.5×10^{-3}

4. $(0.1 + 0.01)(0.1 - 0.01) =$

- (A) 0.0001
(B) 0.001
(C) 0.009
(D) 0.0099

5. What is the value of $\frac{(5+2)^3}{5^2 \cdot 2^2}$ in its simplest form?

- (A) $\frac{8}{21}$
(B) $\frac{7}{3}$
(C) $\frac{7}{2}$
(D) $\frac{45}{3}$

Item 7 refers to the diagram below.

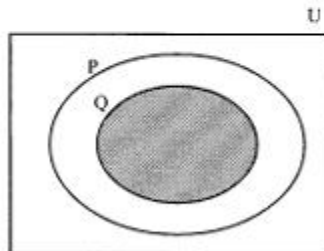

7. The shaded area in the Venn diagram above represents

- (A) P'
(B) Q'
(C) $P \cup Q$
(D) $P \cap Q$

8. How much simple interest is due on a loan of \$1 200 for two years if the annual rate of interest is $5\frac{1}{2}$ per cent?

- (A) \$120.00
(B) \$132.00
(C) \$264.00
(D) \$330.00

Item 9 refers to the chart shown below.

Rate on Fixed Deposits	
2008	7.8%
2009	7.5%

9. How much more interest would a fixed deposit of \$10 000 earn in 2008 than in 2009?
- (A) \$ 0.30
(B) \$ 3.00
(C) \$30.00
(D) \$33.00
10. Consumption tax and customs duty are calculated as follows:
- | | |
|-----------------|--------------|
| Consumption tax | 20% of value |
| Custom's duty | 50% of value |
- What is the total tax paid on an article which is valued at \$150.00?
- (A) \$ 45.00
(B) \$ 90.00
(C) \$105.00
(D) \$120.00
11. The water authority charges \$10.00 per month for the meter rent, \$25.00 for the first 100 litres and \$1.00 for each additional 10 litres. What is the total bill for 250 litres used in one month?
- (A) \$25.00
(B) \$35.00
(C) \$40.00
(D) \$50.00
12. Seven times the product of two numbers, a and b , may be written as
- (A) $7ab$
(B) $7a + b$
(C) $7a + 7b$
(D) $49ab$
13. If $2(x - 1) - 3x = 6$, then $x =$
- (A) - 8
(B) - 4
(C) 4
(D) 8
14. $3m^2n^3 \times 4mn^2 =$
- (A) $7m^3n^5$
(B) $12m^3n^5$
(C) $12m^2n^5$
(D) $7m^2n^5$
15. $\frac{3x+1}{2} - \frac{x+1}{4} =$
- (A) $\frac{5x+1}{4}$
(B) $\frac{5x+3}{4}$
(C) $\frac{7x+3}{4}$
(D) $\frac{7x+1}{4}$
16. How many litres of water would a container whose volume is 36 cm^3 hold?
- (A) 0.036
(B) 0.36
(C) 36
(D) 3600

17. The width of a block of wood with rectangular cross-section is x cm. Its height is $\frac{2}{3}$ its width and its length is 4 times its height. What is its volume in cm^3 ?
- (A) $\frac{8x}{9}$
 (B) $\frac{8x^2}{3}$
 (C) $\frac{16x^2}{9}$
 (D) $\frac{17x}{3}$
20. The mean of ten numbers is 58. If one of the numbers is 40, what is the mean of the other nine?
- (A) 18
 (B) 60
 (C) 162
 (D) 540

Items 21 - 22 refer to the table below which shows the distribution of the ages of 25 children in a choir.

Age	11	12	13	14	15	16
No. of children	6	3	5	4	4	3

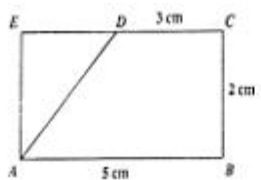
- Item 18 refers to the following trapezium.
- 
18. $ABCD$ is a trapezium and ADE is a triangle. Angles B , C and E are right angles. The area of the trapezium $ABCD$ is
- (A) 8 cm^2
 (B) 16 cm^2
 (C) 30 cm^2
 (D) 32 cm^2
19. A circular hole with diameter 6 cm is cut out of a circular piece of card with a diameter of 12 cm. The area of the remaining card, in cm^2 , is
- (A) 6π
 (B) 27π
 (C) 36π
 (D) 108π
21. What is the probability that a child chosen at random is AT LEAST 13 years old?
- (A) $\frac{4}{25}$
 (B) $\frac{9}{25}$
 (C) $\frac{14}{25}$
 (D) $\frac{16}{25}$
22. What is the mode of this distribution?
- (A) 4
 (B) 6
 (C) 11
 (D) 16

23. The equation of the line which passes through the point $(0, 2)$ and has a gradient of $\frac{1}{3}$ is

- (A) $y = 3x$
 (B) $y = 3x + 2$
 (C) $y = \frac{1}{3}x$
 (D) $y = \frac{1}{3}x + 2$

24. If g is a function such that $g(x) = 2x + 1$, which of the following pairs satisfies the function?

- (A) $(-3, -5)$
 (B) $(-6, 11)$
 (C) $(5, 2)$
 (D) $(13, 6)$

25. What is the gradient of a line which passes through the points $(-4, 3)$ and $(-2, 5)$?

- (A) -4
 (B) $-\frac{1}{3}$
 (C) $\frac{1}{3}$
 (D) 1

26. The sizes of the interior angles of a polygon are x° , $2x^\circ$, 60° , $3x^\circ$ and 36° . What is the value of x ?

- (A) 14
 (B) 16
 (C) 44
 (D) 74

Item 27 refers to the diagram below.

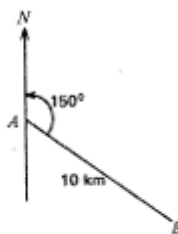

27. A plane travels from point A on a bearing 150° to a point B 10 km from A . How far east of A is B ?

- (A) $10 \cos 30^\circ$
 (B) $10 \cos 60^\circ$
 (C) $10 \sin 60^\circ$
 (D) $10 \tan 30^\circ$

Item 28 refers to the diagram below.



28. Triangle ABC is an enlargement of triangle ADE such that

$$\frac{AD}{DB} = \frac{AE}{EC} = \frac{1}{2}$$

If the area $ABC = 36 \text{ cm}^2$

Then the area of $DECB$ in cm^2 is

- (A) 18
 (B) 24
 (C) 27
 (D) 32

29. The point $P(2, -3)$ is rotated about the origin through an angle of 90° in an anti-clockwise direction. What are the coordinates of the image P' ?

- (A) $(3, 2)$
- (B) $(2, 3)$
- (C) $(-3, 2)$
- (D) $(3, -2)$

Item 30 refers to the triangle PQR , in which angle $QPR = 90^\circ$, $PR = 12$ cm and $PQ = 5$ cm.

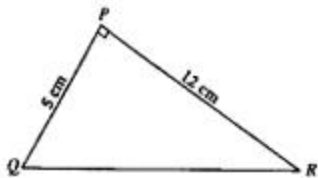

30. The length of QR , in cm, is

- (A) 7
- (B) 11
- (C) 13
- (D) 17

IF YOU FINISH BEFORE TIME IS CALLED, CHECK YOUR WORK ON THIS TEST.

FORM TP 2009015

TEST CODE **01234020**

JANUARY 2009

**CARIBBEAN EXAMINATIONS COUNCIL
SECONDARY EDUCATION CERTIFICATE
EXAMINATION
MATHEMATICS**

Paper 02 – General Proficiency

2 hours 40 minutes

06 JANUARY 2009 (a.m.)

INSTRUCTIONS TO CANDIDATES

1. Answer ALL questions in Section I, and ANY TWO in Section II.
2. Write your answers in the booklet provided.
3. All working must be shown clearly.
4. A list of formulae is provided on page 2 of this booklet.

Examination Materials

Electronic calculator (non-programmable)
Geometry set
Graph paper (provided)

DO NOT TURN THIS PAGE UNTIL YOU ARE TOLD TO DO SO

Copyright © 2007 Caribbean Examinations Council®
All rights reserved.

01234020/JANUARY/F 2009

LIST OF FORMULAE

Volume of a prism	$V = Ah$ where A is the area of a cross-section and h is the perpendicular length.
Volume of cylinder	$V = \pi r^2 h$ where r is the radius of the base and h is the perpendicular height.
Volume of a right pyramid	$V = \frac{1}{3} Ah$ where A is the area of the base and h is the perpendicular height.
Circumference	$C = 2\pi r$ where r is the radius of the circle.
Area of a circle	$A = \pi r^2$ where r is the radius of the circle.
Area of trapezium	$A = \frac{1}{2} (a + b) h$ where a and b are the lengths of the parallel sides and h is the perpendicular distance between the parallel sides.

Roots of quadratic equations If $ax^2 + bx + c = 0$,
 then $x = \frac{-b \pm \sqrt{b^2 - 4ac}}{2a}$

Trigonometric ratios

$$\sin \theta = \frac{\text{opposite side}}{\text{hypotenuse}}$$

$$\cos \theta = \frac{\text{adjacent side}}{\text{hypotenuse}}$$

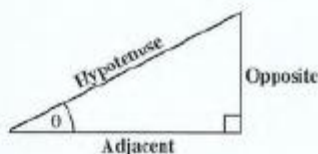
$$\tan \theta = \frac{\text{opposite side}}{\text{adjacent side}}$$

Area of triangle Area of $\Delta = \frac{1}{2} bh$ where b is the length of the base and h is the perpendicular height

$$\text{Area of } \Delta ABC = \frac{1}{2} ab \sin C$$

$$\text{Area of } \Delta ABC = \sqrt{s(s-a)(s-b)(s-c)}$$

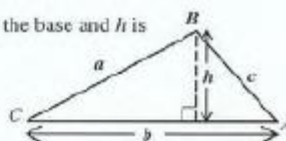

$$\text{where } s = \frac{a + b + c}{2}$$

Sine rule

$$\frac{a}{\sin A} = \frac{b}{\sin B} = \frac{c}{\sin C}$$

Cosine rule

$$a^2 = b^2 + c^2 - 2bc \cos A$$

GO ON TO THE NEXT PAGE

SECTION I

Answer ALL the questions in this section.

All working must be clearly shown.

1. (a) Calculate the EXACT value of

$$\frac{3\frac{3}{4}}{2\frac{1}{3} - \frac{5}{6}}$$

giving your answer as a fraction.

(3 marks)

- (b) BDS\$ means Barbados dollars and EC\$ means Eastern Caribbean dollars.

- (i) Karen exchanged BDS\$2 000.00 and received EC\$2 700.00. Calculate the value of one BDS\$ in EC\$. (2 marks)
- (ii) If Karen exchanged EC\$432.00 for BDS\$, calculate the amount of BDS\$ which Karen would receive. (2 marks)

[Assume that the buying and selling rates are the same.]

- (c) A credit union pays 8% per annum compound interest on all fixed deposits. A customer deposited \$24 000 in an account. Calculate the TOTAL amount of money in the account at the end of two years. (4 marks)

Total 11 marks

2. (a) Simplify, expressing your answer as a single fraction

$$\frac{\frac{2m}{n} - \frac{5m}{3n}}{\quad}$$

(3 marks)

- (b) If $a * b = a^2 - b$, evaluate $5 * 2$.

(1 mark)

- (c) Factorize completely $3x - 6y + x^2 - 2xy$.

(2 marks)

- (d) A drinking straw of length 21 cm is cut into 3 pieces. The length of the first piece is x cm. The second piece is 3 cm shorter than the first piece. The third piece is twice as long as the first piece.

- (i) State, in terms of x , the length of EACH of the pieces. (2 marks)
- (ii) Write an **expression**, in terms of x , to represent the sum of the lengths of the three pieces of drinking straw. (1 mark)
- (iii) **Hence**, calculate the value of x . (3 marks)

Total 12 marks

GO ON TO THE NEXT PAGE

3. (a) A school has 90 students in Form 5.
54 students study Physical Education.
42 students study Music.
6 students study neither Physical Education nor Music.
 x students study both Physical Education and Music.

(i) Copy the Venn diagram shown below.

(1 mark)

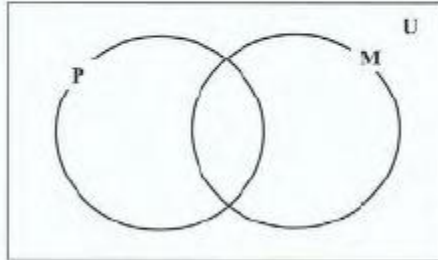

- (ii) Show on your Venn diagram the information relating to the students in Form 5.
(2 marks)
- (iii) Calculate the number of students who study BOTH Physical Education and Music.
(2 marks)

- (b) The diagram below, **not drawn to scale**, shows two straight wires, LJ and NK , supporting a vertical pole, MJ . LMN is a straight line on the horizontal plane. Angle $JML = 90^\circ$, angle $KNM = 30^\circ$, $LJ = 13$ m, $LM = 5$ m and $KN = 10$ m.

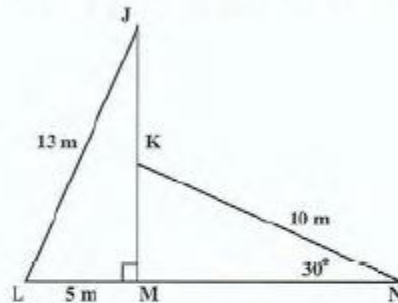

Calculate, in metres, the length of

- (i) MK (3 marks)
- (ii) JK . (3 marks)

Total 12 marks

4. The diagram below represents the graph of a straight line which passes through the points P and Q .

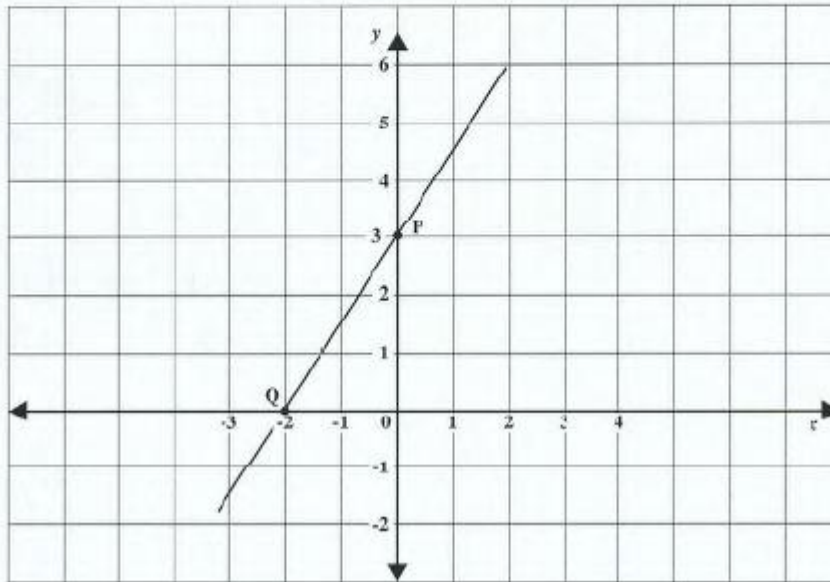

- (a) State the coordinates of P and Q . (2 marks)
- (b) Determine
- the gradient of the line segment PQ (2 marks)
 - the equation of the line segment PQ . (2 marks)
- (c) The point $(-8, t)$ lies on the line segment PQ . Determine the value of t . (2 marks)
- The line segment, AB , is perpendicular to PQ , and passes through $(6, 2)$.
- (d) Determine the equation of AB in the form $y = mx + c$. (3 marks)

Total 11 marks

5. A company makes cereal boxes in the shape of a right prism.

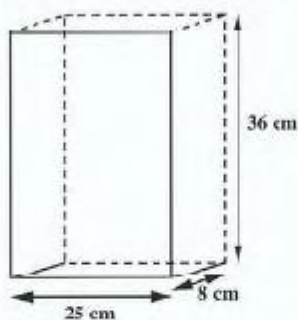

EACH large box has dimensions 25 cm by 8 cm by 36 cm.

- (a) Calculate the volume in cubic centimetres, of ONE large cereal box. (2 marks)
- (b) Calculate the total surface area of ONE large cereal box. (4 marks)
- (c) The cereal from ONE large box can exactly fill six small boxes, each of equal volume.
- (i) Calculate the volume of ONE small cereal box. (2 marks)
- (ii) If the height of a small box is 20 cm, list TWO different pairs of values which the company can use for the length and width of a small box. (2 marks)

Total 10 marks

6. (a) The diagram below, **not drawn to scale**, shows rectangle PQRS with $PQ = 7.0$ cm and $QR = 5.5$ cm.

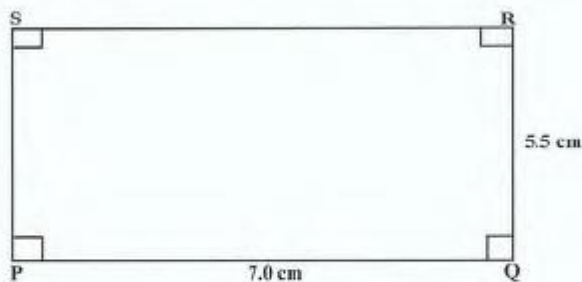

Using a ruler, a pencil and a pair of compasses only, construct the rectangle.

(6 marks)

GO ON TO THE NEXT PAGE

An answer sheet is provided for this question.

(b) The diagram below shows three triangles labelled L , M and N .

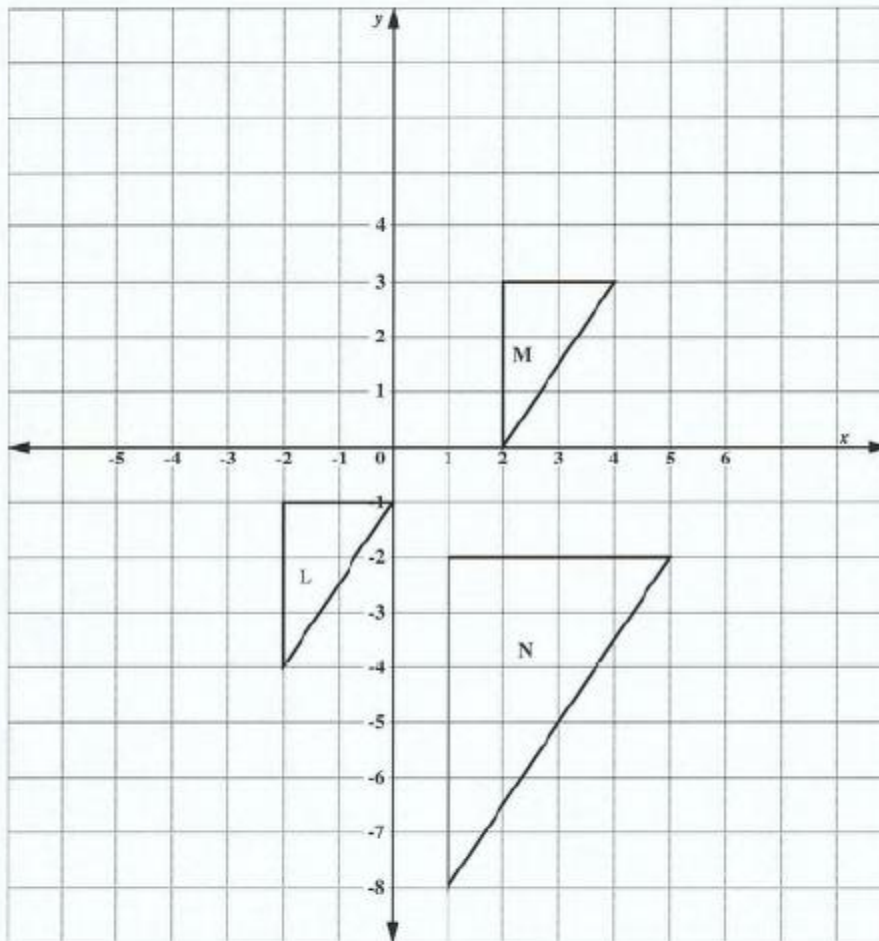

L is mapped onto M by t translation.

- (i) State, in the form $\begin{pmatrix} x \\ y \end{pmatrix}$, the vector which represents the translation.

(2 marks)

(ii) L is mapped onto N by an enlargement:

- a) Find and label **on your answer sheet** the point G , the centre of the enlargement. **Show your method clearly.**
- b) State the coordinates of G .
- c) State the scale factor of the enlargement. (4 marks)

Total 12 marks

7. The table below shows the distribution of marks on a test for a group of 70 students.

Mark	Frequency	Cumulative Frequency
1 – 10	2	2
11 – 20	5	7
21 – 30	9	16
31 – 40	14	
41 – 50	16	
51 – 60	12	
61 – 70	8	
71 – 80	4	70

- (a) Copy and complete the table to show the cumulative frequency for the distribution.
(2 marks)
- (b) (i) Using a scale of 1 cm to represent 5 marks on the horizontal axis and 1 cm to represent 5 students on the vertical axis, draw the cumulative frequency curve for the scores.
(5 marks)
- (ii) What assumption have you made in drawing your curve through the point (0,0)?
(1 mark)
- (c) The pass mark for the test is 47. Use your graph to determine the number of students who passed the test.
(2 marks)
- (d) What is the probability that a student chosen at random had a mark less than or equal to 30?
(2 marks)

Total 12 marks

8. An answer sheet is provided for this question.

The figure below shows the first three diagrams in a sequence. Each diagram is made up of dots connected by line segments. In each diagram, there are d dots and l line segments.

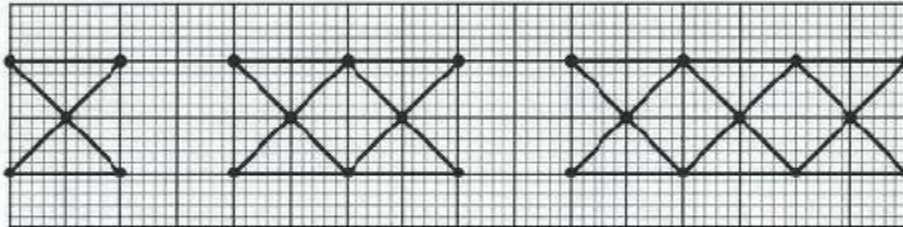

On the answer sheet provided:

- (a) Draw the fourth diagram in the sequence. (2marks)
- (b) Complete the table by inserting the missing values at the rows marked (i) and (ii).

No. of dots d	Pattern connecting l and d	No. of line segments l
5	$2 \times 5 - 4$	6
8	$2 \times 8 - 4$	12
11	$2 \times 11 - 4$	18
(i) 62	()	()
(ii) ()	()	180

- (2 marks)
- (2 marks)
- (c) (i) How many dots are in the sixth diagram of the sequence? (1 mark)
- (ii) How many line segments are in the seventh diagram of the sequence? (1 mark)
- (iii) Write the rule which shows how l is related to d . (2 marks)

Total 10 marks

SECTION II

Answer TWO questions in this section.

ALGEBRA AND RELATIONS, FUNCTIONS AND GRAPHS

9. (a) Make
- t
- the subject of the formula

$$\frac{p}{2} = \sqrt{\frac{t+r}{g}} \quad (3 \text{ marks})$$

- (b) (i) Express the function
- $f(x) = 2x^2 - 4x - 13$
- in the form
- $f(x) = a(x+h)^2 - k$
- .
-
- (3 marks)

Hence, or otherwise, determine

- (ii) the values of x at which the graph cuts the x -axis (4 marks)
- (iii) the interval for which $f(x) < 0$ (2 marks)
- (iv) the minimum value of $f(x)$ (1 mark)
- (v) the value of x at which $f(x)$ is a minimum. (2 marks)

Total 15 marks

10. (a) Two functions are defined as follows:

$$f: x \rightarrow x - 3$$

$$g: x \rightarrow x^2 - 1$$

- (i) Calculate $f(6)$. (1 mark)
- (ii) Find $f^{-1}(x)$. (1 mark)
- (iii) Show that $f \circ g(2) = f \circ g(-2) = 0$. (3 marks)

- (b) An answer sheet is provided for this question.

The distance-time graph below describes the journey of a train between two train stations, A and B. Answer the questions below **on the answer sheet**.

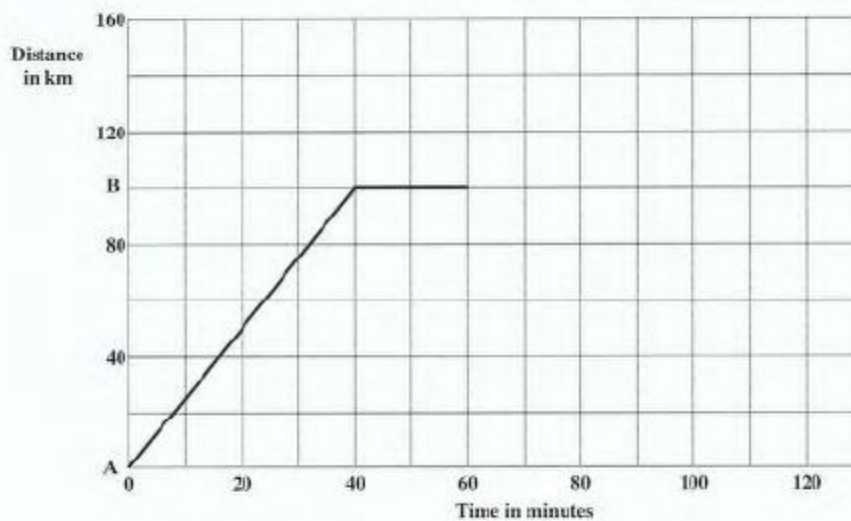

- (i) For how many minutes was the train at rest at B? (1 mark)
- (ii) Determine the average speed of the train, in km/h, on its journey from A to B. (2 marks)

The train continued its journey away from stations A and B to another station C, which is 50 km from B. The average speed on this journey was 60 km/h.

- (iii) Calculate the time, in minutes, taken for the train to travel from B to C. (2 marks)
- (iv) **On your answer sheet**, draw the line segment which describes the journey of the train from B to C. (3 marks)

Total 15 marks

GO ON TO THE NEXT PAGE

GEOMETRY AND TRIGONOMETRY

11. (a) (i) Copy and complete the table for the graph of

$$y = \frac{1}{2} \tan x, \text{ for } 10^\circ \leq x \leq 60^\circ.$$

x	10°	20°	30°	40°	50°	60°
y	0.13		0.29		0.60	0.87

(1 mark)

- (ii) Using a scale of 2 cm to represent 10° (10 degrees) on the horizontal axis and 10 cm to represent 1 unit on the vertical axis, plot the values from the table and draw a smooth curve through your points. (4 marks)

- (iii) Use your graph to estimate the value of x when $y = 0.7$. (1 mark)

- (b) The diagram below, **not drawn to scale**, shows a circle with centre, O . EA and EB are tangents to the circle, and angle $AEB = 48^\circ$.

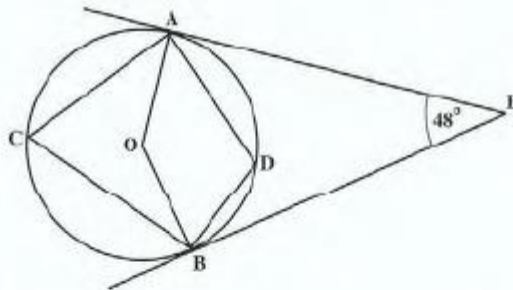

Calculate, giving reasons for your answer, the size of EACH of the following angles:

- (i) $\angle OAE$ (2 marks)
 (ii) $\angle AOB$ (3 marks)
 (iii) $\angle ACB$ (2 marks)
 (iv) $\angle ADB$ (2 marks)

Total 15 marks

GO ON TO THE NEXT PAGE

12. (a) On the diagram below, **not drawn to scale**. $TU = 8$ m, $TW = 10$ m, $VW = 11$ m, angle $UTW = 60^\circ$ and angle $WUV = 40^\circ$.

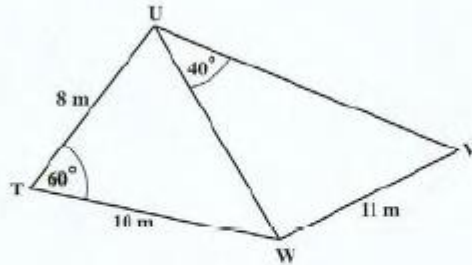

Calculate

- (i) the length of UW (2 marks)
- (ii) the size of the angle UVW (2 marks)
- (iii) the area of triangle TUW (2 marks)

In this question use $\pi = \frac{22}{7}$, and assume that the earth is a sphere of radius 6 370 km.

- (b) The diagram below, **not drawn to scale**, represents the surface of the earth. The points N and S represent the North and South Poles respectively. The Equator and Greenwich Meridian are labelled. The following are also shown on the diagram but they are not labelled:

- circles of latitude 30°N and 20°S
- circle of longitude 40°E .

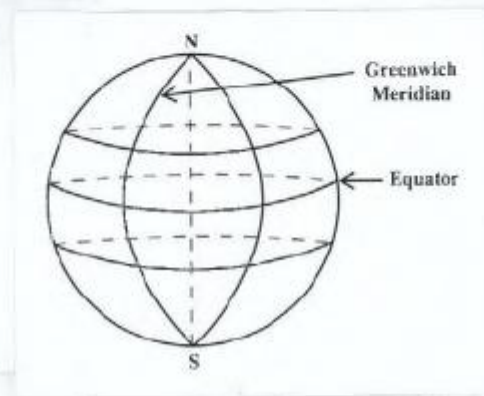

- (i) Copy the diagram and label it to show
- a) circles of latitude 30°N and 20°S
 - b) circle of longitude 40°E
 - c) the point P (30°N , 40°E). (5 marks)
- (ii) The position of the point Q is 20°S and 40°E .
Calculate, **correct to 3 significant figures**,
- a) the **SHORTEST** distance from P to Q measured along the common circle of longitude (2 marks)
 - b) the radius of the circle of latitude on which Q lies. (2 marks)

Total 15 marks

VECTORS AND MATRICES

13. The diagram below shows position vectors \vec{OP} and \vec{OQ} .

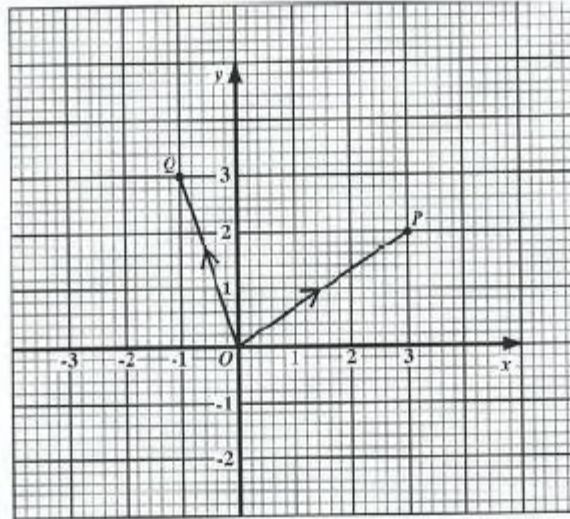

- (a) Write as a column vector, in the form $\begin{pmatrix} x \\ y \end{pmatrix}$
- (i) \vec{OP} (1 mark)
- (ii) \vec{OQ} (1 mark)
- (b) The point R has coordinates $(8, 9)$.
- (i) Express \vec{QR} as a vector in the form $\begin{pmatrix} x \\ y \end{pmatrix}$. (2 marks)
- (ii) Using a vector method, show that \vec{OP} is parallel to \vec{QR} . (1 mark)
- (iii) Determine the magnitude of the vector \vec{PR} . (2 marks)
- (c) The point S has coordinates (a, b) .
- (i) Write \vec{QS} as a column vector, in terms of a and b . (2 marks)
- (ii) Given that $\vec{QS} = \vec{OP}$, calculate the value of a and the value of b . (3 marks)
- (iii) Using a vector method, show that $OPSQ$ is a parallelogram. (3 marks)

Total 15 marks

GO ON TO THE NEXT PAGE

14. (a) Calculate the matrix product $3AB$, where $A = \begin{pmatrix} 1 & 2 \\ 2 & 1 \end{pmatrix}$ and $B = \begin{pmatrix} 1 & 3 \\ 2 & 5 \end{pmatrix}$.
(3 marks)
- (b) The diagram below, **not drawn to scale**, shows a triangle, ABC whose coordinates are stated.

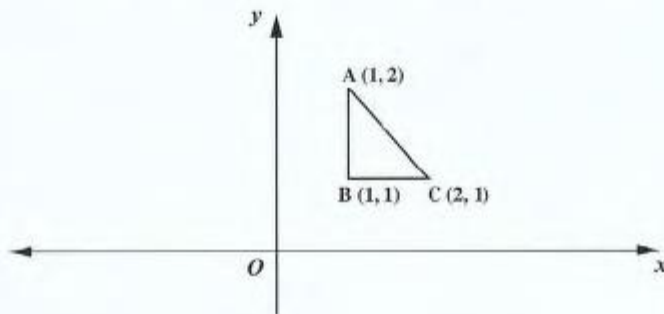

Triangle ABC undergoes two successive transformations, V followed by W , where

$$V = \begin{pmatrix} 2 & 0 \\ 0 & 2 \end{pmatrix} \text{ and } W = \begin{pmatrix} -1 & 0 \\ 0 & 1 \end{pmatrix}.$$

- (i) State the effect of V on triangle ABC . (2 marks)
- (ii) Determine the 2×2 matrix that represents the combined transformation of V followed by W . (3 marks)
- (iii) Using your matrix in (b) (ii), determine the coordinates of the image of triangle ABC under this combined transformation. (3 marks)
- (c) (i) Write the following simultaneous equations in the form $AX = B$ where A , X and B are matrices:
- $$\begin{aligned} 11x + 6y &= 6 \\ 9x + 5y &= 7 \end{aligned} \quad (2 \text{ marks})$$
- (ii) **Hence**, write the solution for x and y as a product of two matrices. (2 marks)

Total 15 marks

END OF TEST

TEST CODE **01234020**

FORM TP 2009015

JANUARY 2009

CARIBBEAN EXAMINATIONS COUNCIL
SECONDARY EDUCATION CERTIFICATE
EXAMINATION
MATHEMATICS

Paper 02 – General Proficiency

Answer Sheet for Question 6 (b)

Candidate Number

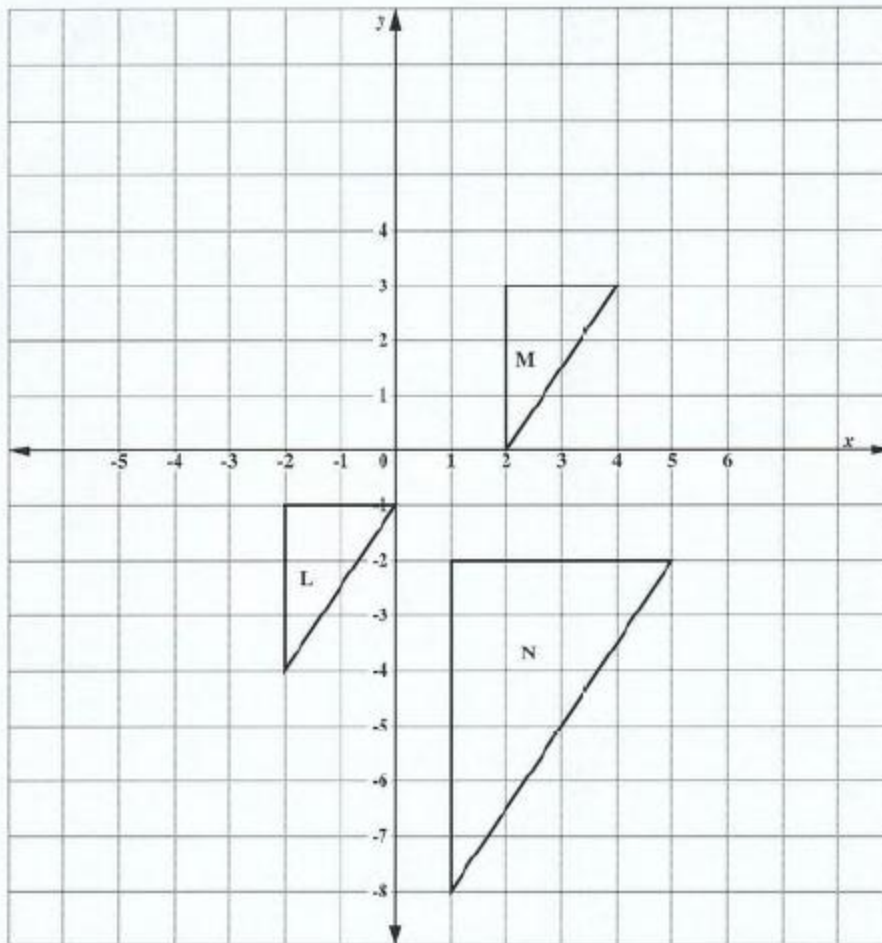

ATTACH THIS ANSWER SHEET TO YOUR ANSWER BOOKLET

01234020/JANUARY/F 2009

TEST CODE **01234020**

JANUARY 2009

FORM TP 2009015

**CARIBBEAN EXAMINATIONS COUNCIL
SECONDARY EDUCATION CERTIFICATE
EXAMINATION
MATHEMATICS**

Paper 02 – General Proficiency

Answer Sheet for Question 8

Candidate Number

(a)

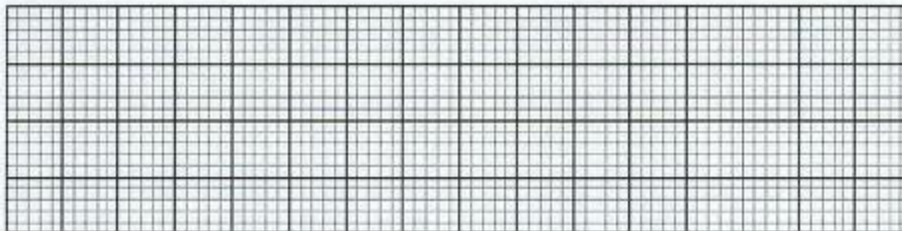

(b)

No. of dots <i>d</i>	Pattern connecting <i>l</i> and <i>d</i>	No. of line segments <i>l</i>
5	$2 \times 5 - 4$	6
8	$2 \times 8 - 4$	12
11	$2 \times 11 - 4$	18
(i) 62	()	()
(ii) ()	()	180

- (c) (i) _____
(ii) _____
(iii) _____

ATTACH THIS ANSWER SHEET TO YOUR ANSWER BOOKLET

01234020/JANUARY/F 2009

TEST CODE **01234020**

FORM TP 2009015

JANUARY 2009

**CARIBBEAN EXAMINATIONS COUNCIL
SECONDARY EDUCATION CERTIFICATE
EXAMINATION
MATHEMATICS**

Paper 02 – General Proficiency

Answer Sheet for Question 10 (b)

Candidate Number

(i) _____

(ii) _____

(iii) _____

(iv)

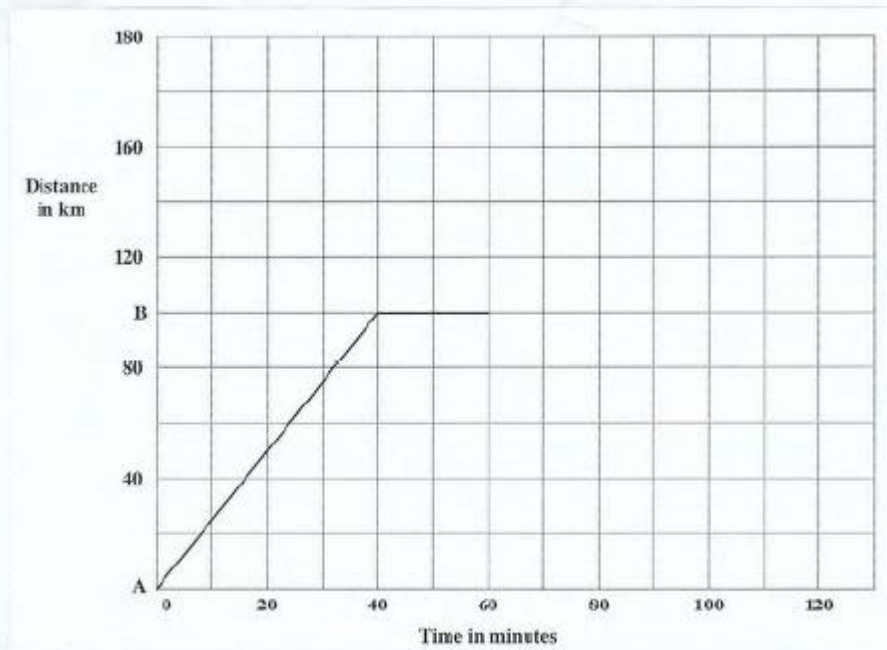

ATTACH THIS ANSWER SHEET TO YOUR ANSWER BOOKLET

FORM TP 2009092

TEST CODE **01234020**

MAY/JUNE 2009

CARIBBEAN EXAMINATIONS COUNCIL

**SECONDARY EDUCATION CERTIFICATE
EXAMINATION**

MATHEMATICS

Paper 02 – General Proficiency

2 hours 40 minutes

20 MAY 2009 (a.m.)

INSTRUCTIONS TO CANDIDATES

1. Answer ALL questions in Section I, and ANYTWO in Section II.
2. Write your answers in the booklet provided.
3. All working must be shown clearly.
4. A list of formulae is provided on page 2 of this booklet.

Examination Materials

Electronic calculator (non-programmable)
Geometry set
Mathematical tables
Graph paper (provided)

DO NOT TURN THIS PAGE UNTIL YOU ARE TOLD TO DO SO.

Copyright © 2007 Caribbean Examinations Council®.
All rights reserved.

01234020/F 2009

LIST OF FORMULAE

Volume of a prism $V = Ah$ where A is the area of a cross-section and h is the perpendicular length.

Volume of cylinder $V = \pi r^2 h$ where r is the radius of the base and h is the perpendicular height.

Volume of a right pyramid $V = \frac{1}{3}Ah$ where A is the area of the base and h is the perpendicular height.

Circumference $C = 2\pi r$ where r is the radius of the circle.

Area of a circle $A = \pi r^2$ where r is the radius of the circle.

Area of trapezium $A = \frac{1}{2}(a + b)h$ where a and b are the lengths of the parallel sides and h is the perpendicular distance between the parallel sides.

Roots of quadratic equations If $ax^2 + bx + c = 0$,
then $x = \frac{-b \pm \sqrt{b^2 - 4ac}}{2a}$

Trigonometric ratios $\sin \theta = \frac{\text{opposite side}}{\text{hypotenuse}}$

$$\cos \theta = \frac{\text{adjacent side}}{\text{hypotenuse}}$$

$$\tan \theta = \frac{\text{opposite side}}{\text{adjacent side}}$$

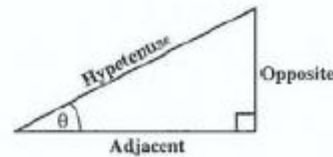

Area of triangle Area of $\Delta = \frac{1}{2}bh$ where b is the length of the base and h is the perpendicular height

$$\text{Area of } \Delta ABC = \frac{1}{2}ab \sin C$$

$$\text{Area of } \Delta ABC = \sqrt{s(s-a)(s-b)(s-c)}$$

$$\text{where } s = \frac{a + b + c}{2}$$

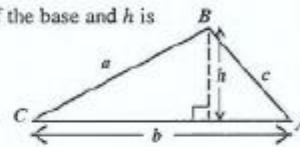

Sine rule $\frac{a}{\sin A} = \frac{b}{\sin B} = \frac{c}{\sin C}$

Cosine rule $a^2 = b^2 + c^2 - 2bc \cos A$

GO ON TO THE NEXT PAGE

SECTION I

Answer ALL the questions in this section.

All working must be clearly shown.

1. (a) Using a calculator, or otherwise, calculate the EXACT value of

$$(i) \frac{2\frac{2}{3} + 1\frac{1}{5}}{6\frac{2}{3}}$$

giving your answer as a common fraction

(3 marks)

$$(ii) \sqrt{\left(\frac{0.0256}{25}\right)}$$

giving your answer in standard form.

(3 marks)

- (b) The basic wage earned by a truck driver for a 40-hour week is \$560.00.

(i) Calculate his hourly rate.

(1 mark)

For overtime work, the driver is paid one and a half times the basic hourly rate.

(ii) Calculate his overtime wage for 10 hours of overtime.

(2 marks)

(iii) Calculate the TOTAL wages earned by the truck driver for a 55-hour week.

(3 marks)

Total 12 marks

2. (a) Factorise completely

(i) $2ax + 3ay - 2bx - 3by$

(2 marks)

(ii) $5x^2 - 20$

(2 marks)

(iii) $3x^2 + 4x - 15$

(2 marks)

- (b) One packet of biscuits costs \$x and one cup of ice cream costs \$y.

One packet of biscuits and two cups of ice cream cost \$8.00, while three packets of biscuits and one cup of ice cream cost \$9.00.

(i) Write a pair of simultaneous equations in x and y to represent the given information above.

(2 marks)

(ii) Solve the equations obtained in (b) (i) above to find the cost of one packet of biscuits and the cost of one cup of ice cream.

(4 marks)

Total 12 marks

GO ON TO THE NEXT PAGE

3. (a) In a survey of 50 students,
 23 owned cellular phones
 18 owned digital cameras
 x owned cellular phones and digital cameras
 $2x$ owned neither.

Let C represent the set of students in the survey who owned cellular phones, and D the set of students who owned digital cameras.

- (i) Copy and complete the Venn diagram below to represent the information obtained from the survey.

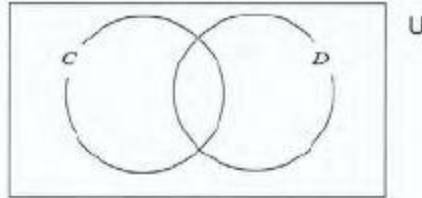

(2 marks)

- (ii) Write an expression in x for the TOTAL number of students in the survey. (1 mark)
 (iii) Calculate the value of x . (2 marks)

- (b) The diagram below, **not drawn to scale**, shows a rhombus $PQRS$, with the diagonal $PR = 6$ cm, and the angle $RPQ = 60^\circ$.

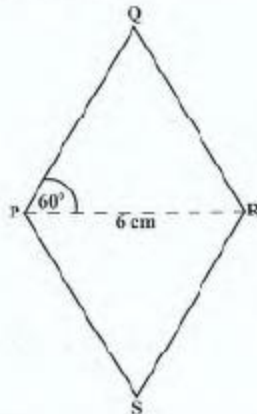

- (i) Using a ruler, a pencil, and a pair of compasses, construct the rhombus $PQRS$ accurately. (4 marks)
 (ii) Join QS . Measure and state, in centimetres, the length of QS . (2 marks)

Total 11 marks

GO ON TO THE NEXT PAGE

4. (a) The table below shows two readings taken from an aircraft's flight record.

Time	Distance Travelled (km)
08:55	957
09:07	1083

For the period of time between the two readings, calculate

- (i) the distance travelled in kilometres (1 mark)
- (ii) the average speed of the aircraft in km/h. (3 marks)
- (b) The map shown below is drawn to a scale of 1:50 000.

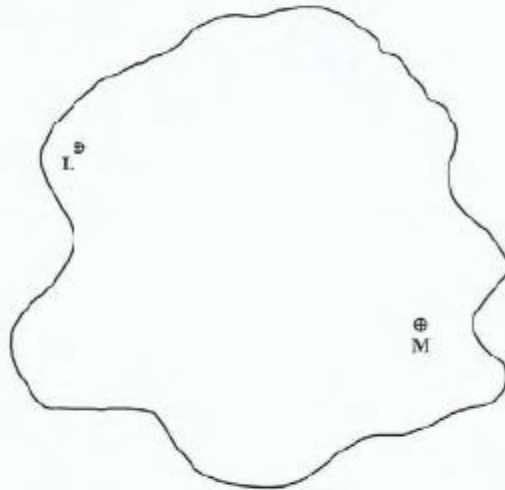

- (i) Measure and state, in centimetres, the distance on the map from L to M along a straight line. (2 marks)
- (ii) Calculate the actual distance, in kilometres, from L to M . (2 marks)
- (iii) The actual distance between two points is 4.5 km. Calculate the number of centimetres that should be used to represent this distance on the map. (3 marks)

Total 11 marks

GO ON TO THE NEXT PAGE

5. (a) Given that $f(x) = 2x - 5$ and $g(x) = x^2 - 31$, calculate the value of
- (i) $f(-2)$ (1 mark)
 - (ii) $g^f(1)$ (2 marks)
 - (iii) $f^{-1}(3)$. (2 marks)

- (b) Given that $y = x^2 + 2x - 3$

- (i) Copy and complete the table below.

x	-4	-3	-2	-1	0	1	2
y	5		-3	-4	-3		5

(2 marks)

- (ii) Using a scale of **2 cm to represent 1 unit on the x-axis** and **1 cm to represent 1 unit on the y-axis**, draw the graph of $y = x^2 + 2x - 3$ for $-4 \leq x \leq 2$.
(5 marks)

Total 12 marks

6. The diagram below shows triangles A , B and D . The line $y = x$ is also shown.

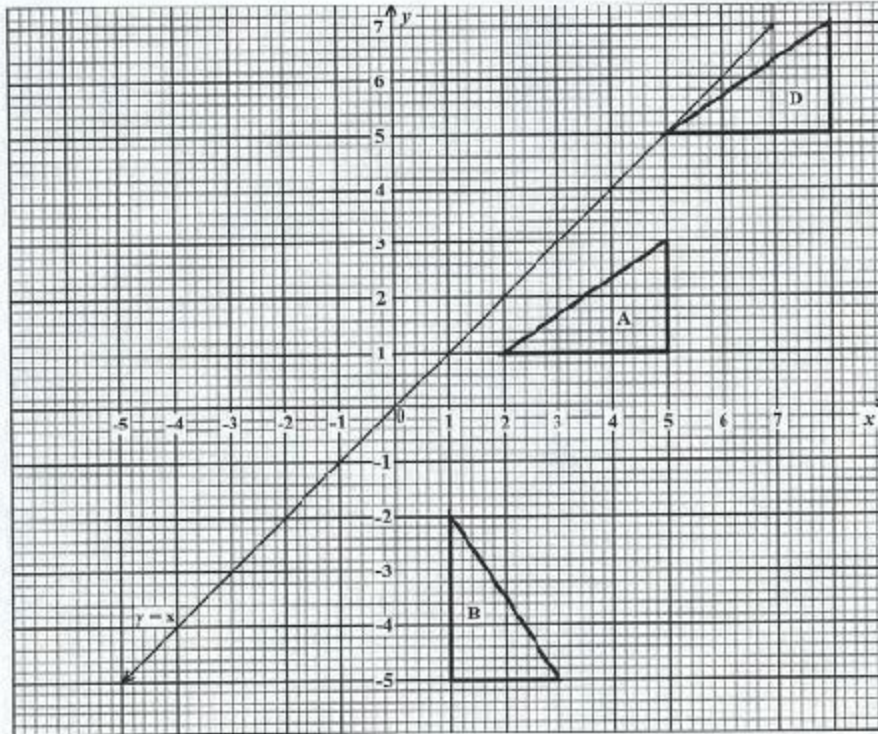

- (a) Describe, FULLY, the single transformation which maps triangle A onto
- triangle D (3 marks)
 - triangle B . (3 marks)
- (b) State the coordinates of the vertices of triangle C , the image of triangle A after a reflection in the line $y = x$. (4 marks)

Total 10 marks

7. **An answer sheet is provided for this question.**

The table below shows the time, to the nearest minute, that 80 students waited to be served at a school's canteen.

Waiting Time (minutes)	No. of Students	Cumulative Frequency
1 – 5	4	4
6 – 10	7	11
11 – 15	11	22
16 – 20	18	
21 – 25	22	
26 – 30	10	
31 – 35	5	
36 – 40	3	

- (a) Copy and complete the table, showing the cumulative frequency. (2 marks)
- (b) **On the answer sheet provided**, use the values from your table to complete the cumulative frequency curve. (4 marks)
- (c) **Use your graph from (b) above** to estimate
- the median for the data (2 marks)
 - the number of students who waited for **no more than** 29 minutes (2 marks)
 - the probability that a student, chosen at random from the group, waited for **no more than** 17 minutes. (2 marks)

Total 12 marks

8. An answer sheet is provided for this question.

The drawings below show the first three diagrams in a sequence. Each diagram in the sequence is obtained by drawing a 1-unit square on each side that forms the perimeter of the previous diagram.

For example, Diagram 2 is obtained by drawing a 1-unit square on each of the four sides of Diagram 1.

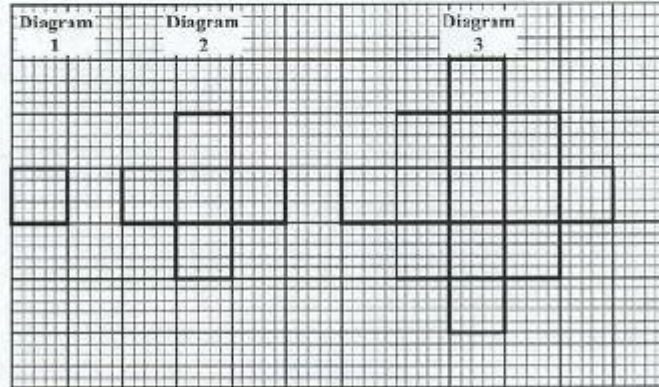

On the answer sheet provided:

- (a) Draw Diagram 4 in the sequence. (2 marks)
- (b) Complete the table by inserting the appropriate values at the rows marked (i), (ii) and (iii). (8 marks)

Total 10 marks

SECTION II

Answer TWO questions in this section.

RELATIONS, FUNCTIONS AND GRAPHS

9. (a) Solve the pair of simultaneous equations
- $$y = 4 - 2x$$
- $$y = 2x^2 - 3x + 1. \quad (4 \text{ marks})$$
- (b) Express $2x^2 - 3x + 1$ in the form $a(x + h)^2 + k$ where a , h and k are real numbers. (3 marks)
- (c) Using your answer from (b) above, or otherwise, calculate
- (i) the minimum value of $2x^2 - 3x + 1$ (1 mark)
- (ii) the value of x for which the minimum occurs. (1 mark)
- (d) Sketch the graph of $y = 2x^2 - 3x + 1$, clearly showing
- the coordinates of the minimum point
 - the value of the y -intercept
 - the values of x where the graph cuts the x -axis. (4 marks)
- (e) Sketch on your graph of $y = 2x^2 - 3x + 1$, the line which intersects the curve at the values of x and y calculated in (a) above. (2 marks)

Total 15 marks

GO ON TO THE NEXT PAGE

10. (a) The owner of a shop wishes to buy x guitars and y violins. To satisfy the demands of his customers, the number of violins must be less than or equal to the number of guitars.
- (i) Write an inequality to represent this information. (1 mark)
- The cost of one guitar is \$150 and the cost of one violin is \$300. He has \$4 500 to spend on the purchase of these instruments.
- (ii) Write an inequality to represent this information. (2 marks)
- To get a good bargain, the owner of the shop must buy at least 5 violins.
- (iii) Write an inequality to represent this information. (1 mark)
- (b) (i) Using a scale of 2 cm on the horizontal axis to represent 5 guitars, and 2 cm on the vertical axis to represent 5 violins, draw the graphs of the lines associated with the THREE inequalities written in (a) (i), (ii) and (iii) above. (4 marks)
- (ii) Shade the region on your graph that satisfies all THREE inequalities. (1 mark)
- (iii) State the coordinates of the vertices of the shaded region. (2 marks)
- (c) The owner of the shop sells the instruments to make a profit of \$60 on each guitar and \$100 on each violin.
- (i) Express the TOTAL profit in terms of x and y . (1 mark)
- (ii) Calculate the maximum profit. (3 marks)

Total 15 marks

GEOMETRY AND TRIGONOMETRY

11. (a) The diagram below, **not drawn to scale**, shows a circle, centre O . The line DCE is a tangent to the circle. Angle $ACE = 48^\circ$ and angle $OCD = 26^\circ$.

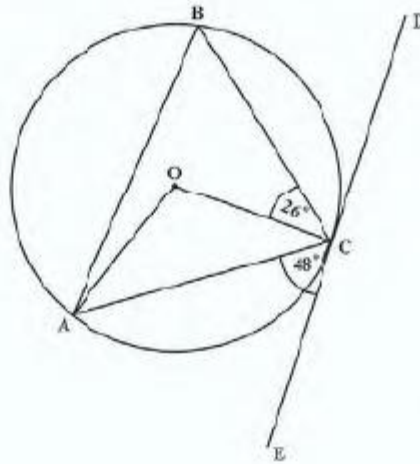

Calculate:

- | | |
|--------------------|------------|
| (i) $\angle ABC$ | (1 mark) |
| (ii) $\angle AOC$ | (1 mark) |
| (iii) $\angle BCD$ | (1 mark) |
| (iv) $\angle BAC$ | (1 mark) |
| (v) $\angle OAC$ | (1 mark) |
| (vi) $\angle OAB$ | (1 mark) |

- (b) The diagram below, **not drawn to scale**, shows the positions of two hurricane tracking stations, P and Q , relative to a point O . P is on a bearing of 025° from O , and $OP = 400$ km. Q is on a bearing of 080° from P and $PQ = 700$ km.

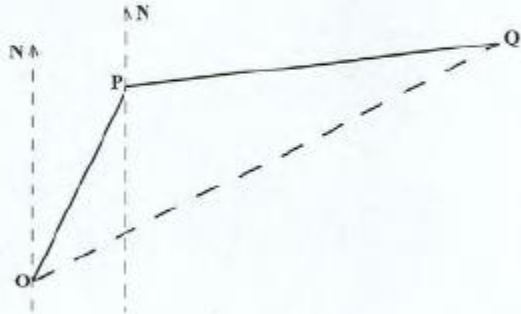

- (i) Copy the diagram above. On your diagram label the angles that show the bearings of 025° and 080° . (2 marks)
- (ii) Calculate
- $\angle OPQ$
 - the length, to the nearest kilometre, of OQ
 - the bearing of Q from O . (7 marks)

Total 15 marks

12. In this question, use $\pi = \frac{22}{7}$, and assume that the earth is a sphere of radius 6370 km.

The diagram below, **not drawn to scale**, shows a sketch of the earth with the North and South Poles labelled N and S respectively.

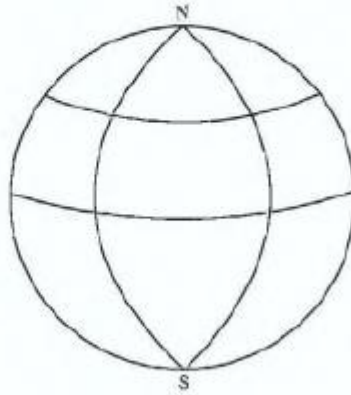

Arcs representing circles of longitude 35°E and 15°W , and circles of latitude 0° and 60°N are drawn but not labelled.

- (a) Copy the sketch and
- (i) label the arc which represents:
 - a) 60°N
 - b) 35°E (2 marks)
 - (ii) insert the points:
 - a) J (60°N , 35°E)
 - b) K (60°N , 15°W) (2 marks)
- (b) Calculate, **to the nearest kilometre**, the SHORTEST distance from
- (i) J to the North Pole measured along the common circle of longitude (3 marks)
 - (ii) J to K measured along the common circle of latitude. (4 marks)
- (c) A point H is located 2002 km due south of K along the common circle of longitude.
Calculate the latitude of H. (4 marks)

Total 15 marks

GO ON TO THE NEXT PAGE

VECTORS AND MATRICES

13. (a) The points A and B have position vectors $\vec{OA} = \begin{pmatrix} -2 \\ 5 \end{pmatrix}$ and $\vec{OB} = \begin{pmatrix} 4 \\ 2 \end{pmatrix}$ where O is the origin $(0, 0)$. The point G lies on the line AB such that $AG = \frac{1}{3}AB$.

Express in the form $\begin{pmatrix} x \\ y \end{pmatrix}$

- (i) the vectors \vec{AB} and \vec{AG} (4 marks)
- (ii) the position vector \vec{OG} . (2 marks)
- (b) In the diagram below, **not drawn to scale**, B is the midpoint of OX , C is the midpoint of AB , and D is such that $OD = 2DA$. The vectors \mathbf{a} and \mathbf{b} are such that $\vec{OA} = 3\mathbf{a}$ and $\vec{OB} = \mathbf{b}$.

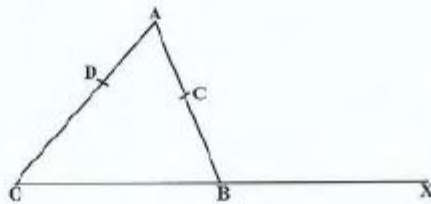

- (i) Write in terms of \mathbf{a} and \mathbf{b} :
- a) \vec{AB}
- b) \vec{AC}
- c) \vec{DC}
- d) \vec{DX} (6 marks)
- (ii) State TWO geometrical relationships between DX and DC . (2 marks)
- (iii) State ONE geometrical relationship between the points D , C , and X . (1 mark)

Total 15 marks

14. (a) The value of the determinant of $M = \begin{pmatrix} x & 4 \\ 3 & x \end{pmatrix}$ is 13.
Calculate the values of x . (4 marks)
- (b) The transformation R is represented by the matrix $\begin{pmatrix} -1 & 0 \\ 0 & 1 \end{pmatrix}$.
The transformation S is represented by the matrix $\begin{pmatrix} 0 & 1 \\ -1 & 0 \end{pmatrix}$.
- (i) Write a single matrix, in the form $\begin{pmatrix} a & b \\ c & d \end{pmatrix}$ to represent the combined transformation S followed by R . (2 marks)
- (ii) Calculate the image of the point $(5, -2)$ under the combined transformation in (b) (i) above. (3 marks)
- (c) The matrix $N = \begin{pmatrix} 3 & -1 \\ 2 & 5 \end{pmatrix}$.
- (i) Determine the inverse matrix of N . (2 marks)
- (ii) Hence, calculate the value of x and the value of y for which
- $$\begin{aligned} 3x - y &= 5 \\ 2x + 5y &= 9. \end{aligned}$$
- (4 marks)

Total 15 marks

END OF TEST

TEST CODE **01234020**

MAY/JUNE 2009

FORM TP 2009092

**CARIBBEAN EXAMINATIONS COUNCIL
SECONDARY EDUCATION CERTIFICATE
EXAMINATION
MATHEMATICS**

Paper 02 – General Proficiency

Answer Sheet for Question 7 (b)

Candidate Number

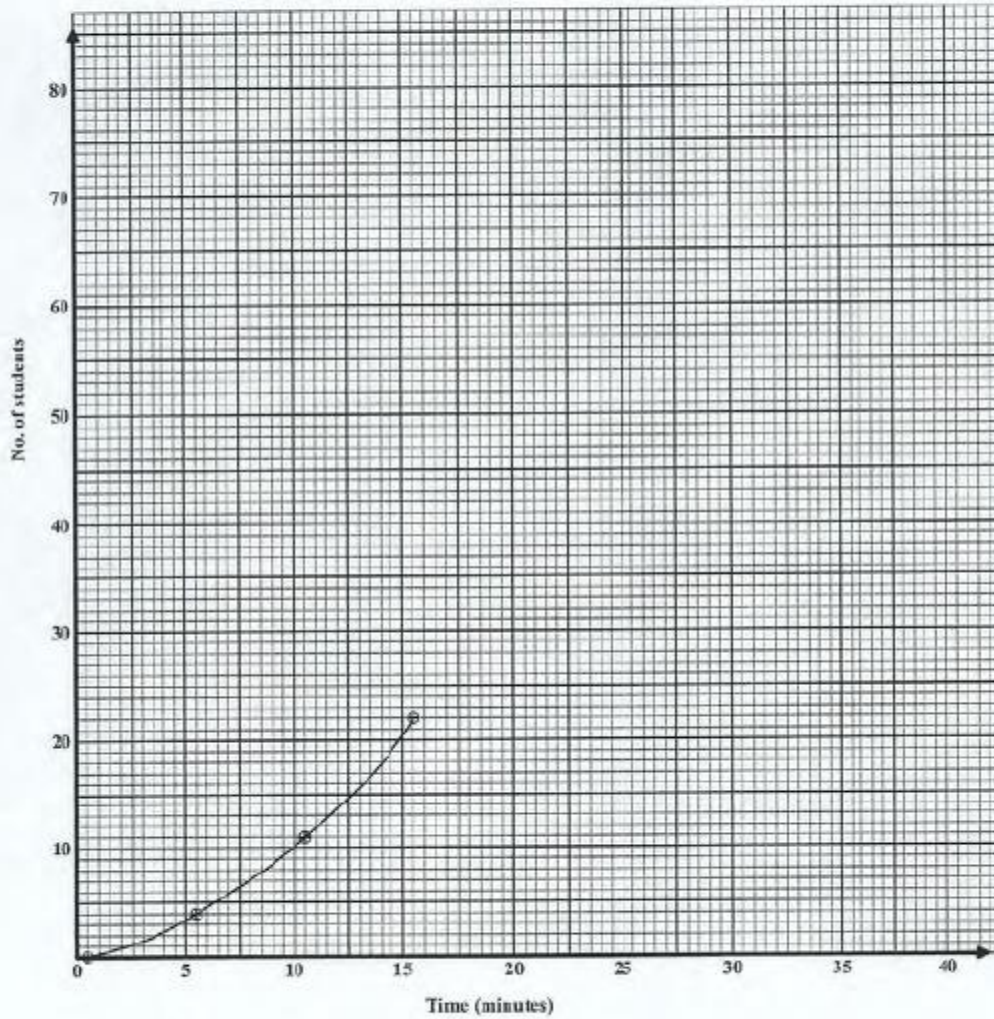

ATTACH THIS ANSWER SHEET TO YOUR ANSWER BOOKLET

TEST CODE **01234020**

FORM TP 2009092

MAY/JUNE 2009

**CARIBBEAN EXAMINATIONS COUNCIL
SECONDARY EDUCATION CERTIFICATE
EXAMINATION
MATHEMATICS
Paper 02 – General Proficiency**

Answer Sheet for Question 8

Candidate Number

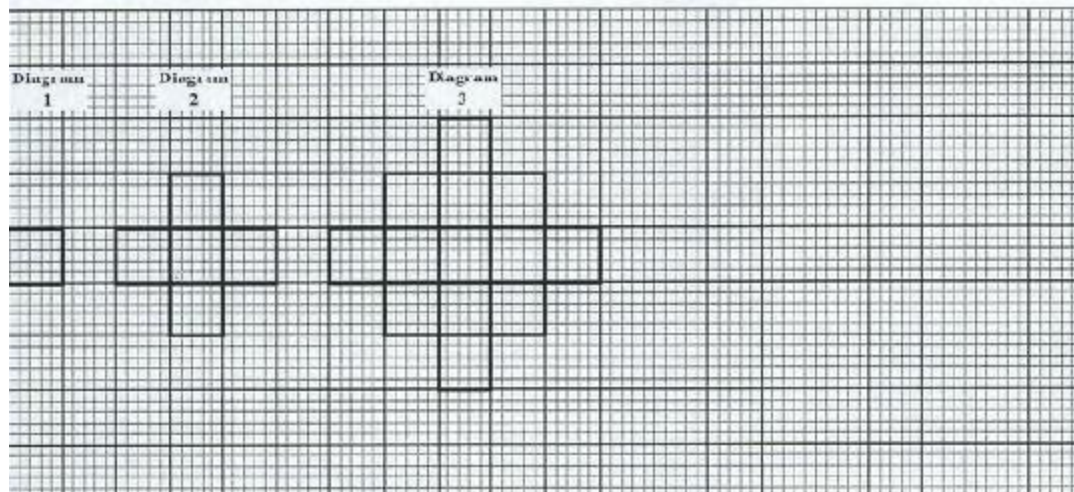

	Diagram Number	Number of Unit Squares	Pattern for Calculating Number of Unit Squares
	1	1	$1^2 + 0^2$
	2	5	$2^2 + 1^2$
	3	13	$3^2 + 2^2$
(i)	4	_____	_____ + _____
(ii)	10	_____	_____ + _____
(iii)	_____	421	_____ + _____

ATTACH THIS ANSWER SHEET TO YOUR ANSWER BOOKLET

FORM TP 2009090

TEST CODE **01134020**

MAY/JUNE 2009

**CARIBBEAN EXAMINATIONS COUNCIL
SECONDARY EDUCATION CERTIFICATE
EXAMINATION
MATHEMATICS**

Paper 02 – Basic Proficiency

2 hours 40 minutes

20 MAY 2009 (a.m.)

B

INSTRUCTIONS TO CANDIDATES

1. Answer ALL questions.
2. Write your answers in the booklet provided.
3. All working must be shown clearly.
4. A list of formulae is provided on page 2 of this booklet.

Examination Materials

Electronic calculator (non-programmable)
Geometry set
Mathematical tables
Graph paper (provided)

DO NOT TURN THIS PAGE UNTIL YOU ARE TOLD TO DO SO

Copyright © 2008 Caribbean Examinations Council®.
All rights reserved.

01134020/F 2009

LIST OF FORMULAE

Volume of a prism $V = Ah$ where A is the area of a cross-section and h is the perpendicular length.

Volume of a right pyramid $V = \frac{1}{3}Ah$ where A is the area of the base and h is the perpendicular height.

Circumference $C = 2\pi r$ where r is the radius of the circle.

Area of a circle $A = \pi r^2$ where r is the radius of the circle.

Area of trapezium $A = \frac{1}{2}(a+b)h$ where a and b are the lengths of the parallel sides and h is the perpendicular distance between the parallel sides.

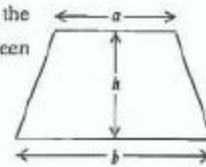
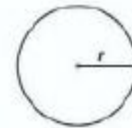

Roots of quadratic equations If $ax^2 + bx + c = 0$,
then $x = \frac{-b \pm \sqrt{b^2 - 4ac}}{2a}$

Trigonometric ratios

$$\sin \theta = \frac{\text{opposite side}}{\text{hypotenuse}}$$

$$\cos \theta = \frac{\text{adjacent side}}{\text{hypotenuse}}$$

$$\tan \theta = \frac{\text{opposite side}}{\text{adjacent side}}$$

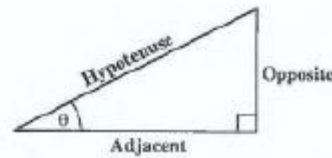

Area of triangle

Area of $\Delta = \frac{1}{2}bh$ where b is the length of the base and h is the perpendicular height

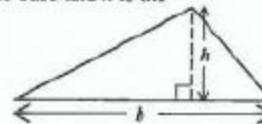

Area of sector

$$\text{Area} = \frac{\alpha}{360} \times \pi r^2$$

where α is measured in degrees.

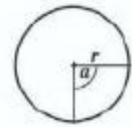

Length of Arc

$$\text{Arc length} = \frac{\alpha}{360} \times 2\pi r$$

SECTION I

All working must be clearly shown.

1. (a) Calculate the EXACT value of

$$\frac{2\frac{1}{3} - \frac{5}{6}}{2\frac{1}{4}}$$

(3 marks)

- (b) A table shows the following rate of exchange.

US \$1.00 = JM \$70.50

Convert JM \$2000 to US \$, giving your answer to two decimal places. (3 marks)

- (c) The mean (average) mass of the 11 men on the West Indies cricket team is 70 kg.

(i) Calculate the TOTAL mass, in kilograms, of the eleven-member team.

The captain of the team weighs 90 kg.

(ii) Calculate the mean (average) mass of the other 10 members of the team.

(4 marks)

Total 10 marks

2. (a) Simplify

$$\frac{8x^5 \times 3x^2}{12x^4}$$

(3 marks)

- (b) If
- $m = 3$
- and
- $n = -4$
- , calculate the value of
- $mn + n^2$
- .

(3 marks)

- (c) Solve the equation

$$\frac{2}{3}x - 1 = \frac{1}{2}x$$

(4 marks)

Total 10 marks

GO ON TO THE NEXT PAGE

3. (a) A company buys calculators for \$70.00 each and sells them for \$110.00 each.
- (i) Calculate the profit made by selling one calculator. (1 mark)
- (ii) Express your answer in (i) above as a percentage of the cost price. (2 marks)
- (iii) The company offers 18% discount on the calculators to students, as shown in the advertisement below.

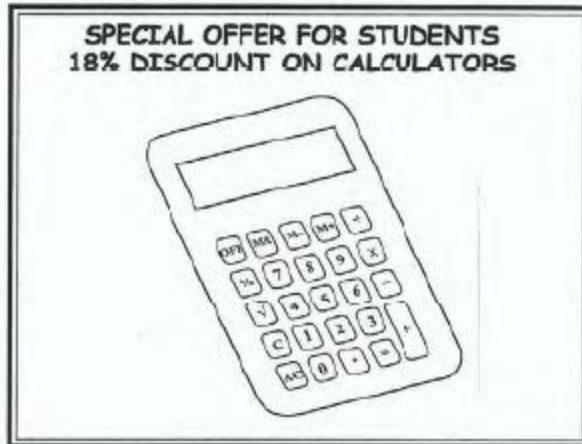

A student bought ONE calculator.

Calculate

- a) the discount on the purchase
- b) the price paid for the calculator. (4 marks)
- (b) A customer can buy a stove on hire purchase by making a down payment of \$500.00 and repaying the balance in 24 equal monthly instalments.

If the TOTAL cost of the stove on hire purchase is \$4 064.00, calculate the amount of EACH monthly instalment. (3 marks)

Total 10 marks

GO ON TO THE NEXT PAGE

4. (a) Solve for x and y :
- $$\begin{aligned} 3x - y &= 5 \\ 2x + 5y &= 9 \end{aligned} \quad (5 \text{ marks})$$
- (b) Amber was paid $\$x$ for a baby-sitting job. Pearl was paid $\$24.00$ MORE than Amber.
- (i) Write an expression in x to represent the amount of money paid to Pearl. (1 mark)
- (ii) The TOTAL amount of money paid to Amber and Pearl was $\$84.00$.
- a) Write an equation in x to represent this information.
- b) Determine the value of x . (4 marks)

Total 10 marks

5. (a) Kurt invested $\$5000$ in a Savings Account at a Credit Union at 8% simple interest per annum.
- Calculate
- (i) the interest earned at the end of 18 months (2 marks)
- (ii) the amount of time that is required to earn $\$2000$ in interest. (2 marks)
- (b) The table below shows Mr. John's electricity bill for the month of May.

Calculate the missing values at (i), (ii), (iii), (iv), (v) and (vi).

Previous Reading (i) _____ kWh	Present Reading 6129 kWh	kWh Used 216
Fixed Charge		$\$25.00$
Energy Charge	$\$1.05$ per kWh	(ii) _____
Fuel Charge	$\$0.55$ per kWh	(iii) _____
Total Charge		(iv) _____
5% Discount for Early Payment		(v) _____
Net Amount Due		(vi) _____

(6 marks)

Total 10 marks

GO ON TO THE NEXT PAGE

6. The diagram below, **not drawn to scale**, shows a quadrilateral $KLMN$.

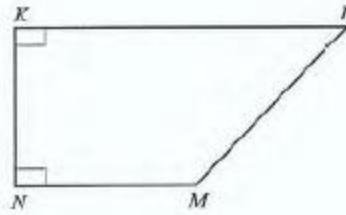

- (a) Using a **pencil, a ruler and a protractor** only, draw accurately the quadrilateral $KLMN$ such that:

$$KN = MN = 6 \text{ cm}$$

$$\angle KNM = \angle NKL = 90^\circ$$

$$KL = 10 \text{ cm}$$

(5 marks)

- (b) Measure and state

(i) the length of LM

(ii) the size of angle NML .

(2 marks)

- (c) State ONE reason why KL is parallel to NM .

(2 marks)

- (d) What type of quadrilateral is $KLMN$?

(1 mark)

Total 10 marks

7. The diagram below, **not drawn to scale**, shows a field, $ABCO$, whose boundaries are an arc ABC and two radii OA and OC of a circle.

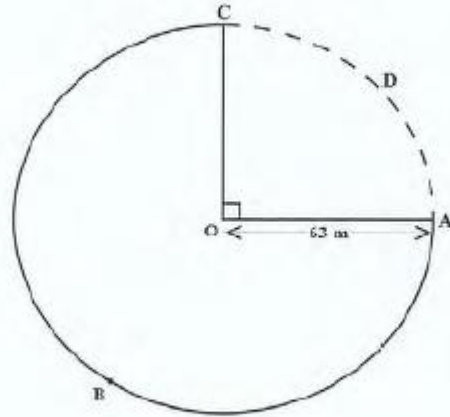

Use $\pi = \frac{22}{7}$

- (a) Calculate
- the circumference of the complete circle $ABCD$ (2 marks)
 - the length of the minor arc ADC (2 marks)
 - the perimeter of the closed field $ABCO$. (3 marks)

An athlete takes 1 minute and 30 seconds to run around the entire closed field, $ABCO$.

- (b) Calculate the speed of the athlete in ms^{-1} . (3 marks)

Total 10 marks

8. An answer sheet is provided for this question.

The graph below shows rectangle $ABCD$ and its image $A'B'C'D'$.

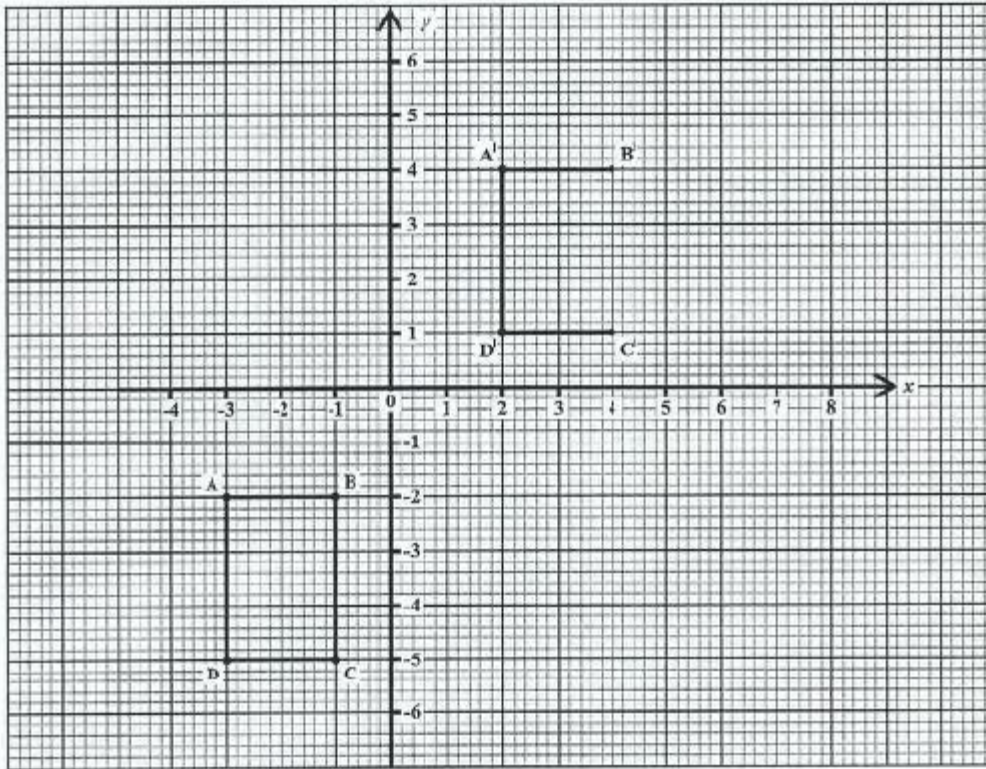

- (a) Write down the coordinates of A and A' . (2 marks)
- (b) Describe FULLY the transformation which maps $ABCD$ onto $A'B'C'D'$. (3 marks)
- (c) **On the answer sheet provided**, draw and label $A''B''C''D''$, the image of $A'B'C'D'$ after a reflection in the line $x = 5$. (5 marks)

Total 10 marks

GO ON TO THE NEXT PAGE

9. (a) The diagram below shows the graph of the function $y = 2^x$.

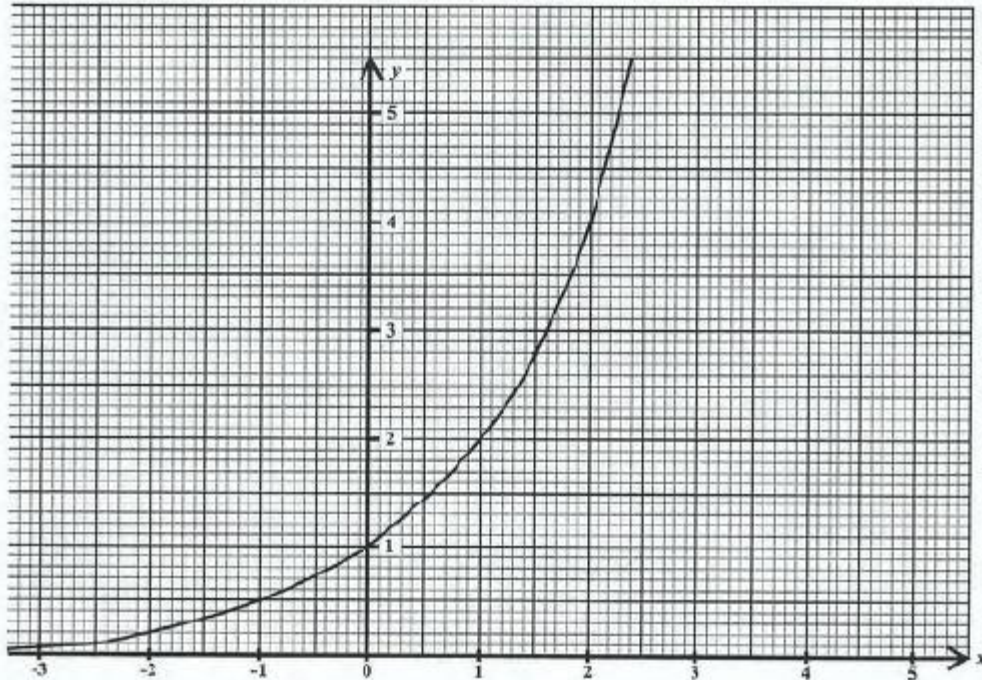

Using the graph, state the value of

- (i) y when $x = -1$
 - (ii) x when $y = 5$. (2 marks)
- (b) A straight line passes through the points $A (0, 3)$ and $B (-2, 5)$.

Determine

- (i) the gradient of the line segment AB (2 marks)
- (ii) the equation of the line segment AB (2 marks)
- (iii) the coordinates of the point where AB cuts the x axis (2 marks)
- (iv) the equation of the line which is perpendicular to AB , and passes through the origin. (2 marks)

Total 10 marks

GO ON TO THE NEXT PAGE

10. The histogram below shows the ages of the students in a Computer Club.

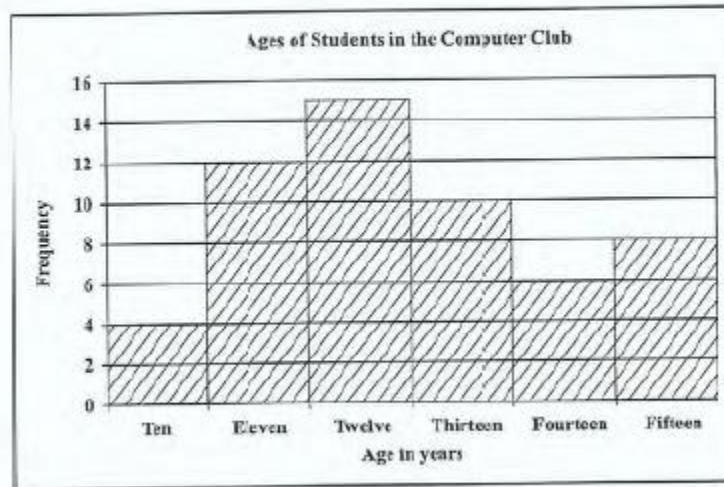

- (a) Copy and complete the frequency table below to represent the data shown in the histogram.

Age (years)	10	11	12	13	14	15
Frequency		12		10	6	8

(2 marks)

- (b) How many students are members of the Computer Club? (2 marks)
- (c) Calculate the mean age of the students in the Computer Club. (3 marks)

Javed is a member of the Computer Club. There are 14 students in the club who are older than he is.

- (d) How old is Javed? (1 mark)
- (e) Calculate the probability that a student chosen at random is twelve years old or younger. (2 marks)

Total 10 marks

END OF TEST

TEST CODE **01134020**

FORM TP 2009090

MAY/JUNE 2009

CARIBBEAN EXAMINATIONS COUNCIL

SECONDARY EDUCATION CERTIFICATE

EXAMINATION

MATHEMATICS

Paper 02 – Basic Proficiency

Answer Sheet for Question 8

Candidate Number

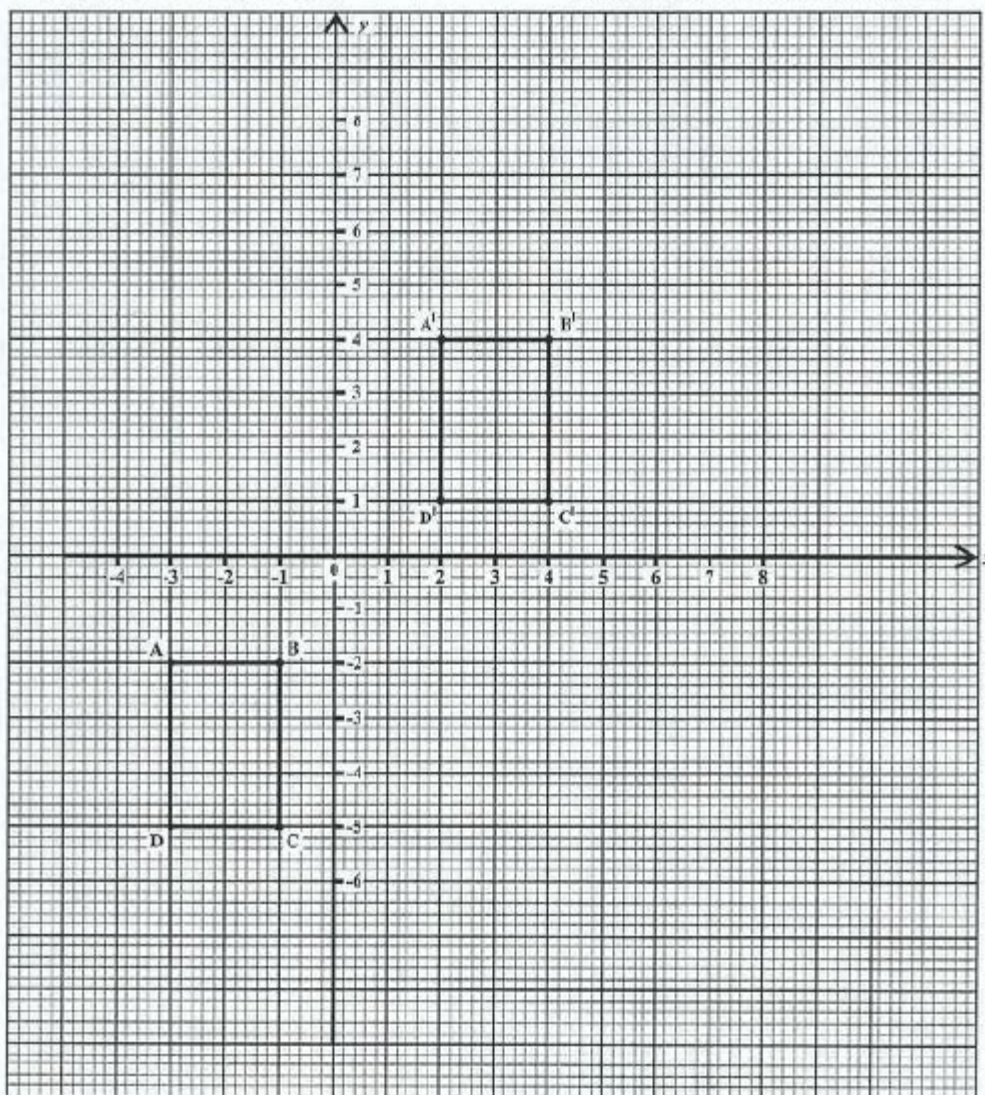

ATTACH THIS ANSWER SHEET TO YOUR ANSWER BOOKLET

01134020/F 2009

FORM TP 2010015



TEST CODE 01234020

JANUARY 2010

CARIBBEAN EXAMINATIONS COUNCIL
SECONDARY EDUCATION CERTIFICATE
EXAMINATION
MATHEMATICS

Paper 02 – General Proficiency

2 hours 40 minutes

05 JANUARY 2010 (a.m.)

INSTRUCTIONS TO CANDIDATES

1. Answer ALL questions in Section I, and ANY TWO in Section II.
2. Write your answers in the booklet provided.
3. All working must be clearly shown.
4. A list of formulae is provided on page 2 of this booklet.

Examination Materials

Electronic calculator (non-programmable)

Geometry set

Mathematical tables (provided)

Graph paper (provided)

DO NOT TURN THIS PAGE UNTIL YOU ARE TOLD TO DO SO.

Copyright © 2009 Caribbean Examinations Council®.
All rights reserved.

01234020/JANUARY/F 2010

LIST OF FORMULAE

Volume of a prism $V = Ah$ where A is the area of a cross-section and h is the perpendicular length.

Volume of cylinder $V = \pi r^2 h$ where r is the radius of the base and h is the perpendicular height.

Volume of a right pyramid $V = \frac{1}{3}Ah$ where A is the area of the base and h is the perpendicular height.

Circumference $C = 2\pi r$ where r is the radius of the circle.

Area of a circle $A = \pi r^2$ where r is the radius of the circle.

Area of trapezium $A = \frac{1}{2}(a + b)h$ where a and b are the lengths of the parallel sides and h is the perpendicular distance between the parallel sides.

Roots of quadratic equations If $ax^2 + bx + c = 0$,
then $x = \frac{-b \pm \sqrt{b^2 - 4ac}}{2a}$

Trigonometric ratios $\sin \theta = \frac{\text{opposite side}}{\text{hypotenuse}}$

$\cos \theta = \frac{\text{adjacent side}}{\text{hypotenuse}}$

$\tan \theta = \frac{\text{opposite side}}{\text{adjacent side}}$

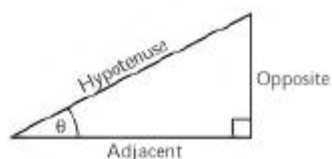

Area of triangle Area of $\Delta = \frac{1}{2}bh$ where b is the length of the base and h is the perpendicular height

Area of $\Delta ABC = \frac{1}{2}ab \sin C$

Area of $\Delta ABC = \sqrt{s(s-a)(s-b)(s-c)}$

where $s = \frac{a+b+c}{2}$

Sine rule $\frac{a}{\sin A} = \frac{b}{\sin B} = \frac{c}{\sin C}$

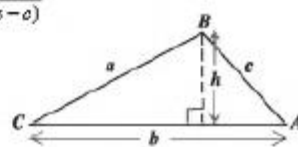

Cosine rule $a^2 = b^2 + c^2 - 2bc \cos A$

GO ON TO THE NEXT PAGE

SECTION I

Answer ALL the questions in this section.

All working must be clearly shown.

1. (a) Using a calculator, or otherwise, calculate the exact value of

$$\frac{2.76}{0.8} + 8.7^2 \quad (3 \text{ marks})$$

- (b) In a certain company, a salesman is paid a fixed salary of \$3 140 per month plus an annual commission of 2% on the TOTAL value of cars sold for the year. If the salesman sold cars valued at \$720 000 in 2009, calculate

- (i) his fixed salary for the year (1 mark)
 (ii) the amount he received in commission for the year (1 mark)
 (iii) his TOTAL income for the year. (1 mark)

- (c) The ingredients for making pancakes are shown in the diagram below.

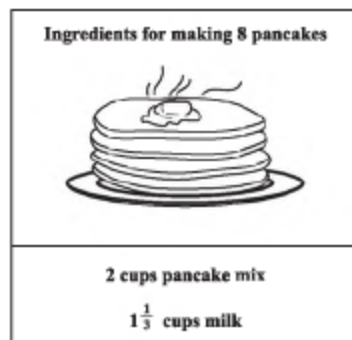

- (i) Ryan wishes to make 12 pancakes using the instructions given above. Calculate the number of cups of pancake mix he must use. (2 marks)
 (ii) Neisha used 5 cups of milk to make pancakes using the same instructions. How many pancakes did she make? (3 marks)

Total 11 marks

GO ON TO THE NEXT PAGE

2. (a) Given that $a = 6$, $b = -4$ and $c = 8$, calculate the value of

$$\frac{a^2 + b}{c - b} \quad (3 \text{ marks})$$

- (b) Simplify the expression:

(i) $3(x - y) + 4(x + 2y)$ (2 marks)

(ii) $\frac{4x^2 \times 3x^4}{6x^3}$ (3 marks)

- (c) (i) Solve the inequality

$$x - 3 < 3x - 7 \quad (3 \text{ marks})$$

- (ii) If x is an integer, determine the SMALLEST value of x that satisfies the inequality in (c) (i) above. (1 mark)

Total 12 marks

3. (a) T and E are subsets of a universal set, U , such that:

$$U = \{ 1, 2, 3, 4, 5, 6, 7, 8, 9, 10, 11, 12 \}$$

$$T = \{ \text{multiples of } 3 \}$$

$$E = \{ \text{even numbers} \}$$

- (i) Draw a Venn diagram to represent this information. (4 marks)

- (ii) List the members of the set

a) $T \cap E$ (1 mark)

b) $(T \cup E)'$ (1 mark)

GO ON TO THE NEXT PAGE

(b) Using a pencil, a ruler, and a pair of compasses only:

(i) Construct, accurately, the triangle ABC shown below, where,

$$\begin{aligned} AC &= 6 \text{ cm} \\ \angle ACB &= 60^\circ \\ \angle CAB &= 60^\circ \end{aligned}$$

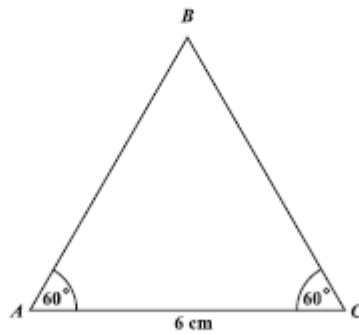

(3 marks)

(ii) Complete the diagram to show the kite, $ABCD$, in which $AD = 5$ cm.

(2 marks)

(iii) Measure and state the size of $\angle DAC$.

(1 mark)

Total 12 marks

4. (a) The diagram below, not drawn to scale, shows a triangle LMN with $LN = 12$ cm, $NM = x$ cm and $\angle NLM = \theta^\circ$. The point K on LM is such that NK is perpendicular to LM , $NK = 6$ cm, and $KM = 8$ cm.

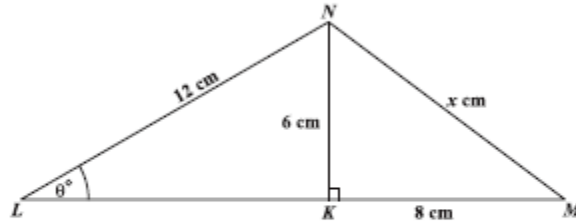

Calculate the value of

- (i) x (2 marks)
- (ii) θ . (3 marks)
- (b) The diagram below shows a map of a playing field drawn on a grid of 1 cm squares. The scale of the map is 1 : 1 250.

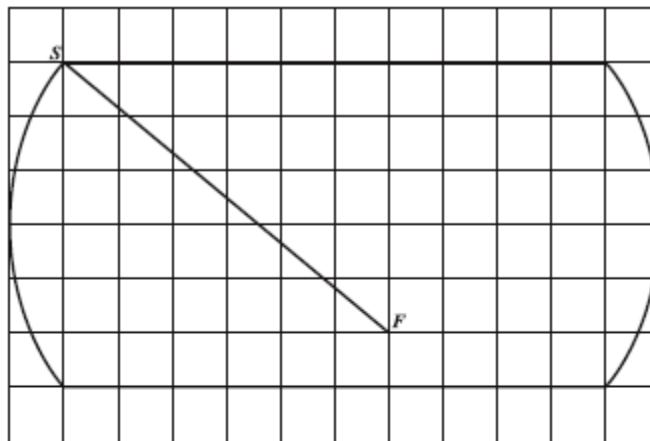

- (i) Measure and state, in centimetres, the distance from S to F on the map. (1 mark)
- (ii) Calculate the distance, in metres, from S to F on the ACTUAL playing field. (2 marks)

- (iii) Daniel ran the distance from S to F in 9.72 seconds. Calculate his average speed in
- a) m/s
- b) km/h

giving your answer correct to 3 significant figures. (3 marks)

Total 11 marks

5. (a) A straight line passes through the point $T(4,1)$ and has a gradient of $\frac{3}{5}$. Determine the equation of this line. (3 marks)
- (b) (i) Using a scale of 1 cm to represent 1 unit on both axes, draw the triangle ABC with vertices $A(2,3)$, $B(5,3)$ and $C(3,6)$. (3 marks)
- (ii) On the same axes used in (b) (i), draw and label the line $y = 2$. (1 mark)
- (iii) Draw the image of triangle ABC under a reflection in the line $y = 2$. Label the image $A'B'C'$. (2 marks)
- (iv) Draw a new triangle $A''B''C''$ with vertices $A''(-7,4)$, $B''(-4,4)$ and $C''(-6,7)$. (1 mark)
- (v) Name and describe the single transformation that maps triangle ABC onto triangle $A''B''C''$. (2 marks)

Total 12 marks

GO ON TO THE NEXT PAGE

6. A class of 26 students each recorded the distance travelled to school. The distance, to the nearest km, is recorded below:

21 11 3 22 6 32 22 18 28
 26 16 17 34 12 25 8 19 14
 39 17 22 24 30 18 13 23

- (a) Copy and complete the frequency table to represent this data.

Distance in kilometres	Frequency
1 - 5	1
6 - 10	2
11 - 15	4
16 - 20	6
21 - 25	
26 - 30	
31 - 35	
36 - 40	

(2 marks)

- (b) Using a scale of 2 cm to represent 5 km on the horizontal axis and a scale of 1 cm to represent 1 student on the vertical axis, draw a histogram to represent the data.
(5 marks)
- (c) Calculate the probability that a student chosen at random from this class recorded the distance travelled to school as 26 km or more.
(2 marks)
- (d) The P.T.A. plans to set up a transportation service for the school. Which average, mean, mode or median, is MOST appropriate for estimating the cost of the service? Give a reason for your answer.
(2 marks)

Total 11 marks

GO ON TO THE NEXT PAGE

7. The graph shown below represents a function of the form: $f(x) = ax^2 + bx + c$.

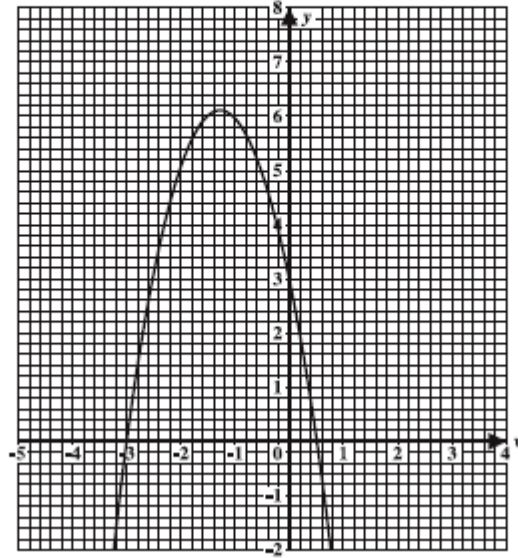

Using the graph above, determine

- (i) the value of $f(x)$ when $x = 0$ (1 mark)
- (ii) the values of x when $f(x) = 0$ (2 marks)
- (iii) the coordinates of the maximum point (2 marks)
- (iv) the equation of the axis of symmetry (2 marks)
- (v) the values of x when $f(x) = 5$ (2 marks)
- (vi) the interval within which x lies when $f(x) > 5$. Write your answer in the form $a < x < b$. (2 marks)

Total 11 marks

8. Bianca makes hexagons using sticks of equal length. She then creates patterns by joining the hexagons together. Patterns 1, 2 and 3 are shown below:

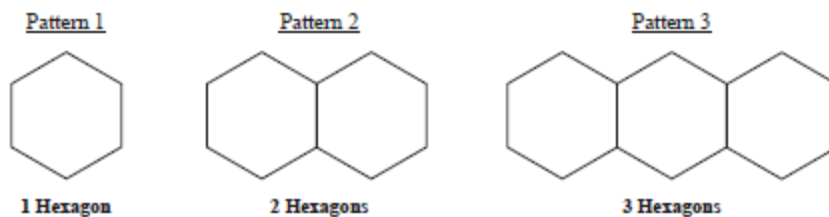

The table below shows the number of hexagons in EACH pattern created and the number of sticks used to make EACH pattern.

Number of hexagons in the pattern	1	2	3	4	5	20	n
Number of sticks used for the pattern	6	11	16	x	y	z	S

- (a) Determine the values of
- (i) x (2 marks)
 - (ii) y (2 marks)
 - (iii) z . (2 marks)
- (b) Write down an expression for S in terms of n , where S represents the number of sticks used to make a pattern of n hexagons. (2 marks)
- (c) Bianca used a total of 76 sticks to make a pattern of h hexagons. Determine the value of h . (2 marks)

Total 10 marks

GO ON TO THE NEXT PAGE

SECTION II

Answer TWO questions in this section.

RELATIONS, FUNCTIONS AND GRAPHS

9. (a) The relationship between kinetic energy, E , mass, m , and velocity, v , for a moving particle is

$$E = \frac{1}{2}mv^2.$$

- (i) Express v in terms of E and m . (3 marks)
- (ii) Determine the value of v when $E = 45$ and $m = 13$. (2 marks)
- (b) Given $g(x) = 3x^2 - 8x + 2$,
- (i) write $g(x)$ in the form $a(x + b)^2 + c$, where a , b and $c \in \mathbb{R}$ (3 marks)
- (ii) solve the equation $g(x) = 0$, writing your answer(s) correct to 2 decimal places. (4 marks)
- (iii) A sketch of the graph of $g(x)$ is shown below.

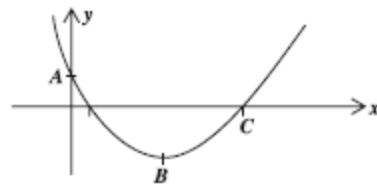

Copy the sketch and state

- a) the y -coordinate of A
- b) the x -coordinate of C
- c) the x and y -coordinates of B . (3 marks)

Total 15 marks

GO ON TO THE NEXT PAGE

10. (a) The manager of a pizza shop wishes to make x small pizzas and y large pizzas. His oven holds no more than 20 pizzas.
- (i) Write an inequality to represent the given condition. (2 marks)
- The ingredients for each small pizza cost \$15 and for each large pizza \$30. The manager plans to spend no more than \$450 on ingredients.
- (ii) Write an inequality to represent this condition. (2 marks)
- (b) (i) Using a scale of 2 cm on the x -axis to represent 5 small pizzas and 2 cm on the y -axis to represent 5 large pizzas, draw the graphs of the lines associated with the inequalities at (a) (i) and (a) (ii) above. (4 marks)
- (ii) Shade the region which is defined by ALL of the following combined:
- the inequalities written at (a) (i) and (a) (ii)
 - the inequalities $x \geq 0$ and $y \geq 0$ (1 mark)
- (iii) Using your graph, state the coordinates of the vertices of the shaded region. (2 marks)
- (c) The pizza shop makes a profit of \$8 on the sale of EACH small pizza and \$20 on the sale of EACH large pizza. All the pizzas that were made were sold.
- (i) Write an expression in x and y for the TOTAL profit made on the sale of the pizzas. (1 mark)
- (ii) Use the coordinates of the vertices given at (b) (iii) to determine the MAXIMUM profit. (3 marks)

Total 15 marks

GEOMETRY AND TRIGONOMETRY

11. (a) The diagram below, not drawn to scale, shows three stations P , Q and R , such that the bearing of Q from R is 116° and the bearing of P from R is 242° . The vertical line at R shows the North direction.

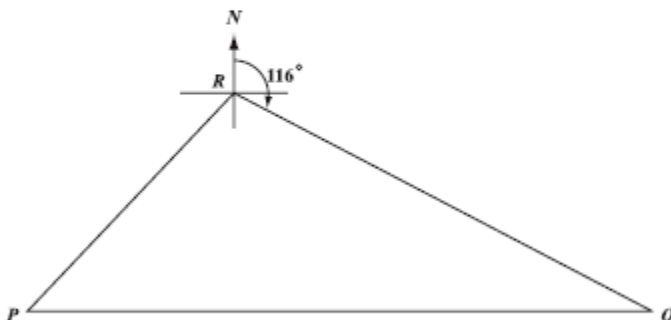

- (i) Show that angle $PRQ = 126^\circ$. (2 marks)
- (ii) Given that $PR = 38$ metres and $QR = 102$ metres, calculate the distance PQ , giving your answer to the nearest metre. (3 marks)
- (b) K , L and M are points along a straight line on a horizontal plane, as shown below.



A vertical pole, SK , is positioned such that the angles of elevation of the top of the pole S from L and M are 21° and 14° respectively.

The height of the pole, SK , is 10 metres.

- (i) Copy and complete the diagram to show the pole SK and the angles of elevation of S from L and M . (4 marks)
- (ii) Calculate, correct to ONE decimal place,
- a) the length of KL
- b) the length of LM . (6 marks)

Total 15 marks

12. (a) The diagram below, not drawn to scale, shows two circles. C is the centre of the smaller circle, GH is a common chord and DEF is a triangle.

Angle $GCH = 88^\circ$ and angle $GHE = 126^\circ$.

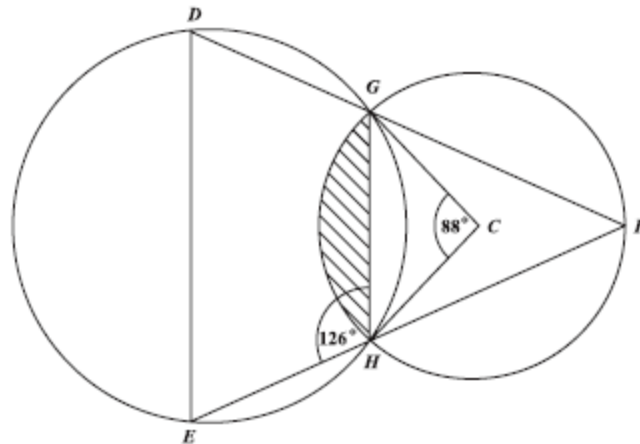

Calculate, giving reasons for your answer, the measure of angle

- (i) GFH (2 marks)
 (ii) GDE (3 marks)
 (iii) DEF . (2 marks)
- (b) Use $\pi = 3.14$ in this part of the question.

Given that $GC = 4$ cm, calculate the area of

- (i) triangle GCH (3 marks)
 (ii) the minor sector bounded by arc GH and radii GC and HC (3 marks)
 (iii) the shaded segment. (2 marks)

Total 15 marks

VECTORS AND MATRICES

13. (a) The figure below, not drawn to scale, shows the points $O(0,0)$, $A(5,0)$ and $B(-1,4)$ which are the vertices of a triangle OAB .

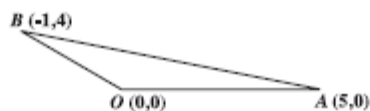

- (i) Express in the form $\begin{pmatrix} a \\ b \end{pmatrix}$ the vectors
- \vec{OB}
 - $\vec{OA} + \vec{OB}$ (3 marks)
- (ii) If $M(x,y)$ is the midpoint of AB , determine the values of x and y . (2 marks)
- (b) In the figure below, not drawn to scale, OE , EF and MF are straight lines. The point H is such that $EF = 3EH$. The point G is such that $MF = 5MG$. M is the midpoint of OE .

The vector $\vec{OM} = v$ and $\vec{EH} = u$.

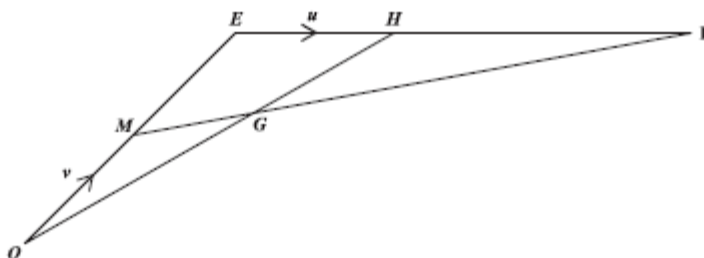

- (i) Write in terms of u and/or v , an expression for:
- \vec{HF} (1 mark)
 - \vec{MF} (2 marks)
 - \vec{OH} (2 marks)
- (ii) Show that $\vec{OG} = \frac{3}{5} (2v + u)$ (2 marks)
- (iii) Hence, prove that O , G and H lie on a straight line. (3 marks)

Total 15 marks
GO ON TO THE NEXT PAGE

14. (a) L and N are two matrices where

$$L = \begin{bmatrix} 3 & 2 \\ 1 & 4 \end{bmatrix} \quad \text{and} \quad N = \begin{bmatrix} -1 & 3 \\ 0 & 2 \end{bmatrix}.$$

Evaluate $L - N^2$. (3 marks)

- (b) The matrix, M , is given as $M = \begin{bmatrix} x & 12 \\ 3 & x \end{bmatrix}$. Calculate the values of x for which M is singular. (2 marks)

- (c) A geometric transformation, R , maps the point $(2,1)$ onto $(-1,2)$.

Given that $R = \begin{bmatrix} 0 & p \\ q & 0 \end{bmatrix}$, calculate the values of p and q . (3 marks)

- (d) A translation, $T = \begin{bmatrix} r \\ s \end{bmatrix}$ maps the point $(5,3)$ onto $(1,1)$. Determine the values of r and s . (3 marks)

- (e) Determine the coordinates of the image of $(8,5)$ under the combined transformation, R followed by T . (4 marks)

Total 15 marks

END OF TEST

FORM TP 2010087



TEST CODE **01234020**

MAY/JUNE 2010

CARIBBEAN EXAMINATIONS COUNCIL
SECONDARY EDUCATION CERTIFICATE
EXAMINATION
MATHEMATICS

Paper 02 – General Proficiency

2 hours 40 minutes

19 MAY 2010 (a.m.)

INSTRUCTIONS TO CANDIDATES

1. This paper consists of **TWO** sections.
2. There are **EIGHT** questions in Section I and **THREE** questions in Section II.
3. Answer **ALL** questions in Section I, and any **TWO** questions from Section II.
4. Write your answers in the booklet provided.
5. All working must be clearly shown.
6. A list of formulae is provided on page 2 of this booklet.

Required Examination Materials

Electronic calculator
Geometry set
Graph paper (provided)

DO NOT TURN THIS PAGE UNTIL YOU ARE TOLD TO DO SO.

Copyright © 2008 Caribbean Examinations Council®.
All rights reserved.

01234020/F 2010

LIST OF FORMULAE

Volume of a prism	$V = Ah$ where A is the area of a cross-section and h is the perpendicular length.
Volume of cylinder	$V = \pi r^2 h$ where r is the radius of the base and h is the perpendicular height.
Volume of a right pyramid	$V = \frac{1}{3} Ah$ where A is the area of the base and h is the perpendicular height.
Circumference	$C = 2\pi r$ where r is the radius of the circle.
Area of a circle	$A = \pi r^2$ where r is the radius of the circle.
Area of trapezium	$A = \frac{1}{2} (a + b) h$ where a and b are the lengths of the parallel sides and h is the perpendicular distance between the parallel sides.

Roots of quadratic equations If $ax^2 + bx + c = 0$,
then $x = \frac{-b \pm \sqrt{b^2 - 4ac}}{2a}$

Trigonometric ratios

$$\sin \theta = \frac{\text{opposite side}}{\text{hypotenuse}}$$

$$\cos \theta = \frac{\text{adjacent side}}{\text{hypotenuse}}$$

$$\tan \theta = \frac{\text{opposite side}}{\text{adjacent side}}$$



Area of triangle Area of $\Delta = \frac{1}{2} bh$ where b is the length of the base and h is the perpendicular height

$$\text{Area of } \Delta ABC = \frac{1}{2} ab \sin C$$

$$\text{Area of } \Delta ABC = \sqrt{s(s-a)(s-b)(s-c)}$$

$$\text{where } s = \frac{a+b+c}{2}$$

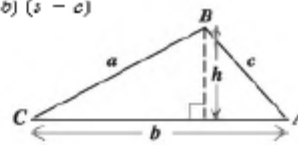
Sine rule $\frac{a}{\sin A} = \frac{b}{\sin B} = \frac{c}{\sin C}$



Cosine rule $a^2 = b^2 + c^2 - 2bc \cos A$

GO ON TO THE NEXT PAGE

SECTION I

Answer ALL the questions in this section.

All working must be clearly shown.

1. (a) Determine the EXACT value of:

$$(i) \frac{1\frac{1}{2} - \frac{2}{5}}{4\frac{2}{3} \times \frac{3}{4}} \quad (3 \text{ marks})$$

$$(ii) 2.5^2 - \frac{2.89}{17}$$

giving your answer correct to 2 significant figures (3 marks)

- (b) Mrs. Jack bought 150 T-shirts for \$1 920 from a factory.

- (i) Calculate the cost of ONE T-shirt. (1 mark)



The T-shirts are sold at \$19.99 each.

Calculate

- (ii) the amount of money Mrs. Jack received after selling ALL of the T-shirts (1 mark)
- (iii) the TOTAL profit made (1 mark)
- (iv) the profit made as a percentage of the cost price, giving your answer correct to the nearest whole number. (2 marks)

Total 11 marks

GO ON TO THE NEXT PAGE

2. (a) Given that $a = -1$, $b = 2$ and $c = -3$, find the value of:
- (i) $a + b + c$ (1 mark)
- (ii) $b^2 - c^2$ (1 mark)
- (b) Write the following phrases as algebraic expressions:
- (i) seven times the sum of x and y (1 mark)
- (ii) the product of TWO consecutive numbers when the smaller number is y (1 mark)
- (c) Solve the pair of simultaneous equations:
- $$\begin{aligned} 2x + y &= 7 \\ x - 2y &= 1 \end{aligned}$$
- (3 marks)
- (d) Factorise completely:
- (i) $4y^2 - z^2$ (1 mark)
- (ii) $2ax - 2ay - bx + by$ (2 marks)
- (iii) $3x^2 + 10x - 8$ (2 marks)
- Total 12 marks

3. (a) A survey was conducted among 40 tourists. The results were:
- 28 visited Antigua (A)
- 30 visited Barbados (B)
- $3x$ visited both Antigua and Barbados
- x visited neither Antigua nor Barbados
- (i) Copy and complete the Venn diagram below to represent the given information above.

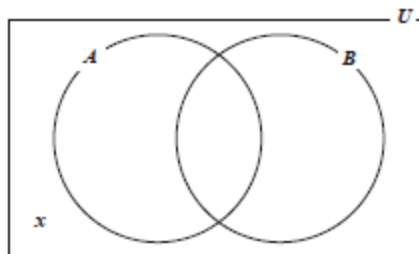

- (2 marks)
- (ii) Write an expression, in x , to represent the TOTAL number of tourists in the survey. (2 marks)
- (iii) Calculate the value of x . (2 marks)

GO ON TO THE NEXT PAGE

- (b) The diagram below, not drawn to scale, shows a wooden toy in the shape of a prism, with cross section $ABCDE$. F is the midpoint of EC , and $\angle BAE = \angle CBA = 90^\circ$.

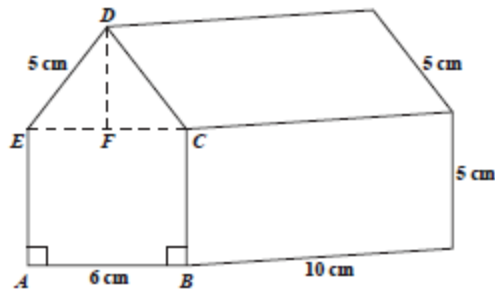

Calculate

- (i) the length of EF (1 mark)
- (ii) the length of DF (2 marks)
- (iii) the area of the face $ABCDE$. (3 marks)

Total 12 marks

4. (a) When y varies directly as the square of x , the variation equation is written $y = kx^2$, where k is a constant.
- (i) Given that $y = 50$ when $x = 10$, find the value of k . (2 marks)
 - (ii) Calculate the value of y when $x = 30$. (2 marks)
- (b) (i) Using a ruler, a pencil and a pair of compasses, construct triangle EFG with $EG = 6\text{ cm}$, $\angle FEG = 60^\circ$ and $\angle EGF = 90^\circ$. (5 marks)
- (ii) Measure and state
 - a) the length of EF
 - b) the size of $\angle EFG$. (2 marks)

Total 11 marks

GO ON TO THE NEXT PAGE

5. (a) The functions f and g are defined as $f(x) = 2x - 5$ and $g(x) = x^2 + 3$.
- (i) Calculate the value of
- a) $f(4)$ (1 mark)
- b) $gf(4)$. (2 marks)
- (ii) Find $f^{-1}(x)$. (2 marks)
- (b) The diagram below shows the graph of $y = x^2 + 2x - 3$ for the domain $-4 \leq x \leq 2$.

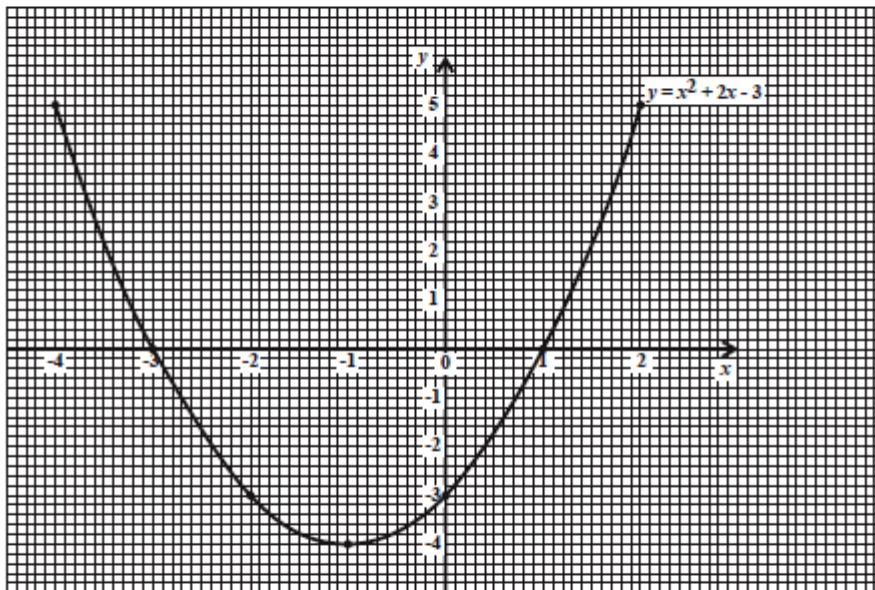

Use the graph above to determine

- (i) the scale used on the x -axis (1 mark)
- (ii) the value of y for which $x = -1.5$ (2 marks)
- (iii) the values of x for which $y = 0$ (2 marks)
- (iv) the range of values of y , giving your answer in the form $a \leq y \leq b$, where a and b are real numbers. (2 marks)

Total 12 marks

GO ON TO THE NEXT PAGE

6. An answer sheet is provided for this question.

- (a) The diagram below, not drawn to scale, shows two straight lines, PQ and RS , intersecting a pair of parallel lines, TU and VW .

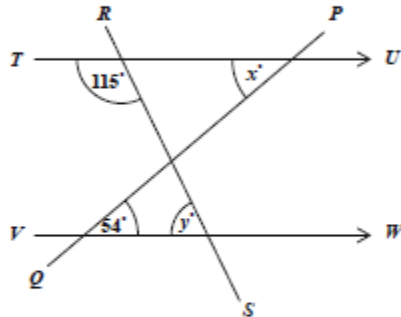

Determine, giving a reason for EACH of your answers, the value of

- (i) x (2 marks)
 (ii) y . (2 marks)
- (b) The diagram below shows triangle LMN , and its image, triangle $L'M'N'$, after undergoing a rotation.

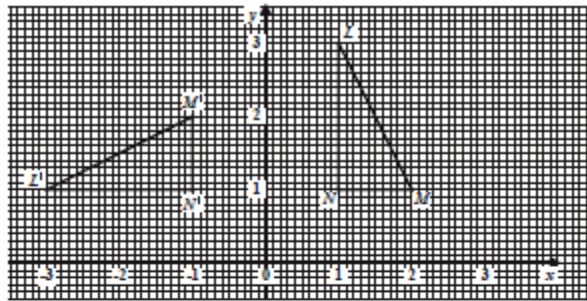

- (i) Describe the rotation FULLY by stating
 a) the centre
 b) the angle
 c) the direction. (3 marks)
- (ii) State TWO geometric relationships between triangle LMN and its image, triangle $L'M'N'$. (2 marks)
- (iii) Triangle LMN is translated by the vector $\begin{pmatrix} 1 \\ -2 \end{pmatrix}$.

Determine the coordinates of the image of the point L under this transformation. (2 marks)

Total 11 marks

GO ON TO THE NEXT PAGE

7. A class of 24 students threw the cricket ball at sports. The distance thrown by each student was measured to the nearest metre. The results are shown below.

22	50	35	52	47	30
48	34	45	23	43	40
55	29	46	56	43	59
36	63	54	32	49	60

- (a) Copy and complete the frequency table for the data shown above.

Distance (m)	Frequency
20 – 29	3
30 – 39	5
_____	_____
_____	_____
_____	_____

(3 marks)

- (b) State the lower boundary for the class interval 20 – 29. (1 mark)
- (c) Using a scale of 1 cm on the x-axis to represent 5 metres, and a scale of 1 cm on the y-axis to represent 1 student, draw a histogram to illustrate the data. (5 marks)
- (d) Determine
- the number of students who threw the ball a distance recorded as 50 metres or more (1 mark)
 - the probability that a student, chosen at random, threw the ball a distance recorded as 50 metres or more. (1 mark)

Total 11 marks

8. An answer sheet is provided for this question.

The diagram below shows the first three figures in a sequence of figures. Each figure is made up of squares of side 1 cm.

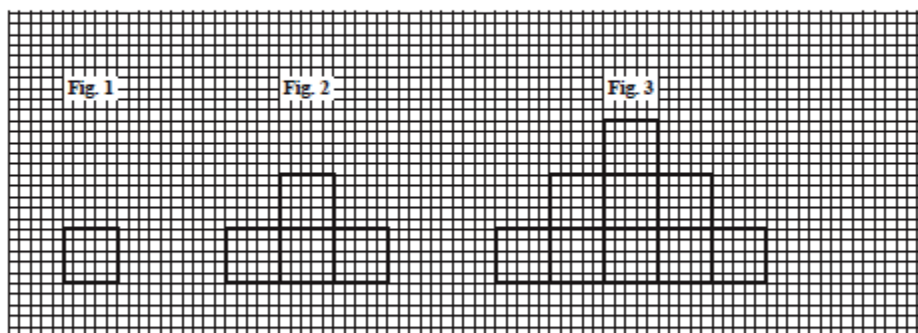

- (a) On your answer sheet, draw the FOURTH figure (Fig. 4) in the sequence. (2 marks)
- (b) Study the patterns in the table shown below, and on the answer sheet provided, complete the rows numbered (i), (ii), (iii) and (iv).

Figure	Area of Figure (cm ²)	Perimeter of Figure (cm)
1	1	$1 \times 6 - 2 = 4$
2	4	$2 \times 6 - 2 = 10$
3	9	$3 \times 6 - 2 = 16$
(i) 4	_____	_____ (2 marks)
(ii) 5	_____	_____ (2 marks)
(iii) 15	_____	_____ (2 marks)
(iv) n	_____	_____ (2 marks)

Total 10 marks

GO ON TO THE NEXT PAGE

SECTION II

Answer TWO questions in this section.

ALGEBRA AND RELATIONS, FUNCTIONS AND GRAPHS

9. (a) The diagram below shows the speed-time graph of the motion of an athlete during a race.

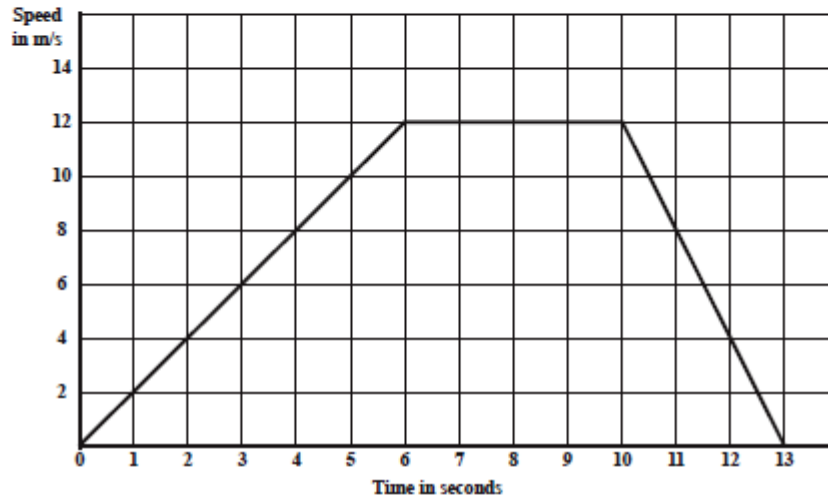

- (i) Using the graph, determine
- the MAXIMUM speed
 - the number of seconds for which the speed was constant
 - the TOTAL distance covered by the athlete during the race.
- (4 marks)
- (ii) During which time-period of the race was
- the speed of the athlete increasing
 - the speed of the athlete decreasing
 - the acceleration of the athlete zero?
- (3 marks)

- (b) A farmer supplies his neighbours with x pumpkins and y melons daily, using the following conditions:

First condition : $y \geq 3$

Second condition : $y \leq x$

Third condition : the total number of pumpkins and melons must not exceed 12.

- (i) Write an inequality to represent the THIRD condition. (1 mark)
- (ii) Using a scale of 1 cm to represent one pumpkin on the x -axis and 1 cm to represent one melon on the y -axis, draw the graphs of the THREE lines associated with the THREE inequalities. (4 marks)
- (iii) Identify, by shading, the region which satisfies the THREE inequalities. (1 mark)
- (iv) Determine, from your graph, the minimum values of x and y which satisfy the conditions. (2 marks)

Total 15 marks

MEASUREMENT, GEOMETRY AND TRIGONOMETRY

10. (a) In the diagram below, not drawn to scale, PQ is a tangent to the circle $PTSR$, so that $\angle RPQ = 46^\circ$
 $\angle RQP = 32^\circ$
 and TRQ is a straight line.

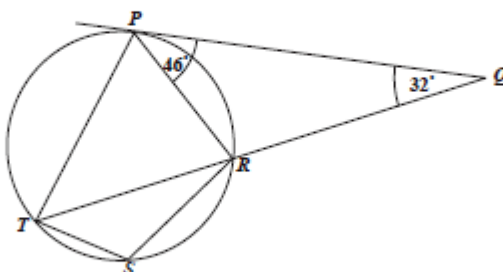

Calculate, giving a reason for EACH step of your answer,

- (i) $\angle PTR$ (2 marks)
 (ii) $\angle TPR$ (3 marks)
 (iii) $\angle TSR$. (2 marks)
- (b) The diagram below, not drawn to scale, shows a vertical flagpole, FT , with its foot, F , on the horizontal plane EFG . ET and GT are wires which support the flagpole in its position. The angle of elevation of T from G is 55° , $EF = 8$ m, $FG = 6$ m and $\angle EFG = 120^\circ$.

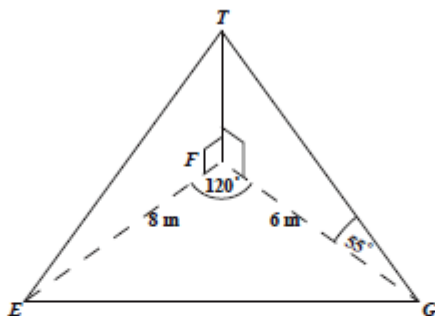

Calculate, giving your answer correct to 3 significant figures

- (i) the height, FT , of the flagpole (2 marks)
 (ii) the length of EG (3 marks)
 (iii) the angle of elevation of T from E . (3 marks)

Total 15 marks

GO ON TO THE NEXT PAGE

VECTORS AND MATRICES

11. (a) **A** and **B** are two 2×2 matrices such that

$$\mathbf{A} = \begin{pmatrix} 1 & 2 \\ 2 & 5 \end{pmatrix} \quad \text{and} \quad \mathbf{B} = \begin{pmatrix} 5 & -2 \\ -2 & 1 \end{pmatrix}.$$

- (i) Find **AB**. (2 marks)
 (ii) Determine \mathbf{B}^{-1} , the inverse of **B**. (1 mark)

- (iii) Given that

$$\begin{pmatrix} 5 & -2 \\ -2 & 1 \end{pmatrix} \begin{pmatrix} x \\ y \end{pmatrix} = \begin{pmatrix} 2 \\ 3 \end{pmatrix},$$

write $\begin{pmatrix} x \\ y \end{pmatrix}$ as the product of TWO matrices. (2 marks)

- (iv) Hence, calculate the values of x and y . (2 marks)

- (b) The diagram below, **not drawn to scale**, shows triangle JKL .

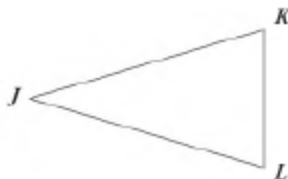

M and N are points on JK and JL respectively, such that

$$JM = \frac{1}{3} JK \quad \text{and} \quad JN = \frac{1}{3} JL.$$

- (i) Copy the diagram in your answer booklet and show the points M and N . (2 marks)

- (ii) Given that $\vec{JM} = \mathbf{u}$ and $\vec{JN} = \mathbf{v}$,
write, in terms of \mathbf{u} and \mathbf{v} , an expression for

a) \vec{JK}

b) \vec{MN}

c) \vec{KL} . (4 marks)

- (iii) Using your findings in (b) (ii), deduce TWO geometrical relationships between KL and MN . (2 marks)

Total 15 marks

END OF TEST

CARIBBEAN EXAMINATIONS COUNCIL
SECONDARY EDUCATION CERTIFICATE
EXAMINATION
MATHEMATICS

Paper 02 – General Proficiency

Answer Sheet for Question 8

Candidate Number

(a)

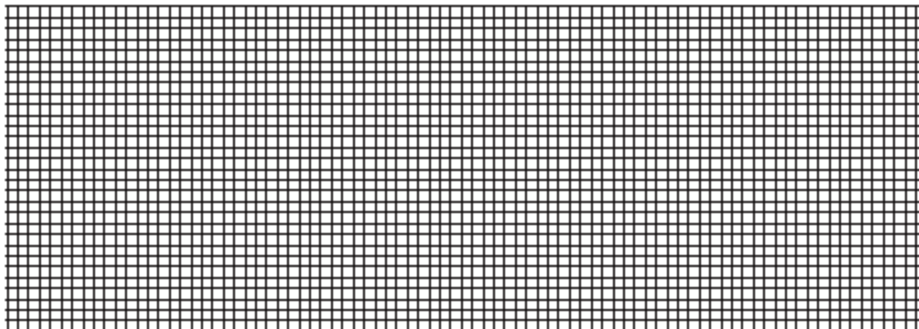

(b)

	Figure	Area of Figure (cm ²)	Perimeter of Figure (cm)
	1	1	$1 \times 6 - 2 = 4$
	2	4	$2 \times 6 - 2 = 10$
	3	9	$3 \times 6 - 2 = 16$
(i)	4	_____	_____
(ii)	5	_____	_____
(iii)	15	_____	_____
(iv)	n	_____	_____

ATTACH THIS ANSWER SHEET TO YOUR ANSWER BOOKLET

CARIBBEAN EXAMINATIONS COUNCIL
 SECONDARY EDUCATION CERTIFICATE
 EXAMINATION
 MATHEMATICS

Paper 02 – General Proficiency

Answer Sheet for Question 6

Candidate Number

(a)

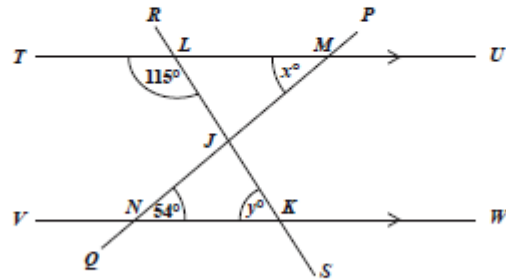

- (i) $x =$ _____
 (ii) $y =$ _____

(b)

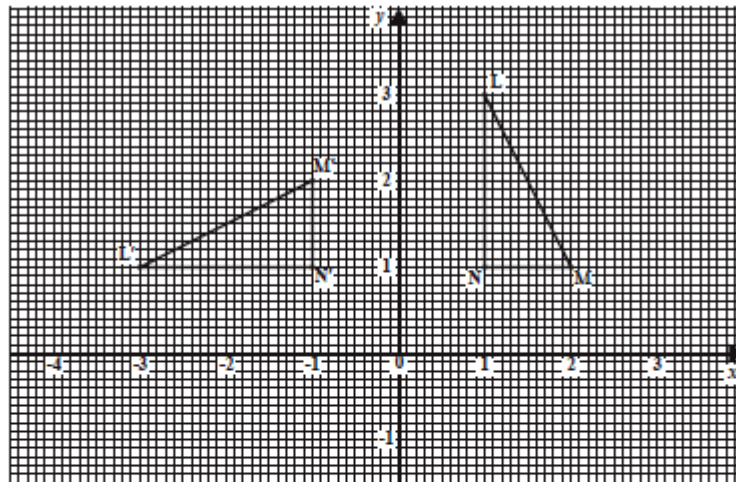

- (i) a) centre of rotation _____
 b) angle of rotation _____
 c) direction of rotation _____
- (ii) LMN and $L'M'N'$ are _____ and _____
- (iii) Image of L under the translation is (,)

ATTACH THIS ANSWER SHEET TO YOUR ANSWER BOOKLET

FORM TP 2011017



TEST CODE **01234020**

JANUARY 2011

CARIBBEAN EXAMINATIONS COUNCIL
SECONDARY EDUCATION CERTIFICATE
EXAMINATION
MATHEMATICS

Paper 02 – General Proficiency

2 hours 40 minutes

04 JANUARY 2011 (a.m.)

INSTRUCTIONS TO CANDIDATES

1. This paper consists of **TWO** sections.
2. There are **EIGHT** questions in Section I and **THREE** questions in Section II.
3. Answer **ALL** questions in Section I, and any **TWO** questions from Section II.
4. Write your answers in the booklet provided.
5. All working must be clearly shown.
6. A list of formulae is provided on page 2 of this booklet.

Required Examination Materials:

Electronic calculator
Geometry set
Graph paper (provided)

DO NOT TURN THIS PAGE UNTIL YOU ARE TOLD TO DO SO.

Copyright © 2009 Caribbean Examinations Council®.
All rights reserved.

01234020/JANUARY/F 2011

LIST OF FORMULAE

Volume of a prism	$V = Ah$ where A is the area of a cross-section and h is the perpendicular length.
Volume of cylinder	$V = \pi r^2 h$ where r is the radius of the base and h is the perpendicular height.
Volume of a right pyramid	$V = \frac{1}{3}Ah$ where A is the area of the base and h is the perpendicular height.
Circumference	$C = 2\pi r$ where r is the radius of the circle.

Arc length $S = \frac{\theta}{360} \times 2\pi r$ where θ is the angle subtended by the arc, measured in degrees.

Area of a circle $A = \pi r^2$ where r is the radius of the circle.

Area of a sector $A = \frac{\theta}{360} \times \pi r^2$ where θ is the angle of the sector, measured in degrees.

Area of trapezium $A = \frac{1}{2}(a + b)h$ where a and b are the lengths of the parallel sides and h is the perpendicular distance between the parallel sides.

Roots of quadratic equations If $ax^2 + bx + c = 0$,

$$\text{then } x = \frac{-b \pm \sqrt{b^2 - 4ac}}{2a}$$

Trigonometric ratios $\sin \theta = \frac{\text{opposite side}}{\text{hypotenuse}}$

$$\cos \theta = \frac{\text{adjacent side}}{\text{hypotenuse}}$$

$$\tan \theta = \frac{\text{opposite side}}{\text{adjacent side}}$$

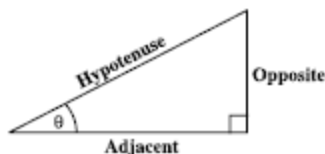

Area of triangle Area of $\Delta = \frac{1}{2}bh$ where b is the length of the base and h is the perpendicular height

$$\text{Area of } \Delta ABC = \frac{1}{2}ab \sin C$$

$$\text{Area of } \Delta ABC = \sqrt{s(s-a)(s-b)(s-c)}$$

$$\text{where } s = \frac{a+b+c}{2}$$

Sine rule $\frac{a}{\sin A} = \frac{b}{\sin B} = \frac{c}{\sin C}$

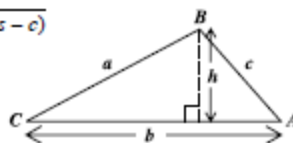

Cosine rule $a^2 = b^2 + c^2 - 2bc \cos A$

GO ON TO THE NEXT PAGE

SECTION I

Answer ALL the questions in this section.

All working must be clearly shown.

1. (a) Calculate the exact value of
- (i) $(5.8^2 + 1.02) \times 2.5$ (2 marks)
- (ii) $\frac{2\frac{4}{5}}{4\frac{2}{3}} - \frac{3}{7}$. (3 marks)
- (b) A company pays its employees a basic wage of \$9.50 per hour for a 40-hour week.
- (i) Calculate the basic weekly wage for ONE employee. (1 mark)
- Overtime is paid at a rate of time and a half.
- (ii) Calculate the overtime wage for an employee who works 6 hours overtime in a certain week. (2 marks)
- In a certain week, the company paid its 30 employees a total of \$12 084.00 in basic and overtime wages. Calculate for that week:
- (iii) The TOTAL paid in overtime wages (2 marks)
- (iv) The TOTAL number of overtime hours worked by employees (1 mark)

Total 11 marks

2. (a) Simplify
- $$\frac{2x}{5} - \frac{x}{3}$$
- expressing your answer as a single fraction. (2 marks)
- (b) Factorise completely
- $$a^2b + 2ab$$
- (1 mark)
- (c) Express p as the subject of the formula
- $$q = \frac{p^2 - r}{t}$$
- (3 marks)

GO ON TO THE NEXT PAGE

- (d) The students in a class sell donuts to raise money for their school project. The donuts are sold in small and large boxes. The number of donuts in EACH type of box is given in the table below:

Type of Box	Number of Donuts per Box
Small box	x
Large box	$2x + 3$

The students sold 8 small boxes and 5 large boxes in all.

- (i) Write an expression in terms of x to represent the TOTAL number of donuts sold. (2 marks)
- (ii) The total number of donuts sold was 195. Calculate the number of donuts in a
- small box
 - large box. (4 marks)

Total 12 marks

3. (a) Simplify the expression

$$7p^6q^3 \times 2p^2q. \quad (2 \text{ marks})$$

- (b) Fresh Farms Dairy sells milk in cartons in the shape of a cuboid with internal dimensions 6 cm by 4 cm by 10 cm.

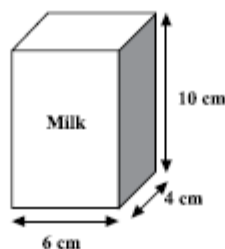

- (i) Calculate, in cm^3 , the volume of milk in EACH carton. (2 marks)
- (ii) A recipe for making ice-cream requires 3 litres of milk. How many cartons of milk should be bought to make the ice-cream? (3 marks)
- (iii) One carton of milk is poured into a cylindrical cup of internal diameter 5 cm. What is the height of milk in the cup? Give your answer to 3 significant figures. [Use $\pi = 3.14$] (4 marks)

Total 11 marks

GO ON TO THE NEXT PAGE

4. (a) The Universal set, U , is given as
 $U = \{ \text{Whole numbers from 1 to 12} \}$
 H is a subset of U , such that $H = \{ \text{Odd numbers between 4 and 12} \}$.
- (i) List the members of the set H . (1 mark)
- J is a subset of U , such that $J = \{ \text{Prime numbers} \}$.
- (ii) List the members of the set J . (1 mark)
- (iii) Draw a Venn diagram to represent the sets U, H and J , showing ALL the elements in the subsets. (3 marks)
- (b) (i) Using a pencil, ruler and a pair of compasses only, construct a triangle LMN with angle $LMN = 60^\circ$, $MN = 9$ cm and $LM = 7$ cm.
 ALL construction lines MUST be clearly shown. (4 marks)
- (ii) Measure and state the size of $\angle MNL$. (1 mark)
- (iii) On the diagram, show the point, K , such that $KLMN$ is a parallelogram. (2 marks)
- Total 12 marks

5. (a) The equation of a straight line is given by:
 $3y = 2x - 6$
- Determine
- (i) the gradient of the line (2 marks)
- (ii) the equation of the line which is perpendicular to $3y = 2x - 6$, and passes through the point $(4, 7)$. (3 marks)
- (b) The arrow diagram shown below represents the relation $f: x \rightarrow x^2 - k$, where $x \in \{3, 4, 5, 6, 7, 8, 9, 10\}$

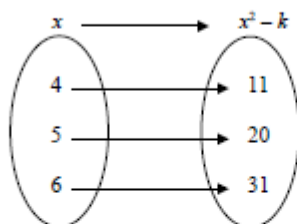

Calculate the value of

- (i) k (2 marks)
- (ii) $f(3)$ (2 marks)
- (iii) x when $f(x) = 95$. (2 marks)

Total 11 marks

GO ON TO THE NEXT PAGE

6. The line graph below shows the monthly sales, in thousands of dollars, at a school cafeteria for the period January to May 2010.

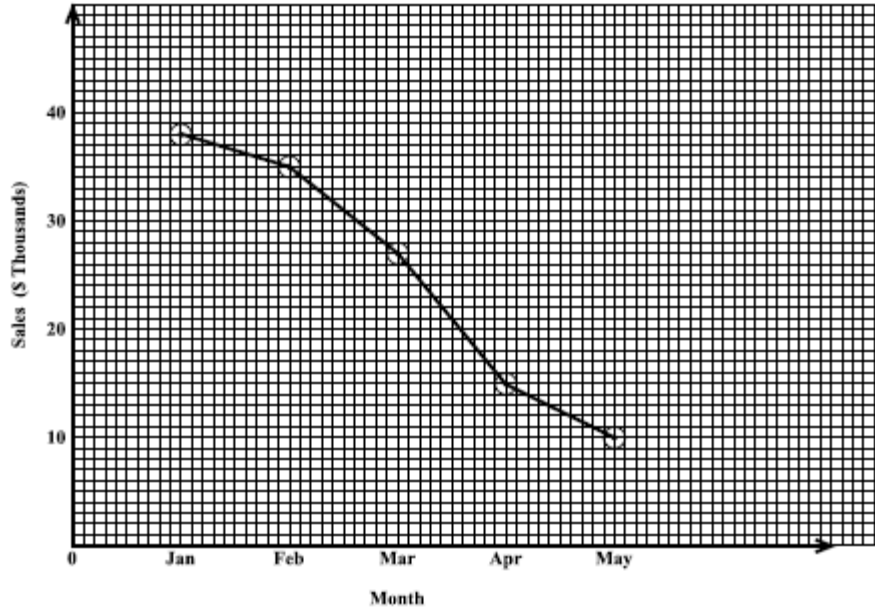

- (i) Copy and complete the table below to show the sales for EACH month.

Month	Jan	Feb	Mar	Apr	May
Sales in \$Thousands	38		27		

(3 marks)

- (ii) Between which TWO consecutive months was there the GREATEST decrease in sales? (1 mark)
- (iii) Calculate the mean monthly sales for the period January to May 2010. (3 marks)
- (iv) The TOTAL sales for the period January to June was \$150 000. Calculate the sales, in dollars, for the month of June. (2 marks)
- (v) Comment on how the sales in June compared with the sales in the previous five months. (2 marks)

Total 11 marks

GO ON TO THE NEXT PAGE

7. An answer sheet is provided for this question.

The diagram below shows triangle RST and its image $R'S'T'$ after a transformation.

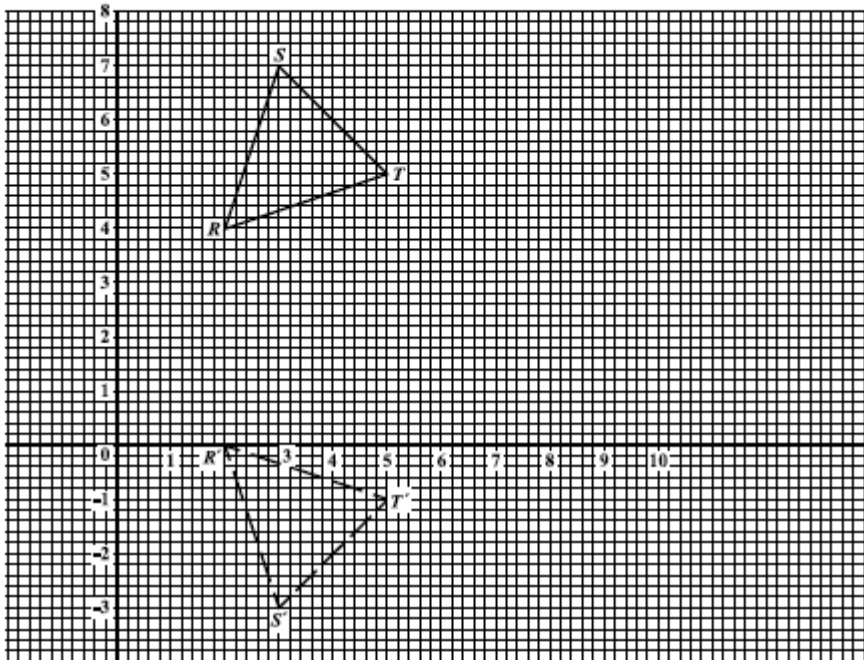

- (i) Write down the coordinates of R and R' . (2 marks)
- (ii) Describe completely the transformation which maps triangle RST onto triangle $R'S'T'$. (3 marks)
- (iii) RST undergoes an enlargement, centre, $(0,4)$, scale factor, 3.
- On your answer sheet, draw triangle $R''S''T''$, the image of triangle RST under the enlargement.
 - Given that the area of triangle RST is 4 square units, calculate the area of triangle $R''S''T''$.
 - State TWO geometrical relationships between triangles RST and $R''S''T''$. (7 marks)

Total 12 marks

GO ON TO THE NEXT PAGE

8. An answer sheet is provided for this question.

The answer sheet shows a rectangle, A , of area 20 square units and perimeter 24 units.

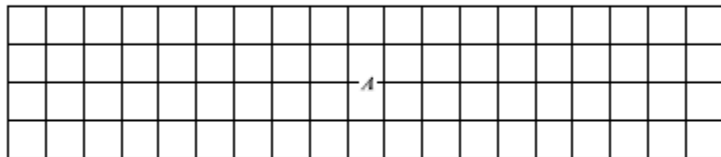

Use the information below to complete the table on the answer sheet, which shows the length, width, area and perimeter of rectangles B , C , D and E .

- (a) On your answer sheet,
- (i) draw and label
 - a) rectangle B of area 27 square units and perimeter 24 units
 - b) rectangle C of area 32 square units and perimeter 24 units. (4 marks)
 - (ii) Complete the table to show the dimensions of rectangles B and C , drawn at (a) (i) above. (2 marks)
- (b) Rectangle D has a perimeter of 24 cm, with length, l , and width, w . If the area of the rectangle D is to be as large as possible, determine the values of l and w . In the table, write the values of l , w and the area of rectangle D . (2 marks)
- (c) Rectangle E has a perimeter of 36 cm, length, l , and width, w . If the area of the rectangle E is to be as large as possible, determine the values of l and w . In the table, write the values of l , w and the area of the rectangle E . (2 marks)

Total 10 marks

GO ON TO THE NEXT PAGE

SECTION II

Answer TWO questions in this section.

ALGEBRA AND RELATIONS, FUNCTIONS AND GRAPHS

9. (a) The functions
- $f(x)$
- and
- $g(x)$
- are defined as:

$$f(x) = \frac{2x-7}{x} \quad \text{and} \quad g(x) = \sqrt{x+3}$$

- (i) Evaluate $f(5)$. (1 mark)
- (ii) Write expressions in x for
- a) $f^{-1}(x)$
- b) $gf(x)$. (6 marks)
- (b) (i) Express the quadratic function $1 - 6x - x^2$, in the form $k - a(x + h)^2$, where a , h and k are constants. (3 marks)
- (ii) Hence state
- a) the maximum value of $1 - 6x - x^2$
- b) the equation of the axis of symmetry of the quadratic function. (2 marks)
- (iii) Determine the roots of $1 - 6x - x^2 = 0$, giving your answers to 2 decimal places. (3 marks)

Total 15 marks

GO ON TO THE NEXT PAGE

MEASUREMENT AND GEOMETRY AND TRIGONOMETRY

10. (a) The diagram, below, not drawn to scale, shows a circle, centre, O . SGH is a tangent to the circle, $\angle FOG = 118^\circ$ and $\angle DGS = 65^\circ$.

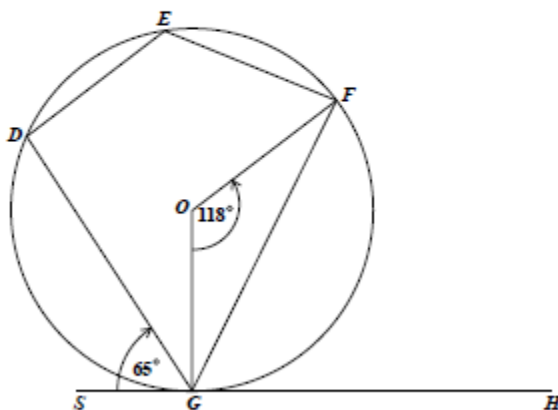

Calculate, giving reasons for EACH step of your answer, the measure of:

- (i) $\angle OGF$ (2 marks)
- (ii) $\angle DEF$ (3 marks)
- (b) J , K and L are three sea ports. A ship began its journey at J , sailed to K , then to L and returned to J .
The bearing of K from J is 054° and L is due east of K .
 $JK = 122$ km and $KL = 60$ km.
- (i) Draw a clearly labelled diagram to represent the above information. Show on the diagram
- the north/south direction
 - the bearing 054°
 - the distances 122 km and 60 km. (3 marks)
- (ii) Calculate
- the measure of angle JKL
 - the distance JL
 - the bearing of J from L . (7 marks)

Total 15 marks

GO ON TO THE NEXT PAGE

VECTORS AND MATRICES

11. (a) Under a matrix transformation, $M = \begin{pmatrix} a & b \\ c & d \end{pmatrix}$, the points, V and W are mapped onto V' and W' such that:

$$\begin{aligned} V(3,5) &\rightarrow V'(5,-3) \\ W(7,2) &\rightarrow W'(2,-7) \end{aligned}$$

- (i) Determine the values of a , b , c and d . (3 marks)
- (ii) State the coordinates of Z such that $Z(x,y) \rightarrow Z'(5,1)$ under the transformation, M . (2 marks)
- (iii) Describe FULLY the geometric transformation, M . (2 marks)
- (b) \vec{OP} and \vec{OR} are position vectors with respect to the origin, O .

P is the point $(2,7)$ and $\vec{PR} = \begin{pmatrix} 4 \\ -3 \end{pmatrix}$.

- (i) Write in the form $\begin{pmatrix} a \\ b \end{pmatrix}$ the vectors:
- a) \vec{OP}
- b) \vec{OR} (3 marks)
- (ii) A point S has coordinates $(14,-2)$.
- a) Find \vec{RS} .
- b) Show that P , R and S are collinear. (5 marks)

Total 15 marks

END OF TEST

FORM TP 2011017



TEST CODE 01234020

JANUARY 2011

CARIBBEAN EXAMINATIONS COUNCIL
SECONDARY EDUCATION CERTIFICATE
EXAMINATION
MATHEMATICS

Paper 02 – General Proficiency

Answer Sheet for Question 7

Candidate Number

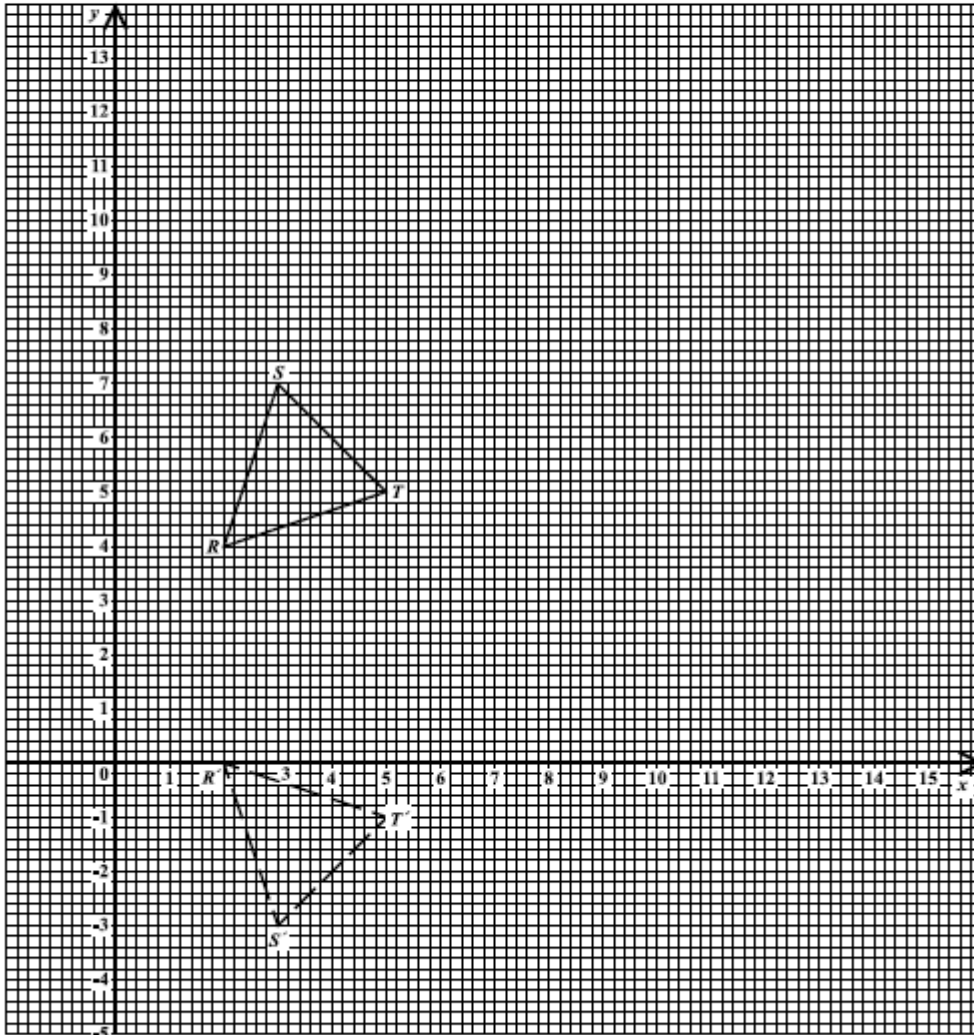

ATTACH THIS ANSWER SHEET TO YOUR ANSWER BOOKLET

FORM TP 2011017



TEST CODE 01234020

JANUARY 2011

CARIBBEAN EXAMINATIONS COUNCIL
SECONDARY EDUCATION CERTIFICATE
EXAMINATION
MATHEMATICS

Paper 02 – General Proficiency

Answer Sheet for Question 8

Candidate Number

Rectangle	Length	Width	Area (square units)	Perimeter (units)
A	10	2	20	24
B	_____	_____	27	24
C	_____	_____	32	24
D	_____	_____	_____	24
E	_____	_____	_____	36

ATTACH THIS ANSWER SHEET TO YOUR ANSWER BOOKLET

FORM TP 2011092



TEST CODE **01234020**

MAY/JUNE 2011

**CARIBBEAN EXAMINATIONS COUNCIL
SECONDARY EDUCATION CERTIFICATE
EXAMINATION
MATHEMATICS**

Paper 02 – General Proficiency

2 hours 40 minutes

18 MAY 2011 (a.m.)

INSTRUCTIONS TO CANDIDATES

1. This paper consists of **TWO** sections.
2. There are **EIGHT** questions in Section I and **THREE** questions in Section II.
3. Answer **ALL** questions in Section I, and any **TWO** questions from Section II.
4. Write your answers in the booklet provided.
5. All working must be clearly shown.
6. A list of formulae is provided on page 2 of this booklet.

Required Examination Materials

Electronic calculator
Geometry set
Graph paper (provided)

DO NOT TURN THIS PAGE UNTIL YOU ARE TOLD TO DO SO.

Copyright © 2009 Caribbean Examinations Council
All rights reserved.

01234020/F 2011

LIST OF FORMULAE

Volume of a prism	$V = Ah$ where A is the area of a cross-section and h is the perpendicular length.
Volume of cylinder	$V = \pi r^2 h$ where r is the radius of the base and h is the perpendicular height.
Volume of a right pyramid	$V = \frac{1}{3}Ah$ where A is the area of the base and h is the perpendicular height.
Circumference	$C = 2\pi r$ where r is the radius of the circle.
Arc length	$S = \frac{\theta}{360} \times 2\pi r$ where θ is the angle subtended by the arc, measured in degrees.
Area of a circle	$A = \pi r^2$ where r is the radius of the circle.
Area of a sector	$A = \frac{\theta}{360} \times \pi r^2$ where θ is the angle of the sector, measured in degrees.
Area of trapezium	$A = \frac{1}{2}(a + b)h$ where a and b are the lengths of the parallel sides and h is the perpendicular distance between the parallel sides.
Roots of quadratic equations	If $ax^2 + bx + c = 0$, then $x = \frac{-b \pm \sqrt{b^2 - 4ac}}{2a}$
Trigonometric ratios	$\sin \theta = \frac{\text{opposite side}}{\text{hypotenuse}}$ $\cos \theta = \frac{\text{adjacent side}}{\text{hypotenuse}}$ $\tan \theta = \frac{\text{opposite side}}{\text{adjacent side}}$
Area of triangle	<p>Area of $\Delta = \frac{1}{2}bh$ where b is the length of the base and h is the perpendicular height</p> <p>Area of $\Delta ABC = \frac{1}{2}ab \sin C$</p> <p>Area of $\Delta ABC = \sqrt{s(s-a)(s-b)(s-c)}$</p> <p>where $s = \frac{a+b+c}{2}$</p>
Sine rule	$\frac{a}{\sin A} = \frac{b}{\sin B} = \frac{c}{\sin C}$
Cosine rule	$a^2 = b^2 + c^2 - 2bc \cos A$

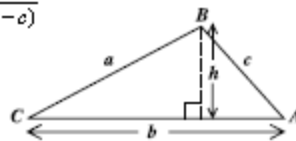
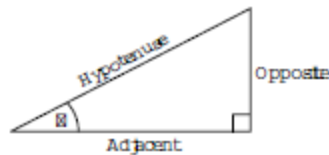

GO ON TO THE NEXT PAGE

SECTION I

Answer ALL the questions in this section.

All working must be clearly shown.

1. (a) Using a calculator, or otherwise, determine the EXACT value of:
- (i) $\frac{2\frac{1}{4} + 1\frac{1}{8}}{4\frac{1}{2}}$ expressing your answer as a fraction (3 marks)
- (ii) $3.96 \times 0.25 - \sqrt{0.0256}$ (3 marks)
- (b) The table below shows Pamela's shopping bill. Some of the information was not included.

Items	Quantity	Unit Price \$	Total Cost \$
Rice	$6\frac{1}{2}$ kg	2.40	\boxed{W}
Potatoes	4 bags	\boxed{X}	52.80
Milk	\boxed{Y} cartons	2.35	14.10
Sub Total			82.50
\boxed{Z} % VAT			9.90
TOTAL			92.40

Calculate the values of W , X , Y and Z . (5 marks)

Total 11 marks

2. (a) Write as a single fraction in its lowest terms

$$\frac{x-2}{3} + \frac{x+1}{4} . \quad (3 \text{ marks})$$

- (b) The binary operation $*$ is defined by

$$a * b = (a + b)^2 - 2ab.$$

Calculate the value of $3 * 4$. (2 marks)

- (c) Factorise completely

(i) $xy^3 + x^2y$ (2 marks)

(ii) $2mh - 2nh - 3mk + 3nk$. (2 marks)

- (d) The table below shows corresponding values of the variables x and y , where y varies directly as x .

x	2	5	b
y	12	a	48

Calculate the values of a and b . (3 marks)

Total 12 marks

3. (a) The Venn diagram below shows the number of students who study Music and Art in a class of 35 students.

U = {students in the class}
 M = {students who study Music}
 A = {students who study Art}

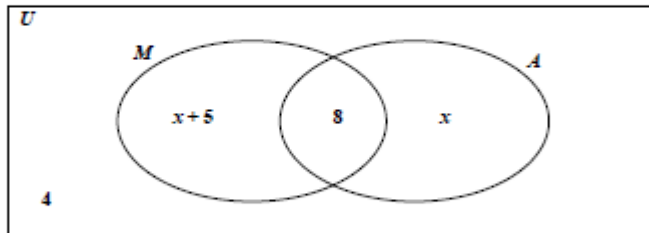

- (i) How many students study neither Art nor Music? (1 mark)
- (ii) Calculate the value of x . (3 marks)
- (iii) Hence, state the number of students who study Music only. (1 mark)
- (b) (i) Using a ruler, pencil, a pair of compasses and a protractor, draw accurately a quadrilateral $EFGH$ using the following measurements:
- $EF = 8 \text{ cm}$ $\angle EFG = 125^\circ$ $FG = 4 \text{ cm}$ $\angle HEF = 70^\circ$ $EH = 7 \text{ cm}$
- (5 marks)
- (ii) Measure and state in centimetres, the length of GH . (1 mark)

Total 11 marks

4. (a) (i) Solve the inequality: $5 - 2x < 9$ (2 marks)
- (ii) If x is an integer, determine the SMALLEST value of x that satisfies the inequality in (a) (i) above. (1 mark)
- (b) In this question, use $\pi = \frac{22}{7}$.
- (i) A piece of wire is bent to form a square of area 121 cm^2 .
- Calculate:
- a) The length of each side of the square
- b) The perimeter of the square (3 marks)
- (ii) The same piece of wire is bent to form a circle.
- Calculate:
- a) The radius of the circle
- b) The area of the circle (4 marks)

Total 10 marks

5. (a) The diagram below, not drawn to scale, shows $\triangle OMN$, and its image, $\triangle OM'N'$ under an enlargement with centre, O , and scale factor, k . Angle $ONM = 90^\circ$.

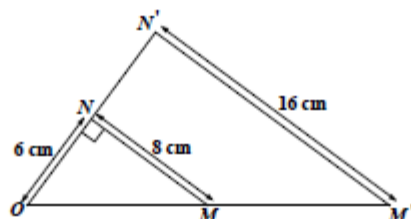

Using the dimensions shown on the diagram, calculate

- the value of k , the scale factor of the enlargement (1 mark)
 - the length of OM (1 mark)
 - the length of OM' . (2 marks)
- (b) The diagram below, not drawn to scale, shows $\triangle PQR$, which represents the cross section of a roof. QS is perpendicular to PSR .

$$PQ = 12.6 \text{ metres} \quad QR = 8.4 \text{ metres} \quad \angle QPR = 15^\circ$$

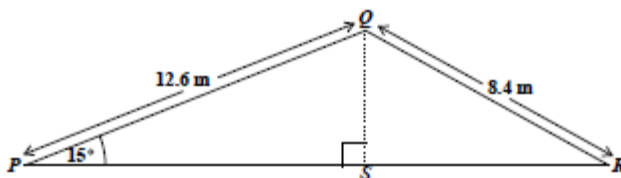

Using the dimensions shown on the diagram, calculate, correct to 3 significant figures

- the length of QS (2 marks)
- the measure of $\angle RQS$ (3 marks)
- the area of $\triangle PQR$. (3 marks)

Total 12 marks

GO ON TO THE NEXT PAGE

6. (a) The functions f and g are defined by

$$f(x) = 6x + 8 \quad ; \quad g(x) = \frac{x-2}{3} .$$

- (i) Calculate the value of $g\left(\frac{1}{2}\right)$. (2 marks)
- (ii) Write an expression for $gf(x)$ in its simplest form. (2 marks)
- (iii) Find the inverse function $f^{-1}(x)$. (2 marks)
- (b) The diagram below shows the line segment which passes through the points A and B .

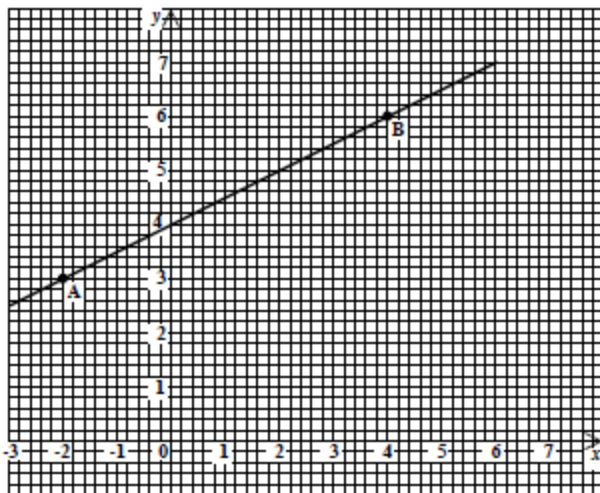

Determine

- (i) the coordinates of A and B (2 marks)
- (ii) the gradient of the line segment AB (2 marks)
- (iii) the equation of the line which passes through A and B . (2 marks)

Total 12 marks

GO ON TO THE NEXT PAGE

7. The table below shows the distribution of the masses of 100 packages.

Mass (kg)	No. of Packages	Cumulative Frequency
1 – 10	12	12
11 – 20	28	40
21 – 30	30	
31 – 40	22	
41 – 50	8	

- (a) Copy and complete the table to show the cumulative frequency for the distribution.
(2 marks)
- (b) Using a scale of 2 cm to represent 10 kg on the x -axis and 1 cm to represent 10 packages on the y -axis, draw the cumulative frequency curve for the data.
(5 marks)
- (c) Estimate from the graph
- the median mass of the packages (2 marks)
 - the probability that a package, chosen at random, has a mass which is LESS than 35 kg. (3 marks)

Total 12 marks

8. An answer sheet is provided for this question.

The figure below shows the first three diagrams in a sequence. Each diagram is made up of sticks joined at the ends by thumb tacks. The sticks are represented by lines and the thumb tacks by dots. In each diagram, there are t thumb tacks and s sticks.

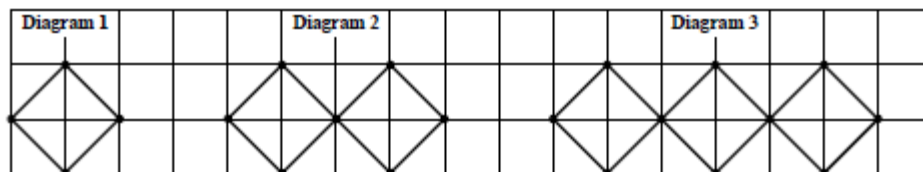

On the answer sheet provided:

- (a) Draw the FOURTH diagram in the sequence. (2 marks)
- (b) (i) How many sticks are in the SIXTH diagram? (1 mark)
- (ii) How many thumb tacks are in the SEVENTH diagram? (1 mark)
- (c) Complete the table by inserting the missing values at the rows marked (i) and (ii).

	No. of Sticks s	Rule Connecting t and s	No. of Thumb Tacks t	
	4	$1 + \left(\frac{3}{4} \times 4\right)$	4	
	8	$1 + \left(\frac{3}{4} \times 8\right)$	7	
	12	$1 + \left(\frac{3}{4} \times 12\right)$	10	
(i)	52	_____	_____	(2 marks)
(ii)	_____	_____	55	(2 marks)

- (d) Write the rule, in terms of s and t , to show how t is related to s . (2 marks)

Total 10 marks

GO ON TO THE NEXT PAGE

SECTION II

Answer TWO questions in this section.

ALGEBRA AND RELATIONS, FUNCTIONS AND GRAPHS

9. (a) Solve the pair of simultaneous equations

$$\begin{aligned} y &= x^2 - x + 3 \\ y &= 6 - 3x \end{aligned} \quad (5 \text{ marks})$$

- (b) (i) Express the function
- $f(x) = 4x^2 - 8x - 2$
- in the form
- $a(x+h)^2 + k$
- , where
- a
- ,
- h
- and
- k
- are constants. (2 marks)

State

- (ii) the minimum value of $f(x)$ (1 mark)
- (iii) the value of x for which $f(x)$ is a minimum. (1 mark)
- (c) The speed-time graph below, not drawn to scale, shows the three-stage journey of a racing car over a period of 60 seconds.

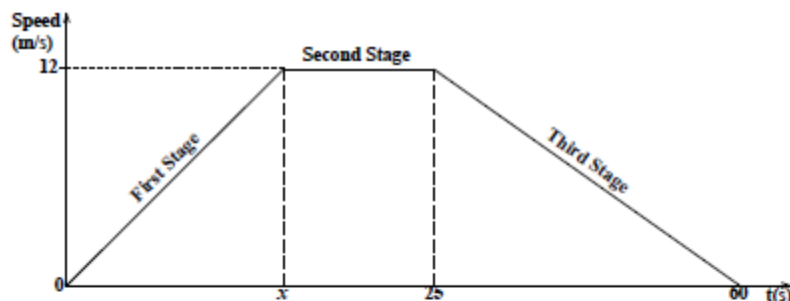

During the FIRST stage of the journey, the car increased its speed from 0 m/s to 12 m/s in x seconds accelerating at 0.6 m/s^2 .

- (i) Calculate the value of x . (2 marks)
- (ii) What is the gradient of the graph during the SECOND stage? Explain, in one sentence, what the car is doing during this stage. (2 marks)
- (iii) Calculate the distance travelled by the car on the THIRD stage of the journey. (2 marks)

Total 15 marks

GO ON TO THE NEXT PAGE

MEASUREMENT, GEOMETRY AND TRIGONOMETRY

10. (a) In the diagram below, not drawn to scale, W, X, Y and Z are points on the circumference of a circle, centre O . TYV is a tangent to the circle at Y , $\angle XWZ = 64^\circ$ and $\angle ZYV = 23^\circ$.

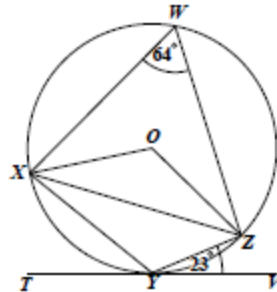

Calculate, giving reasons for your answer, the measure of angle

- (i) $\angle XYZ$ (2 marks)
 (ii) $\angle YXZ$ (2 marks)
 (iii) $\angle OXZ$. (3 marks)
- (b) The diagram below, not drawn to scale, shows the route of an aeroplane flying from Portcity (P) to Queenstown (Q) and then to Riversdale (R). The bearing of Q from P is 132° and the angle PQR is 56° .

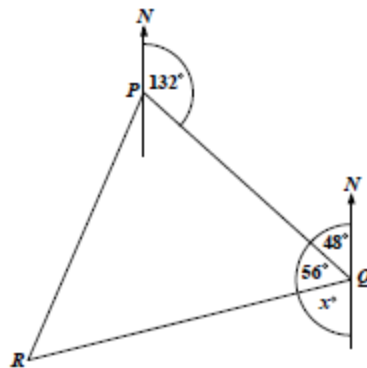

- (i) Calculate the value of x , as shown in the diagram. (2 marks)
 (ii) The distance from Portcity (P) to Queenstown (Q) is 220 kilometres and the distance from Queenstown to Riversdale (R) is 360 kilometres. Calculate the distance RP . (3 marks)
 (iii) Determine the bearing of R from P . (3 marks)

Total 15 marks

GO ON TO THE NEXT PAGE

VECTORS AND MATRICES

11. (a) Determine the inverse of the matrix $\begin{pmatrix} 3 & 5 \\ 2 & 4 \end{pmatrix}$. (2 marks)

(b) The transformation, $M = \begin{pmatrix} 0 & a \\ b & 0 \end{pmatrix}$, maps the points R and T onto R' and T' such that:

$$R(7, 2) \longrightarrow R'(2, -7) \text{ and}$$

$$T(-5, 4) \longrightarrow T'(4, 5)$$

(i) Determine the values of a and b . (2 marks)

(ii) Describe fully the transformation, M . (3 marks)

(c) $WXYZ$ is a parallelogram in which

$$\vec{VY} = a \text{ and } \vec{VW} = b.$$

S is a point on WY such that $WS : SY = 1 : 2$.

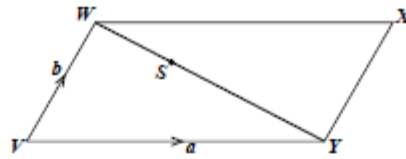

(i) Write in terms of a and b , an expression for:

a) \vec{WY}

b) \vec{WS}

c) \vec{SX}

(5 marks)

(ii) R is the mid-point of VW . Prove that R , S and X are collinear.

(3 marks)

Total 15 marks

END OF TEST



CARIBBEAN EXAMINATIONS COUNCIL
SECONDARY EDUCATION CERTIFICATE
EXAMINATION
MATHEMATICS

Paper 02 – General Proficiency

Answer Sheet for Question 8

Candidate Number

(a)

(b) (i) _____

(ii) _____

(c)

No. of Sticks s	Rule Connecting t and s	No. of Thumb Tacks t
4	$1 + \left(\frac{3}{4} \times 4\right)$	4
8	$1 + \left(\frac{3}{4} \times 8\right)$	7
12	$1 + \left(\frac{3}{4} \times 12\right)$	10
(i) 52	_____	_____
(ii) _____	_____	55

(d) _____

ATTACH THIS ANSWER SHEET TO YOUR ANSWER BOOKLET

FORM TP 2012017



TEST CODE **01234020**

JANUARY 2012

CARIBBEAN EXAMINATIONS COUNCIL
SECONDARY EDUCATION CERTIFICATE
EXAMINATION
MATHEMATICS

Paper 02 – General Proficiency

2 hours 40 minutes

04 JANUARY 2012 (a.m.)

READ THE FOLLOWING INSTRUCTIONS CAREFULLY.

1. This paper consists of **TWO** sections.
2. There are **EIGHT** questions in Section I and **THREE** questions in Section II.
3. Answer **ALL** questions in Section I, and any **TWO** questions from Section II.
4. Write your answers in the booklet provided.
5. All working must be clearly shown.
6. A list of formulae is provided on page 2 of this booklet.

Required Examination Materials

Electronic calculator
Geometry set
Graph paper (provided)

DO NOT TURN THIS PAGE UNTIL YOU ARE TOLD TO DO SO.

Copyright © 2009 Caribbean Examinations Council
All rights reserved.

01234020/JANUARY/F 2012

LIST OF FORMULAE

Volume of a prism	$V = Ah$ where A is the area of a cross-section and h is the perpendicular length.
Volume of cylinder	$V = \pi r^2 h$ where r is the radius of the base and h is the perpendicular height.
Volume of a right pyramid	$V = \frac{1}{3}Ah$ where A is the area of the base and h is the perpendicular height.
Circumference	$C = 2\pi r$ where r is the radius of the circle.
Arc length	$S = \frac{\theta}{360} \times 2\pi r$ where θ is the angle subtended by the arc, measured in degrees.
Area of a circle	$A = \pi r^2$ where r is the radius of the circle.
Area of a sector	$A = \frac{\theta}{360} \times \pi r^2$ where θ is the angle of the sector, measured in degrees.
Area of trapezium	$A = \frac{1}{2}(a + b)h$ where a and b are the lengths of the parallel sides and h is the perpendicular distance between the parallel sides.
Roots of quadratic equations	If $ax^2 + bx + c = 0$, then $x = \frac{-b \pm \sqrt{b^2 - 4ac}}{2a}$
Trigonometric ratios	$\sin \theta = \frac{\text{opposite side}}{\text{hypotenuse}}$ $\cos \theta = \frac{\text{adjacent side}}{\text{hypotenuse}}$ $\tan \theta = \frac{\text{opposite side}}{\text{adjacent side}}$
Area of triangle	<p>Area of $\Delta = \frac{1}{2}bh$ where b is the length of the base and h is the perpendicular height.</p> <p>Area of $\Delta ABC = \frac{1}{2}ab \sin C$</p> <p>Area of $\Delta ABC = \sqrt{s(s-a)(s-b)(s-c)}$</p> <p>where $s = \frac{a + b + c}{2}$</p>
Sine rule	$\frac{a}{\sin A} = \frac{b}{\sin B} = \frac{c}{\sin C}$
Cosine rule	$a^2 = b^2 + c^2 - 2bc \cos A$

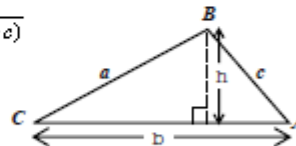
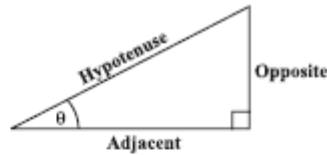

GO ON TO THE NEXT PAGE

SECTION I

Answer ALL the questions in this section.

All working must be clearly shown.

1. (a) Using a calculator, or otherwise, calculate the EXACT value of
- (i) $\left(1\frac{3}{4}\right)^2 \div 3\frac{1}{2}$, expressing your answer as a fraction (3 marks)
- (ii) $\sqrt{0.0529} + 0.216$, expressing your answer in standard form. (3 marks)
- (b) A typist is paid a basic wage of \$22.50 per hour for a 40-hour week.
- (i) Calculate the typist's basic weekly wage. (1 mark)
- Overtime is paid at one and a half times the basic hourly rate.
- (ii) Calculate the overtime wage for ONE hour of overtime work. (1 mark)
- To earn some extra money, the typist decided to work overtime.
- Calculate
- (iii) the wage she would earn for overtime if she worked for a TOTAL of 52 hours during a given week. (2 marks)
- (iv) the number of overtime hours she must work during a given week to earn a TOTAL wage of \$1440. (2 marks)

Total 12 marks

GO ON TO THE NEXT PAGE

2. (a) Solve the pair of simultaneous equations

$$\begin{aligned} 3x + 2y &= 13 \\ x - 2y &= -1. \end{aligned}$$

(3 marks)

- (b) Factorise completely

(i) $x^2 - 16$

(1 mark)

(ii) $2x^2 - 3x + 8x - 12.$

(2 marks)

- (c) Tickets for a football match are sold at \$30 for EACH adult and \$15 for EACH child. A company bought 28 tickets.

- (i) If x of these tickets were for adults, write in terms of x ,

a) the number of tickets for children

(1 mark)

b) the amount spent on tickets for adults

(1 mark)

c) the amount spent on tickets for children.

(1 mark)

- (ii) Show that the TOTAL amount spent on the 28 tickets is $\$(15x + 420)$.

(1 mark)

- (iii) Given that the cost of the 28 tickets was \$660, calculate the number of adult tickets bought by the company.

(2 marks)

Total 12 marks

3. (a) A universal set, U , is defined as:

$$U = \{ 51, 52, 53, 54, 55, 56, 57, 58, 59 \}$$

A and B are subsets of U , such that:

$$A = \{ \text{odd numbers} \}$$

$$B = \{ \text{prime numbers} \}$$

- (i) List the members of the set A .

(1 mark)

- (ii) List the members of the set B .

(1 mark)

- (iii) Draw a Venn diagram to represent the sets A , B and U .

(3 marks)

- (b) (i) Using a pair of compasses, a ruler and a pencil

a) construct a triangle CDE in which $DE = 10$ cm, $DC = 8$ cm and $\angle CDE = 45^\circ$.

(4 marks)

b) construct a line, CF , perpendicular to DE such that F lies on DE .

(2 marks)

- (ii) Using a protractor, measure and state the size of $\angle DCE$.

(1 mark)

Total 12 marks

GO ON TO THE NEXT PAGE

4. (a) The following is an extract from a bus schedule. The bus begins its journey at Belleview, travels to Chagville and ends its journey at St. Andrews.

Town	Arrive	Depart
Belleview	—	6:40 a.m.
Chagville	7:35 a.m.	7:45 a.m.
St. Andrews	8:00 a.m.	—

- (i) How long did the bus spend at Chagville? (1 mark)
- (ii) How long did the bus take to travel from Belleview to Chagville? (1 mark)
- (iii) The bus travelled at an average speed of 54 km/hour from Belleview to Chagville. Calculate, in kilometres, the distance from Belleview to Chagville. (2 marks)
- (b) Water is poured into a cylindrical bucket with a base area of 300 cm^2 . If 4.8 litres of water was poured into the bucket, what is the height of the water in the bucket? (3 marks)
- (c) The diagram below, **not drawn to scale**, shows a cuboid with length 13 cm, width 4 cm and height h cm.

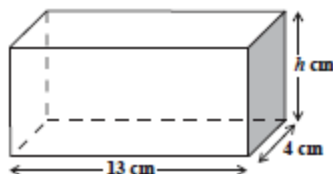

- (i) State, in terms of h , the area of the shaded face of the cuboid. (1 mark)
- (ii) Write an expression, in terms of h , for the volume of the cuboid. (1 mark)
- (iii) If the volume of the cuboid is 286 cm^3 calculate the height, h , of the cuboid. (2 marks)

Total 11 marks

GO ON TO THE NEXT PAGE

5. (a) The diagram below, not drawn to scale, shows TWO triangles, JKL and MLP , with JK parallel to ML . $LM = MP$, KLP is a straight line, angle $JLM = 22^\circ$ and angle $LMP = 36^\circ$.

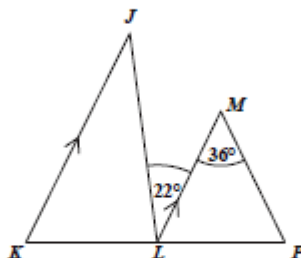

Calculate, giving reasons for your answers, the measure of EACH of the following:

- (i) $\angle MLP$
- (ii) $\angle LJK$
- (iii) $\angle JKL$
- (iv) $\angle KLJ$ (4 marks)

- (b) The diagram below shows a triangle, PQR , and its image, $P'Q'R'$.

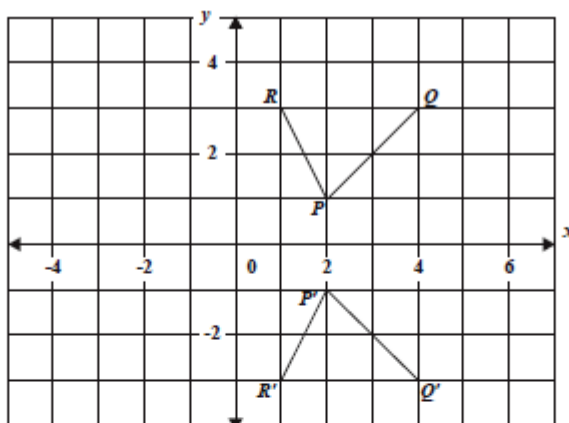

- (i) State the coordinates of P and Q . (2 marks)
- (ii) Describe fully the transformation that maps triangle PQR onto triangle $P'Q'R'$. (2 marks)
- (iii) Write down the coordinates of the images of P and Q under the translation

$$\begin{pmatrix} 3 \\ -6 \end{pmatrix}$$

(2 marks)

Total 10 marks

GO ON TO THE NEXT PAGE

6. The table below shows corresponding values of x and y for the function $y = x^2 - 2x - 3$, for integer values of x from -2 to 4 .

x	-2	-1	0	1	2	3	4
y	5		-3	-4		0	5

- (a) Copy and complete the table. (2 marks)
- (b) Using a scale of **2 cm** to represent **1 unit** on the x -axis, and **1 cm** to represent **1 unit** on the y -axis, plot the points whose x and y values are recorded in your table, and draw a smooth curve through your points. (4 marks)
- (c) Using your graph, estimate the value of y when $x = 3.5$. Show on your graph how the value was obtained. (2 marks)
- (d) Without further calculations,
- write the equation of the axis of symmetry of the graph (1 mark)
 - estimate the minimum value of the function y (1 mark)
 - state the values of the solutions of the equation: $x^2 - 2x - 3 = 0$. (1 mark)

Total 11 marks

GO ON TO THE NEXT PAGE

7. The histogram below shows the distribution of heights of seedlings in a sample.

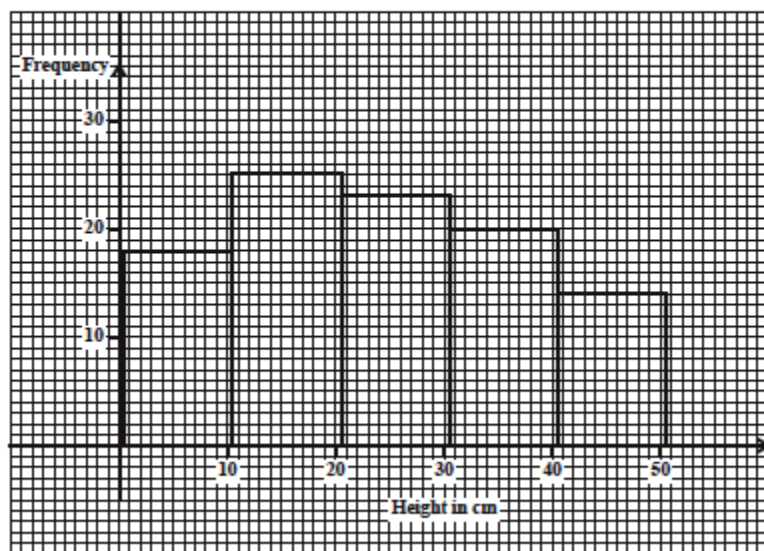

- (a) Copy and complete the frequency table for the data in the sample.

Height in cm	Mid-point	Frequency
1 - 10	5.5	18
11 - 20	15.5	25
21 - 30		
31 - 40		
41 - 50		

(3 marks)

- (b) Determine

- (i) the modal class interval (1 mark)
- (ii) the number of seedlings in the sample (2 marks)
- (iii) the mean height of the seedlings (4 marks)
- (iv) the probability that a seedling chosen at random has a height that is GREATER than 30 cm. (2 marks)

Total 12 marks

GO ON TO THE NEXT PAGE

8. An answer sheet is provided for this question.

Sarah is making a pattern of squares using straws. She uses four straws for the sides and two longer straws for the diagonals. The first three figures in her sequence of shapes are shown below:



Figure 1



Figure 2



Figure 3

- (a) On your answer sheet, draw Figure 4, the FOURTH shape in the pattern. (2 marks)
- (b) On your answer sheet, complete the TWO rows in the table for
- (i) Figure 4
- (ii) Figure 10.

		Total Number of Straws	
Figure	Formula	Number	
1	$1(6) - 0$	6	
2	$2(6) - 1$	11	
3	$3(6) - 2$	16	
(i) 4			
(ii) 10			

(4 marks)

- (c) Which figure in the sequence uses 106 straws? (2 marks)
- (d) Obtain an expression in n , for the total number of straws used in the n^{th} pattern. (2 marks)

Total 10 marks

GO ON TO THE NEXT PAGE

SECTION II

Answer TWO questions in this section.

ALGEBRA AND RELATIONS, FUNCTIONS AND GRAPHS

9. (a) (i) Make
- x
- the subject of the formula

$$y = \frac{2x+3}{x-4} \quad (2 \text{ marks})$$

- (ii) Hence, determine the inverse of $f(x) = \frac{2x+3}{x-4}$, where $x \neq 4$. (2 marks)
- (iii) Find the value of x for which $f(x) = 0$. (2 marks)

- (b) The diagram below shows the graphs of three lines and a shaded region defined by three inequalities associated with these lines.

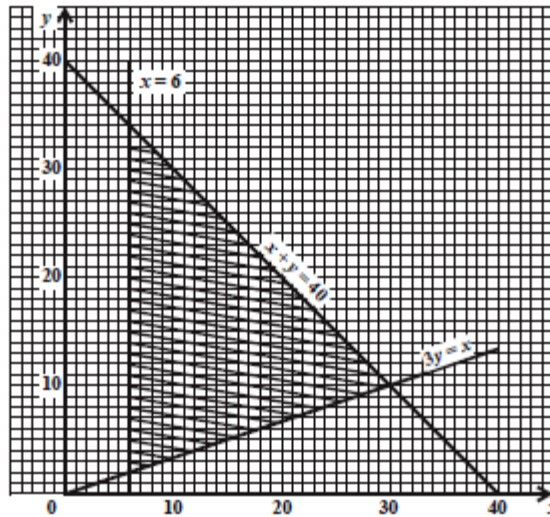
The inequality associated with the line $3y = x$ is $3y \geq x$.

- (i) State the other TWO inequalities which define the shaded region. (2 marks)

The function $p = 4x + 3y$ satisfies the solution set represented by the closed triangular region.

- (ii) Identify the three pairs of (x, y) values for which p has a maximum or a minimum value. (3 marks)
- (iii) Which pair of (x, y) values makes p a maximum? Justify your answer. (4 marks)

Total 15 marks

GO ON TO THE NEXT PAGE

MEASUREMENT, GEOMETRY AND TRIGONOMETRY

10. (a) The diagram below, not drawn to scale, shows a regular hexagon with centre, O , and $AO = 5$ cm.

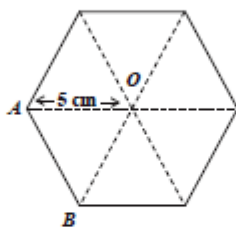

- (i) Determine the size of angle AOB . (2 marks)
- (ii) Calculate, to the nearest whole number, the area of the hexagon. (3 marks)
- (b) The diagram below, not drawn to scale, shows a vertical pole, PL , standing on a horizontal plane, KLM . The angle of elevation of P from K is 28° , $KL = 15$ m, $LM = 19$ m and $\angle KLM = 115^\circ$.

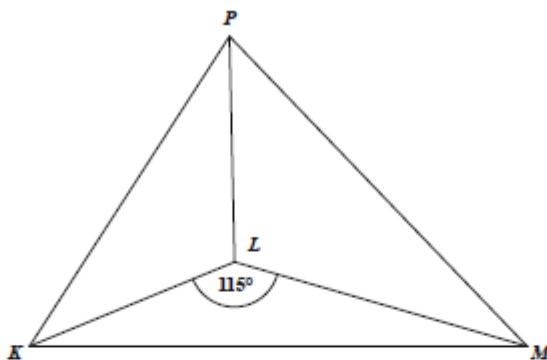

- (i) Copy the diagram. Show the angle of elevation, 28° and ONE right angle. (2 marks)
- (ii) Calculate, giving your answer to 2 significant figures, the measure of
- a) PL (2 marks)
- b) KM (3 marks)
- c) the angle of elevation of P from M . (3 marks)

Total 15 marks

GO ON TO THE NEXT PAGE

11. (a) The diagram below shows two position vectors \vec{OA} and \vec{OB} .

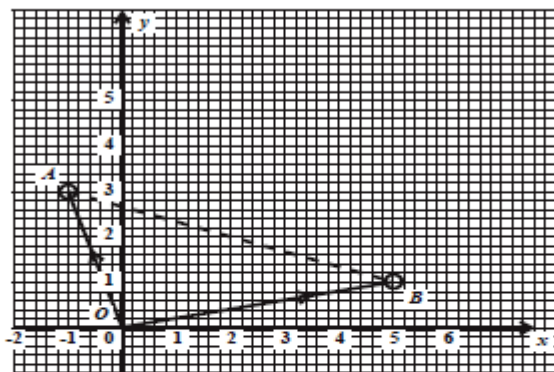

- (i) Write as a column vector, in the form $\begin{pmatrix} x \\ y \end{pmatrix}$:
- a) \vec{OA} (1 mark)
- b) \vec{OB} (1 mark)
- c) \vec{BA} (2 marks)
- (ii) Given that G is the mid-point of the line AB , write as a column vector in the form $\begin{pmatrix} x \\ y \end{pmatrix}$:
- a) \vec{BG} (1 mark)
- b) \vec{OG} (1 mark)
- (b) L and M are two matrices where
 $L = \begin{pmatrix} 3 & 2 \\ 1 & 4 \end{pmatrix}$ and $M = \begin{pmatrix} -1 & 3 \\ 0 & 2 \end{pmatrix}$.
- Evaluate
- (i) $L + 2M$ (2 marks)
- (ii) LM (2 marks)
- (c) The matrix, Q , is such that $Q = \begin{pmatrix} 4 & 2 \\ 1 & 1 \end{pmatrix}$.
- (i) Find Q^{-1} . (2 marks)
- (ii) Using a matrix method, find the values of x and y in the equation
 $\begin{pmatrix} 4 & 2 \\ 1 & 1 \end{pmatrix} \begin{pmatrix} x \\ y \end{pmatrix} = \begin{pmatrix} 8 \\ 3 \end{pmatrix}$. (3 marks)

Total 15 marks

END OF TEST

IF YOU FINISH BEFORE TIME IS CALLED, CHECK YOUR WORK ON THIS TEST.

01234020/JANUARY/F 2012



CARIBBEAN EXAMINATIONS COUNCIL
SECONDARY EDUCATION CERTIFICATE
EXAMINATION
MATHEMATICS

Paper 02 – General Proficiency

Answer Sheet for Question 8

Candidate Number

(a) Draw the FOURTH shape in the pattern:

(b) Complete the table for Figure 4 and Figure 10.

		Total Number of Straws	
	Figure	Formula	Number
	1	$1(6) - 0$	6
	2	$2(6) - 1$	11
	3	$3(6) - 2$	16
(i)	4		
(ii)	10		

(c) Which figure in the sequence uses 106 straws?

(d) Obtain an expression in n , for the total number of straws used in the n^{th} pattern.

ATTACH THIS ANSWER SHEET TO YOUR ANSWER BOOKLET



TEST CODE **01234020**

FORM TP 2012092

MAY/JUNE 2012

**CARIBBEAN EXAMINATIONS COUNCIL
SECONDARY EDUCATION CERTIFICATE
EXAMINATION
MATHEMATICS**

Paper 02 – General Proficiency

2 hours 40 minutes

18 MAY 2012 (a.m.)

READ THE FOLLOWING INSTRUCTIONS CAREFULLY.

1. This paper consists of **TWO** sections.
2. There are **EIGHT** questions in Section I and **THREE** questions in Section II.
3. Answer **ALL** questions in Section I, and any **TWO** questions from Section II.
4. Write your answers in the booklet provided.
5. All working must be shown clearly.
6. A list of formulae is provided on page 2 of this booklet.

Required Examination Materials

Electronic calculator
Geometry set
Graph paper (provided)

DO NOT TURN THIS PAGE UNTIL YOU ARE TOLD TO DO SO.

Copyright © 2010 Caribbean Examinations Council
All rights reserved.

01234020/F 2012

LIST OF FORMULAE

Volume of a prism	$V = Ah$ where A is the area of a cross-section and h is the perpendicular length.
Volume of cylinder	$V = \pi r^2 h$ where r is the radius of the base and h is the perpendicular height.
Volume of a right pyramid	$V = \frac{1}{3}Ah$ where A is the area of the base and h is the perpendicular height.
Circumference	$C = 2\pi r$ where r is the radius of the circle.
Arc length	$S = \frac{\theta}{360} \times 2\pi r$ where θ is the angle subtended by the arc, measured in degrees
Area of a circle	$A = \pi r^2$ where r is the radius of the circle.
Area of a sector	$A = \frac{\theta}{360} \times \pi r^2$ where θ is the angle of the sector, measured in degrees.
Area of trapezium	$A = \frac{1}{2}(a + b)h$ where a and b are the lengths of the parallel sides and h is the perpendicular distance between the parallel sides.
Roots of quadratic equations	If $ax^2 + bx + c = 0$, then $x = \frac{-b \pm \sqrt{b^2 - 4ac}}{2a}$
Trigonometric ratios	$\sin \theta = \frac{\text{opposite side}}{\text{hypotenuse}}$ $\cos \theta = \frac{\text{adjacent side}}{\text{hypotenuse}}$ $\tan \theta = \frac{\text{opposite side}}{\text{adjacent side}}$
Area of triangle	<p>Area of $\Delta = \frac{1}{2}bh$ where b is the length of the base and h is the perpendicular height.</p> <p>Area of $\Delta ABC = \frac{1}{2}ab \sin C$</p> <p>Area of $\Delta ABC = \sqrt{s(s-a)(s-b)(s-c)}$</p> <p>where $s = \frac{a+b+c}{2}$</p>
Sine rule	$\frac{a}{\sin A} = \frac{b}{\sin B} = \frac{c}{\sin C}$
Cosine rule	$a^2 = b^2 + c^2 - 2bc \cos A$

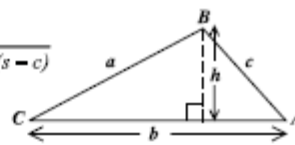
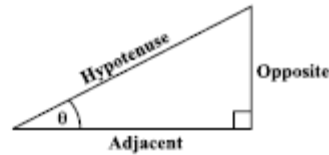

GO ON TO THE NEXT PAGE

SECTION I

Answer ALL the questions in this section.

All working must be clearly shown.

1. (a) Calculate the EXACT value of

$$\frac{3\frac{1}{5} - \frac{2}{3}}{2\frac{4}{5}}$$

giving your answer as a fraction in its lowest terms.

(3 marks)

- (b) The table below shows the cost price, selling price and profit or loss as a percentage of the cost price.

Copy and complete the table below, inserting the missing values at (i) and (ii).

	Cost Price	Selling Price	Percentage Profit or Loss
(i)	\$55.00	\$44.00	_____
(ii)	_____	\$100.00	25% profit

(4 marks)

- (c) The table below shows some rates of exchange:

US \$1.00 = EC \$2.70
TT \$1.00 = EC \$0.40

Calculate the value of

- (i) EC \$1 in TT \$ (1 mark)
- (ii) US \$80 in EC \$ (1 mark)
- (iii) TT \$648 in US \$. (3 marks)

Total 12 marks

GO ON TO THE NEXT PAGE

2. (a) Factorise completely:

(i) $2x^2y + 6x^2y^2$ (2 marks)

(ii) $9x^2 - 4$ (1 mark)

(iii) $4x^2 + 8xy - xy^2 - 2y^2$ (2 marks)

- (b) Solve for x :

$$\frac{2x - 3}{3} + \frac{5 - x}{2} = 3 \quad (3 \text{ marks})$$

- (c) Solve the simultaneous equations:

$$\begin{aligned} 3x - 2y &= 10 \\ 2x + 5y &= 13 \end{aligned} \quad (4 \text{ marks})$$

Total 12 marks

3. (a) In a survey of 36 students, it was found that
 30 play tennis,
 x play volleyball ONLY,
 $9x$ play BOTH tennis and volleyball
 4 play neither tennis nor volleyball.

- (i) Given that:

$U = \{\text{students in the survey}\}$

$V = \{\text{students who play Volleyball}\}$

$T = \{\text{students who play Tennis}\}$

Copy and complete the Venn diagram below to show the number of students in the subsets marked y and z .

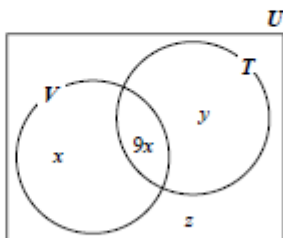

(2 marks)

GO ON TO THE NEXT PAGE

- (ii) a) Write an expression in x to represent the TOTAL number of students in the survey. (1 mark)
- b) Write an equation in x to represent the total number of students in the survey and hence solve for x . (2 marks)
- (b) The diagram below, not drawn to scale, shows the journey of a ship which started at port P , sailed 15 km due south to port Q , and then a further 20 km due west to port R .

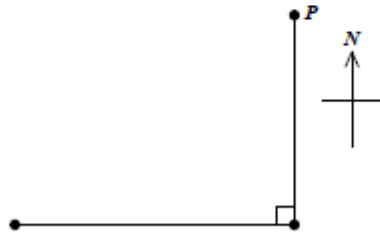

- (i) Copy the diagram and label it to show the points Q and R , and the distances 20 km and 15 km. (2 marks)
- (ii) Calculate PR , the shortest distance of the ship from the port where the journey started. (2 marks)
- (iii) Calculate the measure of angle QPR , giving your answer to the nearest degree. (3 marks)

Total 12 marks

GO ON TO THE NEXT PAGE

4. The diagram below, not drawn to scale, shows the cross section of a prism in the shape of a sector of a circle, centre O , and radius 3.5 cm. The angle at the centre is 270° .

Use $\pi = \frac{22}{7}$

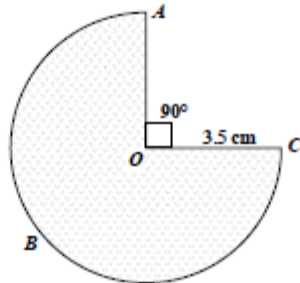

- (a) Calculate
- the length of the arc ABC (2 marks)
 - the perimeter of the sector OAC (2 marks)
 - the area of the sector OAC . (2 marks)
- (b) The prism is 20 cm long and is a solid made of tin. Calculate
- the volume of the prism (2 marks)
 - the mass of the prism, to the nearest kg, given that 1 cm^3 of tin has a mass of 7.3 kg. (2 marks)

Total 10 marks

5. (a) (i) Using a ruler, a pencil and a pair of compasses, construct triangle PQR with $PQ = 8$ cm, $\angle PQR = 60^\circ$ and $\angle QPR = 45^\circ$. (4 marks)
- (ii) Measure and state the length of RQ . (1 mark)
- (b) The line ℓ passes through the points $S(6, 6)$ and $T(0, -2)$.
- Determine
- (i) the gradient of the line, ℓ (2 marks)
- (ii) the equation of the line, ℓ (2 marks)
- (iii) the midpoint of the line segment, TS (1 mark)
- (iv) the length of the line segment, TS . (2 marks)

Total 12 marks

6. An answer sheet is provided for this question.

The graph below shows triangle LMN and its image PQR after an enlargement.

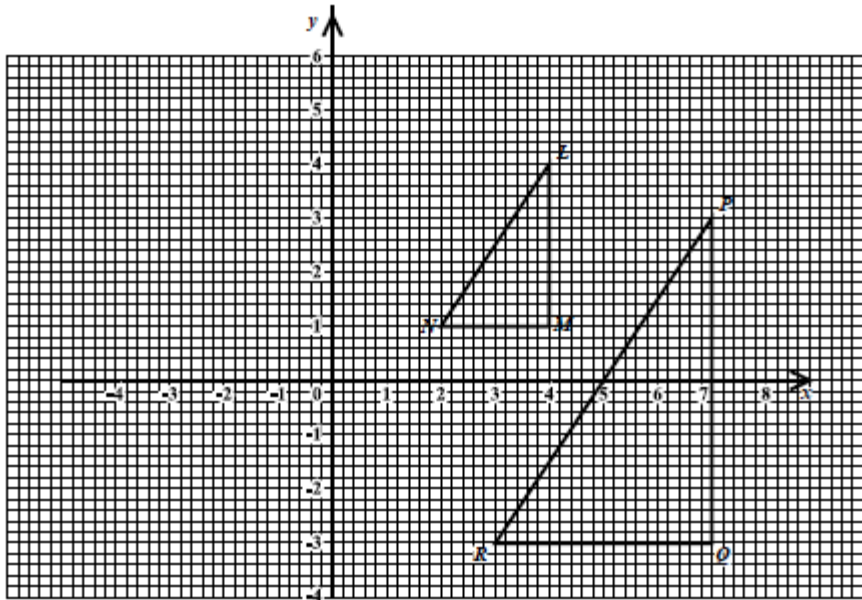

On the answer sheet provided

- Locate the centre of enlargement, showing your method clearly. (2 marks)
- State the scale factor and the coordinates of the centre of the enlargement. (2 marks)
- Determine the value of $\frac{\text{Area of } PQR}{\text{Area of } LMN}$. (2 marks)
- Draw and label triangle ABC with coordinates $(-4, 4)$, $(-1, 4)$ and $(-1, 2)$ respectively. (2 marks)
- Describe fully the single transformation which maps triangle LMN on to triangle ABC . (3 marks)

Total 11 marks

GO ON TO THE NEXT PAGE

7. The table below shows the ages, to the nearest year, of the persons who visited the clinic during a particular week.

Age (yrs)	Number of persons	Cumulative Frequency
40 – 49	4	4
50 – 59	11	15
60 – 69	20	—
70 – 79	12	—
80 – 89	3	50

- (a) Copy and complete the table to show the cumulative frequency. (2 marks)
- (b) Using a scale of 2 cm to represent 10 years on the x -axis and 1 cm to represent 5 persons on the y -axis, draw the cumulative frequency curve for the data. (5 marks)
- (c) Use your graph drawn at (b) above to estimate
- the median age for the data (2 marks)
 - the probability that a person who visited the clinic was 75 years or younger. (2 marks)

Draw lines on your graph to show how these estimates were obtained.

Total 11 marks

8. An answer sheet is provided for this question.

The diagram below shows the first three figures in a sequence of figures. Each figure is an isosceles triangle made of a rubber band stretched around pins on a geo-board. The pins are arranged in rows and columns, one unit apart.

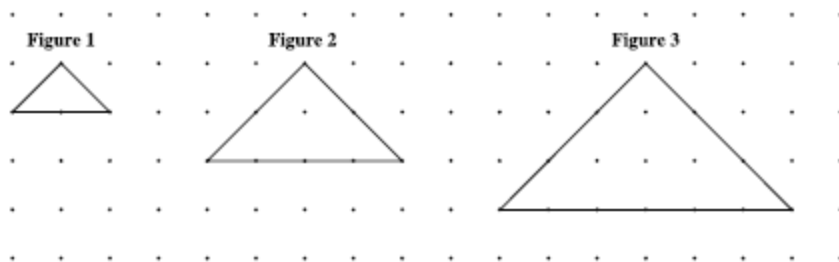

- (a) On the answer sheet provided, draw the fourth figure (Figure 4) in the sequence. (2 marks)
- (b) Study the patterns in the table below, and on your answer sheet, complete the rows numbered (i), (ii), (iii) and (iv). The breaks in the columns are to indicate that the rows do not follow one after the other.

	Figure	Area of Triangle	No. of Pins on Base	
	1	1	$2 \times 1 + 1 = 3$	
	2	4	$2 \times 2 + 1 = 5$	
	3	9	$2 \times 3 + 1 = 7$	
(i)	4	_____	_____	(2 marks)
(ii)	___	100	_____	(2 marks)
(iii)	20	_____	_____	(2 marks)
(iv)	n	_____	_____	(2 marks)

Total 10 marks

SECTION II

There are **THREE** questions in this section.

Answer **TWO** questions in this section

ALGEBRA AND RELATIONS, FUNCTIONS AND GRAPHS

9. (a) (i) Solve the pair of simultaneous equations:
- $$y = 8 - x$$
- $$2x^2 + xy = -16 \quad (5 \text{ marks})$$
- (ii) State, giving the reason for your answer, whether the line $y = 8 - x$ is a tangent to the curve $2x^2 + xy = -16$. (2 marks)
- (b) An answer sheet is provided for this question.

A florist makes bouquets of flowers, each consisting of x roses and y orchids. For each bouquet, she applies the following constraints:

- the number of orchids must be at least half the number of roses
 - there must be at least 2 roses
 - there must be no more than 12 flowers
- (i) Write **THREE** inequalities for the constraints given. (3 marks)
- (ii) On the answer sheet provided, shade the region of the graph which represents the solution set for the inequalities in (b) (i). (1 mark)
- (iii) State the coordinates of the points which represent the vertices of the region showing the solution set. (1 mark)
- (iv) The florist sells a bouquet of flowers to make a profit of \$3 on each rose and \$4 on each orchid. Determine the **MAXIMUM** possible profit on the sale of a bouquet. (3 marks)

Total 15 marks

GO ON TO THE NEXT PAGE

MEASUREMENT, GEOMETRY AND TRIGONOMETRY

10. (a) The diagram below, not drawn to scale, shows a quadrilateral $QRST$ in which $QS = 7$ cm, $ST = 10$ cm, $QT = 8$ cm, $\angle SRQ = 60^\circ$ and $\angle RQS = 48^\circ$.

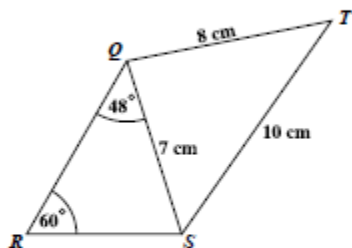

Calculate

- the length of RS (3 marks)
 - the measure of $\angle QTS$. (3 marks)
- (b) The diagram below, not drawn to scale, shows a circle, centre O . The line UVW is a tangent to the circle, $ZOXW$ is a straight line and angle $UOX = 70^\circ$.

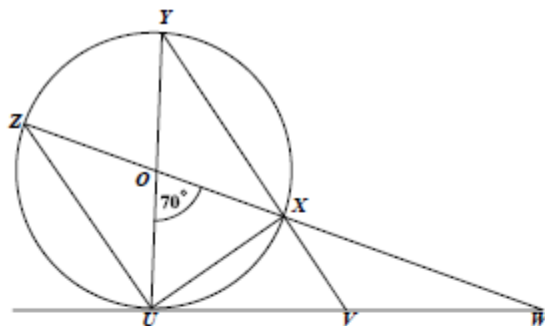

- Calculate, showing working where necessary, the measure of angle
 - $\angle OUZ$ (2 marks)
 - $\angle UVY$ (3 marks)
 - $\angle UWO$. (2 marks)
- Name the triangle in the diagram which is congruent to triangle
 - $\triangle ZOU$ (1 mark)
 - $\triangle YXU$. (1 mark)

Total 15 marks

GO ON TO THE NEXT PAGE

VECTORS AND MATRICES

11. (a) The points A , B and C have position vectors $\vec{OA} = \begin{pmatrix} 6 \\ 2 \end{pmatrix}$, $\vec{OB} = \begin{pmatrix} 3 \\ 4 \end{pmatrix}$ and $\vec{OC} = \begin{pmatrix} 12 \\ -2 \end{pmatrix}$ respectively.
- (i) Express in the form $\begin{pmatrix} x \\ y \end{pmatrix}$ the vector
- a) \vec{BA} (2 marks)
- b) \vec{BC} . (2 marks)
- (ii) State ONE geometrical relationship between BA and BC . (1 mark)
- (iii) Draw a sketch to show the relative positions of A , B and C . (2 marks)
- (b) (i) Calculate the values of a and b such that $\begin{pmatrix} a & -4 \\ 1 & b \end{pmatrix} \begin{pmatrix} 2 & -4 \\ 1 & -3 \end{pmatrix} = \begin{pmatrix} 2 & 0 \\ 0 & 2 \end{pmatrix}$. (3 marks)
- (ii) Hence, or otherwise, write down the inverse of $\begin{pmatrix} 2 & -4 \\ 1 & -3 \end{pmatrix}$. (2 marks)
- (iii) Use the inverse of $\begin{pmatrix} 2 & -4 \\ 1 & -3 \end{pmatrix}$ to solve for x and y in the matrix equation
- $$\begin{pmatrix} 2 & -4 \\ 1 & -3 \end{pmatrix} \begin{pmatrix} x \\ y \end{pmatrix} = \begin{pmatrix} 12 \\ 7 \end{pmatrix}. \quad (3 \text{ marks})$$
- Total 15 marks**

END OF TEST

IF YOU FINISH BEFORE TIME IS CALLED, CHECK YOUR WORK ON THIS TEST.



CARIBBEAN EXAMINATIONS COUNCIL
 SECONDARY EDUCATION CERTIFICATE
 EXAMINATION
 MATHEMATICS

Paper 02 – General Proficiency

Answer Sheet for Question 6

Candidate Number

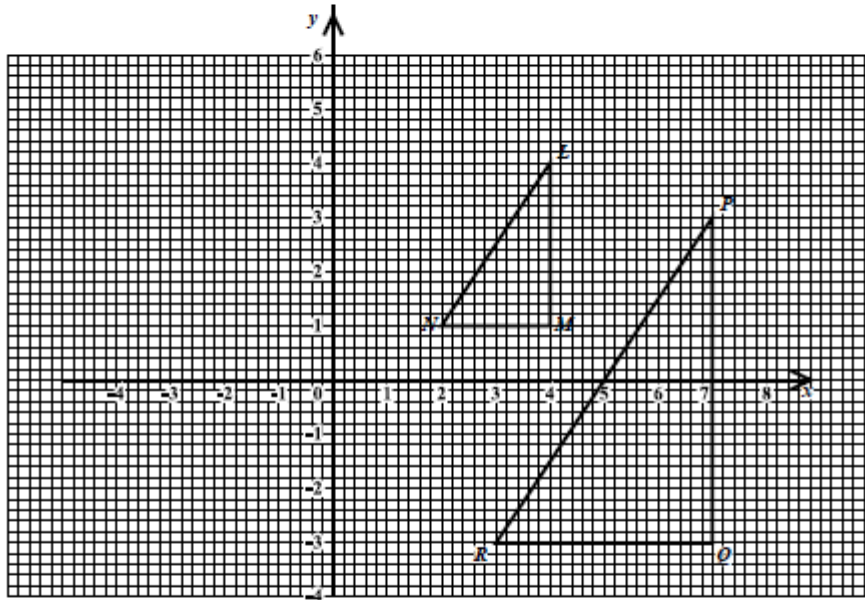

(b) Scale factor: _____ Centre: _____

(c) $\frac{\text{Area of } PQR}{\text{Area of } LMN} =$

(e) The single transformation which maps triangle LMN onto triangle ABC:

ATTACH THIS ANSWER SHEET TO YOUR ANSWER BOOKLET



CARIBBEAN EXAMINATIONS COUNCIL
 SECONDARY EDUCATION CERTIFICATE
 EXAMINATION
 MATHEMATICS

Paper 02 – General Proficiency

Answer Sheet for Question 8

Candidate Number

.....

(2 marks)

	Figure	Area of Triangle	No. of Pins on Base	
	1	1	$2 \times 1 + 1 = 3$	
	2	4	$2 \times 2 + 1 = 5$	
	3	9	$2 \times 3 + 1 = 7$	
(i)	4	_____	_____	(2 marks)
(ii)	_____	100	_____	(2 marks)
(iii)	20	_____	_____	(2 marks)
(iv)	n	_____	_____	(2 marks)

ATTACH THIS ANSWER SHEET TO YOUR ANSWER BOOKLET

FORM TP 2012092



TEST CODE 01234020

MAY/JUNE 2012

CARIBBEAN EXAMINATIONS COUNCIL
SECONDARY EDUCATION CERTIFICATE
EXAMINATION
MATHEMATICS

Paper 02 – General Proficiency

Answer Sheet for Question 9 (b)

Candidate Number

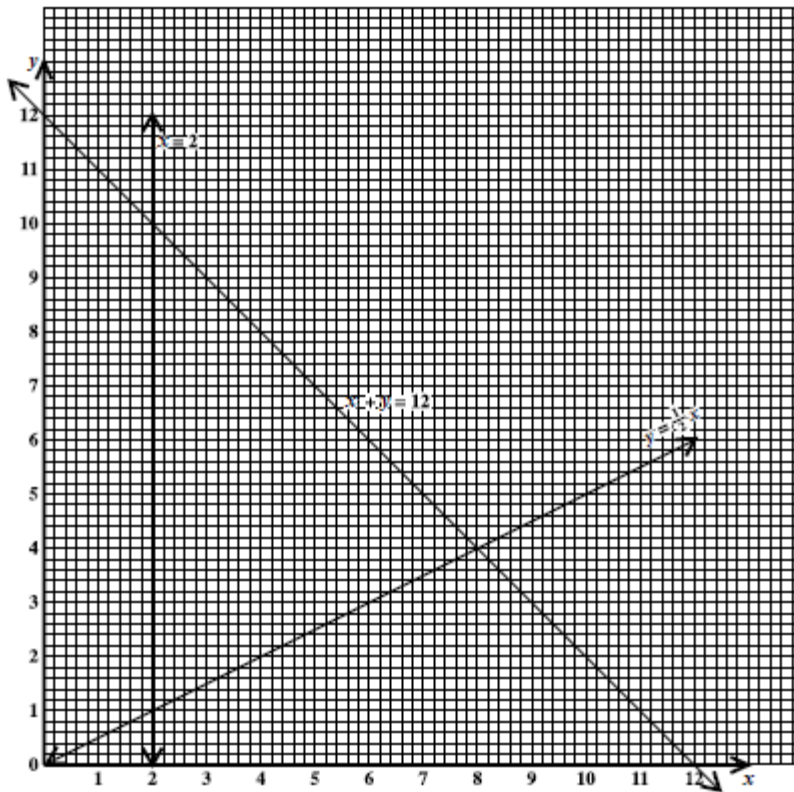

ATTACH THIS ANSWER SHEET TO YOUR ANSWER BOOKLET

FORM TP 2013017



TEST CODE **01234020**

JANUARY 2013

CARIBBEAN EXAMINATIONS COUNCIL

CARIBBEAN SECONDARY EDUCATION CERTIFICATE®
EXAMINATION

MATHEMATICS

Paper 02 – General Proficiency

2 hours 40 minutes

04 JANUARY 2013 (a.m.)

READ THE FOLLOWING INSTRUCTIONS CAREFULLY.

1. This paper consists of TWO sections.
2. There are EIGHT questions in Section I and THREE questions in Section II.
3. Answer ALL questions in Section I, and any TWO questions from Section II.
4. Write your answers in the booklet provided.
5. All working must be clearly shown.
6. A list of formulae is provided on page 2 of this booklet.

Required Examination Materials

Electronic calculator
Geometry set
Graph paper (provided)

DO NOT TURN THIS PAGE UNTIL YOU ARE TOLD TO DO SO.

Copyright © 2010 Caribbean Examinations Council
All rights reserved.

01234020/JANUARY/F 2013

LIST OF FORMULAE

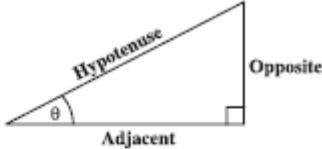
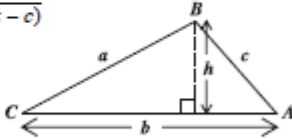
Volume of a prism	$V = Ah$ where A is the area of a cross-section and h is the perpendicular length.
Volume of cylinder	$V = \pi r^2 h$ where r is the radius of the base and h is the perpendicular height.
Volume of a right pyramid	$V = \frac{1}{3} Ah$ where A is the area of the base and h is the perpendicular height.
Circumference	$C = 2\pi r$ where r is the radius of the circle.
Arc length	$S = \frac{\theta}{360} \times 2\pi r$ where θ is the angle subtended by the arc, measured in degrees.
Area of a circle	$A = \pi r^2$ where r is the radius of the circle.
Area of a sector	$A = \frac{\theta}{360} \times \pi r^2$ where θ is the angle of the sector, measured in degrees.
Area of trapezium	$A = \frac{1}{2} (a + b) h$ where a and b are the lengths of the parallel sides and h is the perpendicular distance between the parallel sides.
Roots of quadratic equations	If $ax^2 + bx + c = 0$, then $x = \frac{-b \pm \sqrt{b^2 - 4ac}}{2a}$.
Trigonometric ratios	$\sin \theta = \frac{\text{opposite side}}{\text{hypotenuse}}$ $\cos \theta = \frac{\text{adjacent side}}{\text{hypotenuse}}$ $\tan \theta = \frac{\text{opposite side}}{\text{adjacent side}}$
	
Area of triangle	Area of $\Delta = \frac{1}{2} bh$ where b is the length of the base and h is the perpendicular height. Area of $\Delta ABC = \frac{1}{2} ab \sin C$ Area of $\Delta ABC = \sqrt{s(s-a)(s-b)(s-c)}$ where $s = \frac{a+b+c}{2}$
Sine rule	$\frac{a}{\sin A} = \frac{b}{\sin B} = \frac{c}{\sin C}$ 
Cosine rule	$a^2 = b^2 + c^2 - 2bc \cos A$

SECTION I

Answer ALL questions.

All working must be clearly shown.

1. (a) Using a calculator or otherwise, calculate the exact value of

$$(2.67 \times 4.1) - 1.3^2$$

(3 marks)

- (b) Mr Harry who lives in St Kitts is planning to travel to Barbados. A travel club offers the rates shown below.

Petty's Travel Club	
Holiday in Barbados	
Return Air Fare	US \$356.00
Hotel Accommodation	US \$97.00 per night

- (i) Calculate the TOTAL cost of airfare and hotel accommodation for 3 nights using the rates offered by Petty's Travel Club. (3 marks)
- (ii) Another travel club advertises the following package deal.

Angie's Travel Club	
Holiday in Barbados	
3 Nights Hotel Accommodation plus Return Air Fare	
EC \$1610.00	

Calculate, in US dollars, the cost of the trip for 3 nights as advertised by Angie's travel club.

$$\text{US } \$1.00 = \text{EC } \$2.70$$

(2 marks)

- (iii) State, giving a reason for your answer, which travel club (Petty's or Angie's) has the better offer. (1 mark)
- (iv) The EC \$1610.00 charged by Angie's Travel Club includes a sales tax of 15%. Calculate the cost of the trip for three nights BEFORE the sales tax was added. (2 marks)

Total 11 marks

GO ON TO THE NEXT PAGE

2. (a) Solve for p

$$2(p + 5) - 7 = 4p. \quad (2 \text{ marks})$$

- (b) Factorize completely

(i) $25m^2 - 1$ (2 marks)

(ii) $2n^2 - 3n - 20$ (2 marks)

- (c) A candy store packages lollipops and toffees in bags for sale.



x grams



y grams

5 lollipops and 12 toffees have a mass of 61 grams.
10 lollipops and 13 toffees have a mass of 89 grams.

- (i) If the mass of one lollipop is x grams and the mass of one toffee is y grams, write two equations in x and y to represent the above information. (2 marks)
- (ii) Calculate the mass of
- a) ONE lollipop
- b) ONE toffee (4 marks)

Total 12 marks

3. (a) There are 50 students in a class. Students in the class were given awards for Mathematics or Science.

36 students received awards in either Mathematics or Science.
 6 students received awards in BOTH Mathematics and Science.
 $2x$ students received awards for Mathematics only.
 x students received awards for Science only.

In the Venn Diagram below:

U = {all the students in the class}
 M = {students who received awards for Mathematics}
 S = {students who received awards for Science}

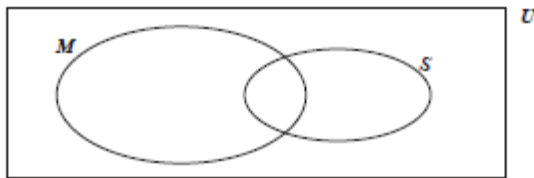

- (i) Copy and complete the Venn Diagram to represent the information about the awards given, showing the number of students in EACH subset. (4 marks)
- (ii) Calculate the value of x . (2 marks)
- (b) In the diagram below, not drawn to scale, ABC is an isosceles triangle with $AB = AC$ and angle $ABC = 54^\circ$. DE is parallel to BC .

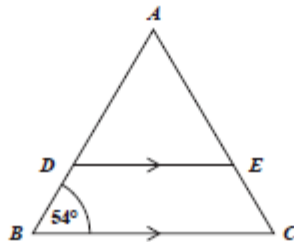

- (i) Calculate, giving a reason for your answer, the measure of:
- a) $\angle BAC$
- b) $\angle AED$ (4 marks)
- (ii) Explain why triangles ABC and ADE are similar but not congruent. (2 marks)

Total 12 marks

GO ON TO THE NEXT PAGE

4. (a) Make r the subject of EACH of the following formulae:

(i) $r - h = rh$ (2 marks)

(ii) $V = \pi r^2 h$ (2 marks)

- (b) The functions f and g are defined as follows:

$$f(x) = 2x + 5$$

$$g(x) = \frac{x-3}{2}$$

Evaluate:

(i) $f^{-1}(19)$ (2 marks)

(ii) $gf(3)$ (2 marks)

- (c) A line segment GH has equation $3x + 2y = 15$.

(i) Determine the gradient of GH . (1 mark)

(ii) Another line segment, JK , is perpendicular to GH and passes through the point $(4, 1)$. Determine the equation of the line JK . (3 marks)

Total 12 marks

5. An answer sheet is provided for this question.

- (a) The diagram below is a scale drawing showing the line RT and the north direction on a playground.

It is drawn to a scale of 1 centimetre : 30 metres.

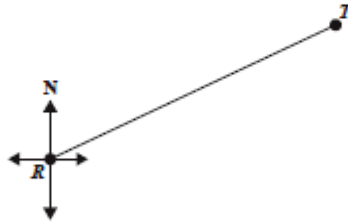

Using the answer sheet provided,

- (i) measure and state, in centimetres, the length of RT as drawn on the diagram. (1 mark)
 - (ii) measure and state, in degrees, the size of the angle that shows the bearing of T from R . (2 marks)
 - (iii) calculate the actual distance, in metres, on the playground that RT represents. (2 marks)
- (b) A point M on the playground is located 300 metres from R on a bearing of 120° .

On the same answer sheet,

- (i) calculate, in centimetres, the length of RM that should be used on the scale drawing. (2 marks)
- (ii) using a ruler and a pair of compasses, draw the line RM on the scale drawing. (4 marks)
- (iii) mark and name the angle in the scale drawing that measures 120° . (1 mark)

Total 12 marks

GO ON TO THE NEXT PAGE

6. The diagram below, not drawn to scale, shows a hollow cylinder with height 8 cm and diameter 12 cm.

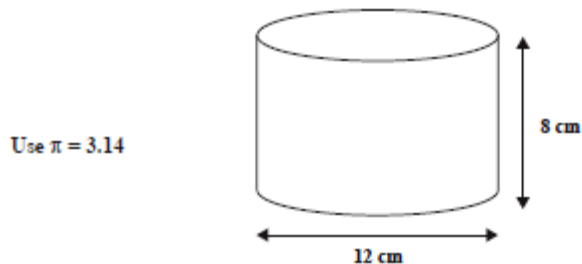

- (a) Calculate for the cylinder:
- The radius (1 mark)
 - The circumference of the cross section (2 marks)
- (b) The rectangle shown below, not drawn to scale, represents the net of the curved surface of the cylinder shown above.



- State the values of a and b . (2 marks)
 - Hence, calculate the area of the curved surface of the cylinder. (2 marks)
- (c) If 0.5 litres of water is poured into the cylinder, calculate, correct to one decimal place, the height of water in the cylinder. (4 marks)

Total 11 marks

7. The scores obtained by 100 children in a competition are summarized in the table below.

Score	Class mid-point (x)	Frequency (f)	$f \times x$
0–9	4.5	8	36
10–19	14.5	13	188.5
20–29		25	
30–39		22	
40–49		20	
50–59		12	
Total		100	

- (a) (i) State the modal class interval. **(1 mark)**
- (ii) State the class interval in which a score of 19.4 would lie. **(1 mark)**
- (b) (i) Copy and complete the table to show
- a) the class mid-points
- b) the values of " $f \times x$ " **(2 marks)**
- (ii) Calculate the mean score for the sample. **(3 marks)**
- (c) Explain why the value of the mean obtained in (b) (ii) is only an estimate of the true value. **(1 mark)**
- (d) In order to qualify for the next round of the competition a student must score AT LEAST 40 points.
- What is the probability that a student selected at random qualifies for the next round? **(2 marks)**

Total 10 marks

GO ON TO THE NEXT PAGE

8. The first three diagrams in a sequence are shown below.

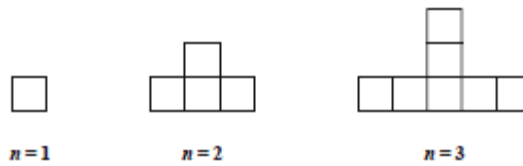

- (a) In your answer booklet, draw the FOURTH diagram in the sequence. (2 marks)
- (b) The table below shows the number of squares in EACH diagram.

	Diagram (n)	Number of Squares
	1	1
	2	4
	3	7
(i)	4	a
(ii)	10	b
(iii)	c	40

Determine the values of

- (i) a
- (ii) b
- (iii) c (5 marks)
- (c) Write down, in terms of n , the number of squares in the n^{th} diagram of the sequence. (3 marks)

Total 10 marks

GO ON TO THE NEXT PAGE

SECTION II

Answer TWO questions.

ALGEBRA AND RELATIONS, FUNCTIONS AND GRAPHS

9. (a) The table below shows corresponding values of
- x
- and
- y
- for the function

$$y = \frac{3}{x}, \quad x \neq 0$$

where y represents the velocity of a particle after x seconds.

x (sec)	0.25	0.5	1	2	3	4	5	6
y (m/s)	12		3	1.5		0.75		0.5

- (i) Copy and complete the table for the function. (2 marks)
- (ii) Using a scale of 2 cm to represent 1 unit on the x axis and 1 cm to represent 1 unit on the y axis, plot the points from your table, drawing a smooth curve through all points. (5 marks)
- (b) (i) Write $f(x) = 3x^2 - 5x + 1$ in the form $a(x - h)^2 + k$ where a , h and k are constants to be determined. (2 marks)
- (ii) Hence, or otherwise, determine the minimum value of $f(x)$ and the value of x for which $f(x)$ is a minimum. (2 marks)
- (iii) Solve the equation $3x^2 - 5x + 1 = 0$ expressing your answer correct to two decimal places. (4 marks)

Total 15 marks

GO ON TO THE NEXT PAGE

GEOMETRY AND TRIGONOMETRY

10. (a) The diagram below, not drawn to scale, shows a circle, centre O . RQ is a diameter and PM and PN are tangents to the circle. Angle $MPN = 54^\circ$ and angle $RQM = 20^\circ$.

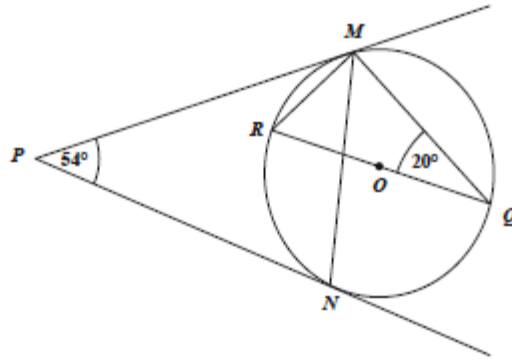

Calculate, giving reasons for your answer, the measure of:

- (i) $\angle MRQ$ (2 marks)
 (ii) $\angle PMR$ (2 marks)
 (iii) $\angle PMN$ (3 marks)
- (b) (i) The diagram below, not drawn to scale, shows the position of three points A , B and C on a horizontal plane.

$AB = 174$ metres, $BC = 65$ metres and $AC = 226$ metres

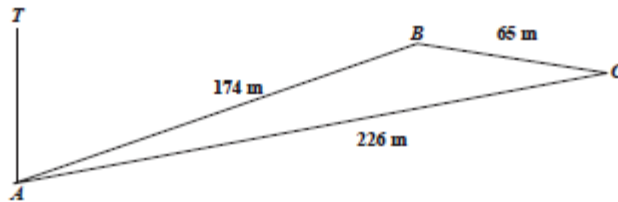

Calculate

- a) the measure of angle ABC (2 marks)
 b) the area of triangle ABC . (2 marks)

GO ON TO THE NEXT PAGE

- (ii) The line TA represents a vertical lighthouse. The angle of elevation of T from B is 23° .
- a) In your answer booklet, draw the triangle TAB showing the angle of elevation. (2 marks)
- b) Calculate the height, TA , of the lighthouse. (2 marks)

Total 15 marks

VECTORS AND MATRICES

11. (a) The diagram below, not drawn to scale, shows a parallelogram $OKLM$ where O is the origin. The point S is on KM such that $MS = 2SK$. $\vec{OK} = v$ and $\vec{OM} = u$.

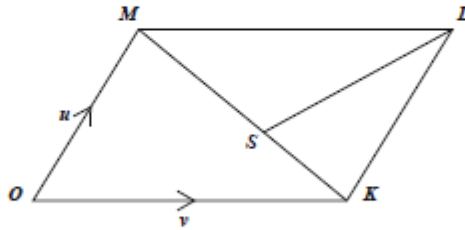

Express EACH of the following in terms of u and v :

- (i) \vec{MK} (1 mark)
- (ii) \vec{SL} (2 marks)
- (iii) \vec{OS} (2 marks)
- (b) The matrix $J = \begin{pmatrix} 0 & -1 \\ 1 & 0 \end{pmatrix}$ represents a single transformation.
- The image of the point P under transformation J is $(5, 4)$.
- Determine the coordinates of P . (3 marks)
- (c) (i) Write down a matrix, H , of size 2×2 which represents an enlargement of scale factor 3 about the origin. (1 mark)
- (ii) Determine the coordinates of the point $(5, -7)$ under the combined transformation, H followed by J . (2 marks)

GO ON TO THE NEXT PAGE

- (d) A superstore sells 3 models of cell phones. Model A costs \$40 each, model B costs \$55 each and model C costs \$120 each.

The weekly sales for 2 weeks in June were:

Week 1	Week 2
2 model A	no model A
5 model B	6 model B
3 model C	10 model C

- (i) Write down a matrix of size 3×2 which represents the sales for the two weeks. (1 mark)
- (ii) Write down a matrix of size 1×3 which represents the cost of the different models of cell phones. (1 mark)
- (iii) Write down the multiplication of the two matrices which represents the superstore's takings from the sale of cell phones for each of the two weeks. (2 marks)

Total 15 marks

END OF TEST

IF YOU FINISH BEFORE TIME IS CALLED, CHECK YOUR WORK ON THIS TEST.

FORM TP 2013017



TEST CODE 01234020

JANUARY 2013

CARIBBEAN EXAMINATIONS COUNCIL

CARIBBEAN SECONDARY EDUCATION CERTIFICATE®
EXAMINATION

MATHEMATICS

Paper 02 – General Proficiency

Answer Sheet for Question 5.

Candidate Number

(a)

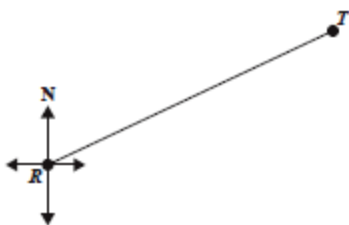

Scale: 1 cm represents 30 m

- (i) $RT =$ _____ centimetres
- (ii) Angle = _____ degrees
- (iii) Actual distance of $RT =$ _____ metres

- (b) (i) $RM =$ _____ centimetres

ATTACH THIS ANSWER SHEET TO YOUR ANSWER BOOKLET

01234020/JANUARY/F 2013

FORM TP 2013092



TEST CODE **01234020**

MAY/JUNE 2013

CARIBBEAN EXAMINATIONS COUNCIL
CARIBBEAN SECONDARY EDUCATION CERTIFICATE®
EXAMINATION

MATHEMATICS

Paper 02 – General Proficiency

2 hours 40 minutes

22 MAY 2013 (a.m.)

READ THE FOLLOWING INSTRUCTIONS CAREFULLY.

1. This paper consists of **TWO** sections.
2. There are **EIGHT** questions in Section I and **THREE** questions in Section II.
3. Answer **ALL** questions in Section I, and any **TWO** questions from Section II.
4. Write your answers in the booklet provided.
5. All working must be clearly shown.
6. A list of formulae is provided on page 2 of this booklet.

Required Examination Materials

Electronic calculator
Geometry set
Graph paper (provided)

DO NOT TURN THIS PAGE UNTIL YOU ARE TOLD TO DO SO.

Copyright © 2011 Caribbean Examinations Council
All rights reserved.

01234020/F 2013

LIST OF FORMULAE

Volume of a prism $V = Ah$ where A is the area of a cross-section and h is the perpendicular length.

Volume of cylinder $V = \pi r^2 h$ where r is the radius of the base and h is the perpendicular height.

Volume of a right pyramid $V = \frac{1}{3}Ah$ where A is the area of the base and h is the perpendicular height.

Circumference $C = 2\pi r$ where r is the radius of the circle.

Arc length $S = \frac{\theta}{360} \times 2\pi r$ where θ is the angle subtended by the arc, measured in degrees.

Area of a circle $A = \pi r^2$ where r is the radius of the circle.

Area of a sector $A = \frac{\theta}{360} \times \pi r^2$ where θ is the angle of the sector, measured in degrees.

Area of trapezium $A = \frac{1}{2}(a + b)h$ where a and b are the lengths of the parallel sides and h is the perpendicular distance between the parallel sides.

Roots of quadratic equations If $ax^2 + bx + c = 0$,
then $x = \frac{-b \pm \sqrt{b^2 - 4ac}}{2a}$

Trigonometric ratios $\sin \theta = \frac{\text{opposite side}}{\text{hypotenuse}}$

$$\cos \theta = \frac{\text{adjacent side}}{\text{hypotenuse}}$$

$$\tan \theta = \frac{\text{opposite side}}{\text{adjacent side}}$$

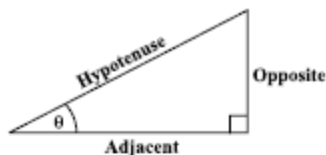

Area of triangle Area of $\Delta = \frac{1}{2}bh$ where b is the length of the base and h is the perpendicular height.

$$\text{Area of } \Delta ABC = \frac{1}{2}ab \sin C$$

$$\text{Area of } \Delta ABC = \sqrt{s(s-a)(s-b)(s-c)}$$

$$\text{where } s = \frac{a + b + c}{2}$$

Sine rule

$$\frac{a}{\sin A} = \frac{b}{\sin B} = \frac{c}{\sin C}$$

Cosine rule

$$a^2 = b^2 + c^2 - 2bc \cos A$$

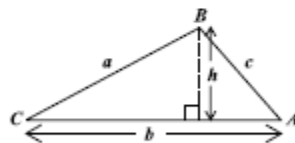

GO ON TO THE NEXT PAGE

SECTION I

Answer ALL the questions in this section.

All working must be clearly shown.

1. (a) Using a calculator, or otherwise, calculate the EXACT value of

$$(i) \frac{1\frac{4}{5} - \frac{1}{3}}{2\frac{2}{5}} \quad (2 \text{ marks})$$

$$(ii) \sqrt{1.5625} + (0.32)^2 \quad (2 \text{ marks})$$

- (b) Smiley Orange Juice is sold in cartons of two different sizes at the prices shown in the table below.

Carton Size	Cost
350 ml	\$4.20
450 ml	\$5.13

Which size carton of orange juice is the BETTER buy? Justify your answer.

(3 marks)

- (c) Faye borrowed \$9 600 at 8% per annum compound interest.

$$(i) \text{ Calculate the interest on the loan for the first year.} \quad (1 \text{ mark})$$

At the end of the first year, she repaid \$4 368.

$$(ii) \text{ How much did she still owe at the beginning of the second year?} \quad (2 \text{ marks})$$

$$(iii) \text{ Calculate the interest on the remaining balance for the second year.} \quad (1 \text{ mark})$$

Total 11 marks

2. (a) Factorize completely:
- (i) $2x^3 - 8x$ (2 marks)
 - (ii) $3x^2 - 5x - 2$ (2 marks)
- (b) (i) Make C the subject of the formula $F = \frac{9}{5}C + 32$. (2 marks)
- (ii) Given that $F = 113$, calculate the value of C . (1 mark)
- (c) 500 tickets were sold for a concert. Of these x tickets were sold at \$6 each, and the remainder at \$10 each.
- (i) Write an expression, in terms of x , for
 - a) the number of tickets sold at \$10 each (1 mark)
 - b) the TOTAL amount of money collected for the sale of the 500 tickets. (1 mark)
 - (ii) The sum of \$4108 was collected for the sale of the 500 tickets.
Calculate the number of tickets sold at \$6 each. (3 marks)

Total 12 marks

3. (a) A survey of the 30 students in Form 5 showed that some students used cameras (C) or mobile phones (M) to take photographs.

20 students used mobile phones
 $4x$ students used ONLY cameras
 x students used BOTH mobile phones and cameras
 2 students did not use either cameras or phones.

- (i) Copy the Venn diagram below and complete it to show, in terms of x , the number of students in each region. (3 marks)

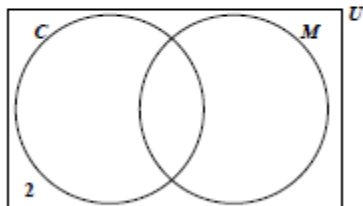

- (ii) Write an expression, in terms of x , which represents the TOTAL number of students in the survey. (1 mark)
- (iii) Determine the number of students in Form 5 who used ONLY cameras. (2 marks)
- (b) In the diagram below, not drawn to scale, AEC and ADB are straight lines.

$$\angle ABC = \angle ADE = 90^\circ.$$

$$AC = 10 \text{ m}, AB = 8 \text{ m} \text{ and } DB = 3.2 \text{ m}.$$

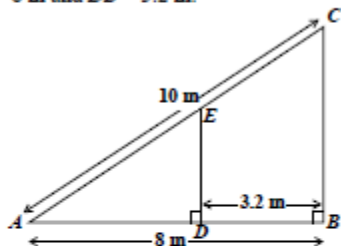

- (i) Calculate the length of BC . (2 marks)
- (ii) Explain why triangles ABC and ADE are similar. (1 mark)
- (iii) Determine the length of DE . (3 marks)

Total 12 marks

GO ON TO THE NEXT PAGE

4. (a) The diagram below shows an isosceles triangle CDE . G is the midpoint of CD .

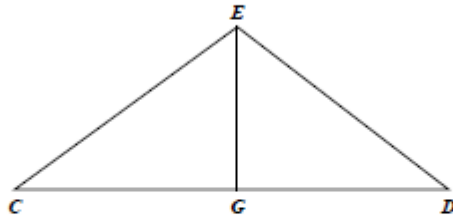

- (i) Measure and state, in centimetres, the length of DE . (1 mark)
- (ii) Measure and state, in degrees, the size of $\angle ECD$. (1 mark)
- (iii) Determine the perimeter of the triangle CDE . (2 marks)
- (iv) Calculate the area of the triangle CDE . (1 mark)
- (b) $A(-1, 4)$ and $B(3, 2)$ are the end points of a line segment AB . Determine
- (i) the gradient of AB (2 marks)
- (ii) the coordinates of the midpoint of AB (2 marks)
- (iii) the equation of the perpendicular bisector of AB . (3 marks)

Total 12 marks

5. (a) The incomplete table below shows one pair of values for A and R where A is directly proportional to the square of R .

A	36		196
R	3	5	

- (i) Express A in terms of R and a constant k . (1 mark)
- (ii) Calculate the value of the constant k . (2 marks)
- (iii) Copy and complete the table. (2 marks)
- (b) Given that $f(x) = \frac{2x+1}{3}$ and $g(x) = 4x+5$, determine the values of:
- (i) $fg(2)$ (3 marks)
- (ii) $f^{-1}(3)$ (3 marks)

Total 11 marks

6. (a) A car, travelling along a straight road at a constant speed of 54 km/h, takes 20 seconds to travel the distance between two sign posts.

Calculate

- (i) the speed of the car in m/s (2 marks)
- (ii) the distance, in metres, between the two sign posts. (2 marks)
- (b) An answer sheet is provided for this question.

The graph below shows triangle LMN and its image $L'M'N'$ after undergoing a single transformation.

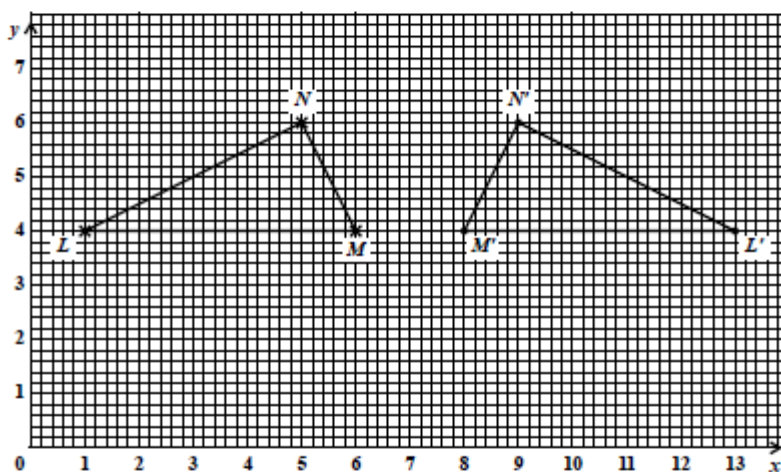

- (i) Describe fully the transformation that maps $\triangle LMN$ onto $\triangle L'M'N'$. (2 marks)
- (ii) On the answer sheet provided, draw triangle $L''M''N''$ the image of triangle LMN , after a translation by the vector $\begin{pmatrix} 0 \\ -3 \end{pmatrix}$. (2 marks)
- (iii) Name and describe a combination of TWO transformations which may be used to map $\triangle L''M''N''$ onto $\triangle L'M'N'$. (3 marks)

Total 11 marks

GO ON TO THE NEXT PAGE

7. The table below shows the amount, to the nearest dollar, spent by a group of 40 students at the school canteen during a period of one week.

Amount Spent (\$)	Number of Students	Cumulative Frequency
1 – 10	3	3
11 – 20	7	10
21 – 30	9	19
31 – 40	11	
41 – 50	8	
51 – 60	2	

- (a) Copy and complete the table to show the cumulative frequency. (2 marks)
- (b) Using a scale of 1 cm to represent \$5 on the horizontal axis and 1 cm to represent 5 students on the vertical axis, draw the cumulative frequency graph for the data. (5 marks)

(Marks will be awarded for axes appropriately labelled, points correctly plotted, and a smooth curve carefully drawn.)

- (c) Use your graph to estimate
- the median amount of money spent (2 marks)
 - the probability that a student chosen at random spent less than \$23 during the week. (2 marks)

Show on your graph, using broken lines, how these estimates were determined.

Total 11 marks

GO ON TO THE NEXT PAGE

8. An answer sheet is provided for this question.

The drawings below show the first three diagrams in a sequence.

Diagram 1

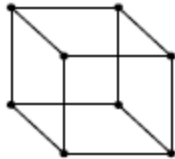

Diagram 2

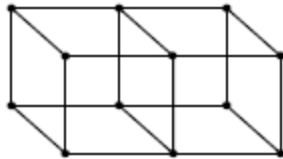
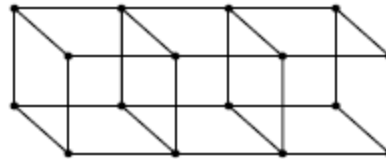
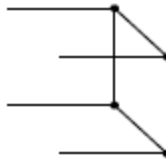

Diagram 3



Each diagram is made up of wires of equal length which are joined at the ends by balls of plasticine. Diagram 1 is made of 12 wires and 8 balls. Each new diagram in the sequence is formed by fitting the frame shown below to the right of the previous diagram.



Thus, Diagram 2 has 8 more wires and 4 more balls than Diagram 1.

On the answer sheet provided:

- (a) Draw a sketch of Diagram 4, the fourth diagram in the sequence. (2 marks)
- (b) Complete the table by inserting the missing values at the rows marked (i) and (ii).

	Name of Diagram (N)	No. of Wires (W)	No. of Balls (B)	
	1	12	8	
	2	20	12	
	3	28	16	
(i)	4	_____	_____	(2 marks)
(ii)	20	_____	_____	(4 marks)

- (c) Write the rules which may be used to find the values of W and of B where N is known.
- (i) $W =$ _____ (1 mark)
- (ii) $B =$ _____ (1 mark)

Total 10 marks

GO ON TO THE NEXT PAGE

SECTION II

Answer TWO questions in this section.

ALGEBRA AND RELATIONS, FUNCTIONS AND GRAPHS

9. (a) An answer sheet is provided for this question.

Trish wishes to buy x oranges and y mangoes which she intends to carry in her bag. Her bag has space for only 6 fruits.

- (i) Write an inequality to represent this information. (1 mark)

To get a good bargain, she must buy AT LEAST 2 mangoes.

- (ii) Write an inequality to represent this information. (1 mark)

More information about the number of oranges and mangoes associated with the good bargain is represented by

$$y \leq 2x.$$

- (iii) Write the information represented by this inequality as a sentence in your own words. (2 marks)

- (iv) On the answer sheet provided, draw the lines associated with the two inequalities obtained in (i) and (ii) above. (3 marks)

- (v) Shade on your graph the region which represents the solution set for the three inequalities. (1 mark)

- (b) (i) Write
- $3x^2 - 12x + 8$
- in the form
- $a(x + h)^2 + k$
- where
- a
- ,
- h
- and
- k
- are constants. (3 marks)

- (ii) Sketch the graph of
- $y = 3x^2 - 12x + 8$
- , showing on your sketch

- a) the intercept on the y -axis
 b) the coordinates of the minimum point. (4 marks)

Total 15 marks

MEASUREMENT, GEOMETRY AND TRIGONOMETRY

10. (a) The diagram below, not drawn to scale, shows a circle with centre O . EBC is a tangent to the circle. $\angle OBA = 40^\circ$ and $\angle OBF = 35^\circ$.

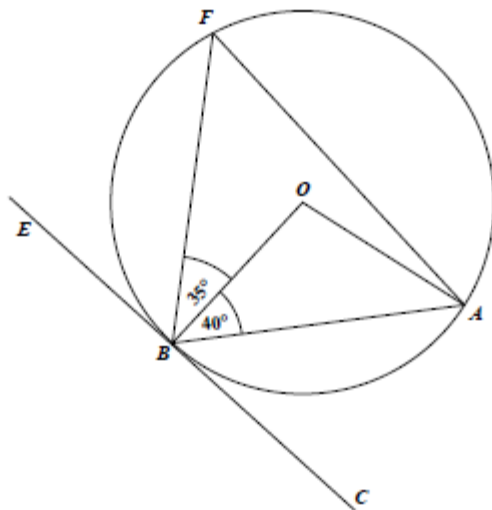

Calculate, giving reasons for your answer, the measure of

- | | | |
|-------|--------------|-----------|
| (i) | $\angle EBF$ | (1 mark) |
| (ii) | $\angle BOA$ | (2 marks) |
| (iii) | $\angle AFB$ | (2 marks) |
| (iv) | $\angle OAF$ | (2 marks) |

- (b) The diagram below, not drawn to scale, shows three points R , S and F on the horizontal ground. FT is a vertical tower of height 25 m. The angle of elevation of the top of the tower, T , from R is 27° . R is due east of F and S is due south of F . $SF = 43.3$ m.

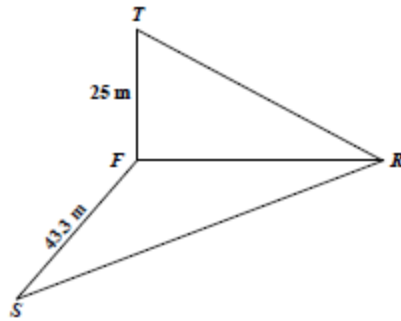

- (i) Sketch separate diagrams of the triangles RFT , TFS and SFR . Mark on EACH diagram the given measures of sides and angles. (3 marks)
- (ii) Show, by calculation, that $RF = 49.1$ m. (2 marks)
- (iii) Calculate the length of SR correct to 1 decimal place. (1 mark)
- (iv) Calculate the angle of elevation of the top of the tower, T , from S . (2 marks)

Total 15 marks

VECTORS AND MATRICES

11. (a) In the diagram below, not drawn to scale, P and Q are the midpoints of OA and AB respectively.

$$\vec{OA} = 2\mathbf{a} \text{ and } \vec{OB} = 2\mathbf{b}.$$

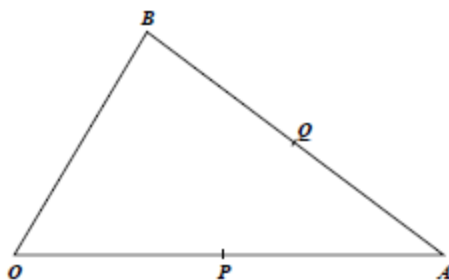

- (i) Express in terms of \mathbf{a} and \mathbf{b} the vectors
- a) \vec{AB} (2 marks)
- b) \vec{PQ} . (2 marks)
- (ii) State TWO geometrical relationships that exist between OB and PQ .
Give reasons for your answers. (2 marks)
- (b) Given that $M = \begin{pmatrix} 2 & 1 \\ 4 & 3 \end{pmatrix}$
- (i) Evaluate M^{-1} , the inverse of M . (2 marks)
- (ii) Show that $M^{-1}M = I$. (2 marks)
- (iii) Use a matrix method to solve for r , s , t and u in the equation

$$\begin{pmatrix} 2 & 1 \\ 4 & 3 \end{pmatrix} \begin{pmatrix} r & s \\ t & u \end{pmatrix} = \begin{pmatrix} 2 & 1 \\ 4 & -1 \end{pmatrix}. \quad (5 \text{ marks})$$

Total 15 marks

END OF TEST

IF YOU FINISH BEFORE TIME IS CALLED, CHECK YOUR WORK ON THIS TEST.



CARIBBEAN EXAMINATIONS COUNCIL
CARIBBEAN SECONDARY EDUCATION CERTIFICATE®
EXAMINATION
MATHEMATICS

Paper 02 – General Proficiency

Answer Sheet for Question 6 (b)

Candidate Number

- (i) _____

(ii)

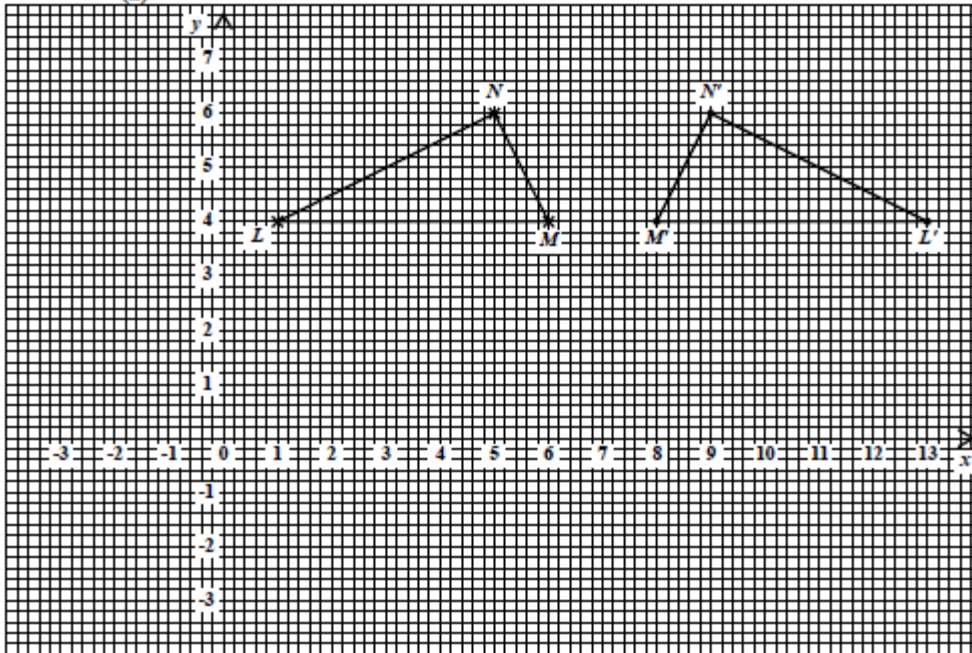

- (iii) _____

GO ON TO THE NEXT PAGE

CARIBBEAN EXAMINATIONS COUNCIL
CARIBBEAN SECONDARY EDUCATION CERTIFICATE®
EXAMINATION
MATHEMATICS

Paper 02 – General Proficiency

Answer Sheet for Question 8

Candidate Number

(a)

(b)

	Name of Diagram (<i>N</i>)	No. of Wires (<i>W</i>)	No. of Balls (<i>B</i>)
	1	12	8
	2	20	12
	3	28	16
(i)	4	_____	_____
(ii)	20	_____	_____

(c) (i) $W =$ _____(ii) $B =$ _____

ATTACH THIS ANSWER SHEET TO YOUR ANSWER BOOKLET

CARIBBEAN EXAMINATIONS COUNCIL

**CARIBBEAN SECONDARY EDUCATION CERTIFICATE®
EXAMINATION**

MATHEMATICS

Paper 02 – General Proficiency

Answer Sheet for Question 9 (a)

Candidate Number

- (i) _____
- (ii) _____
- (iii) _____
- _____
- _____

(iv)

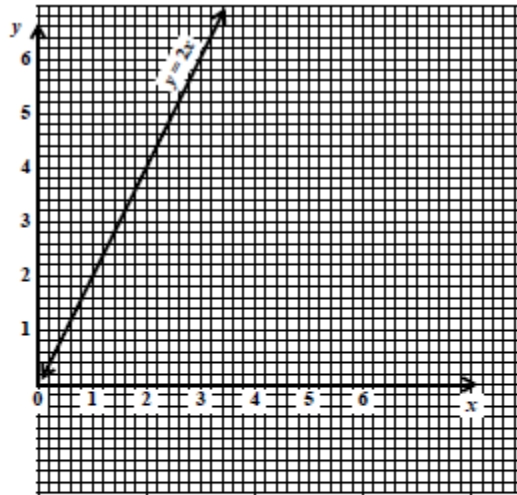

ATTACH THIS ANSWER SHEET TO YOUR ANSWER BOOKLET

FORM TP 2014017



TEST CODE **01234020**

JANUARY 2014

CARIBBEAN EXAMINATIONS COUNCIL

CARIBBEAN SECONDARY EDUCATION CERTIFICATE®
EXAMINATION

MATHEMATICS

Paper 02 – General Proficiency

2 hours 40 minutes

03 JANUARY 2014 (a.m.)

READ THE FOLLOWING INSTRUCTIONS CAREFULLY.

1. This paper consists of TWO sections.
2. There are EIGHT questions in Section I and THREE questions in Section II.
3. Answer ALL questions in Section I, and any TWO questions from Section II.
4. Write your answers in the booklet provided.
5. Begin EACH question on a separate page.
6. All working must be clearly shown.
7. A list of formulae is provided on page 3 of this booklet.

Required Examination Materials:

Electronic calculator
Geometry set
Graph paper (provided)

DO NOT TURN THIS PAGE UNTIL YOU ARE TOLD TO DO SO.

Copyright © 2011 Caribbean Examinations Council
All rights reserved.

01234020/JANUARY/F 2014

LIST OF FORMULAE

Volume of a prism	$V = Ah$ where A is the area of a cross section and h is the perpendicular length.
Volume of cylinder	$V = \pi r^2 h$ where r is the radius of the base and h is the perpendicular height.
Volume of a right pyramid	$V = \frac{1}{3} Ah$ where A is the area of the base and h is the perpendicular height.
Circumference	$C = 2\pi r$ where r is the radius of the circle.

Arc length $S = \frac{\theta}{360} \times 2\pi r$ where θ is the angle subtended by the arc, measured in degrees.

Area of a circle $A = \pi r^2$ where r is the radius of the circle.

Area of a sector $A = \frac{\theta}{360} \times \pi r^2$ where θ is the angle of the sector, measured in degrees.

Area of trapezium $A = \frac{1}{2} (a + b) h$ where a and b are the lengths of the parallel sides and h is the perpendicular distance between the parallel sides.

Roots of quadratic equations If $ax^2 + bx + c = 0$,

$$\text{then } x = \frac{-b \pm \sqrt{b^2 - 4ac}}{2a}$$

Trigonometric ratios

$$\sin \theta = \frac{\text{opposite side}}{\text{hypotenuse}}$$

$$\cos \theta = \frac{\text{adjacent side}}{\text{hypotenuse}}$$

$$\tan \theta = \frac{\text{opposite side}}{\text{adjacent side}}$$

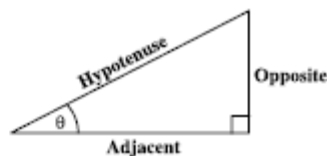

Area of triangle

Area of $\Delta = \frac{1}{2} bh$ where b is the length of the base and h is the perpendicular height.

$$\text{Area of } \Delta ABC = \frac{1}{2} ab \sin C$$

$$\text{Area of } \Delta ABC = \sqrt{s(s-a)(s-b)(s-c)}$$

$$\text{where } s = \frac{a+b+c}{2}$$

Sine rule

$$\frac{a}{\sin A} = \frac{b}{\sin B} = \frac{c}{\sin C}$$

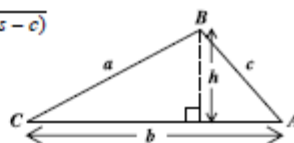

Cosine rule

$$a^2 = b^2 + c^2 - 2bc \cos A$$

GO ON TO THE NEXT PAGE

SECTION I

Answer ALL questions.

All working must be clearly shown.

1. (a) Calculate the EXACT value of

$$\left(1\frac{3}{4} - \frac{1}{8}\right) + \left(\frac{5}{6} + \frac{2}{3}\right). \quad (3 \text{ marks})$$

- (b) Using a calculator or otherwise, calculate

$$\sqrt{2.891} + \frac{1.2}{(1.31)^2}$$

giving your answer correct to 2 decimal places. (3 marks)

- (c) A jeweller paid \$6 800 for 165 bracelets bought in China. The Customs Department in his country charged him \$1 360 in duty.

- (i) Calculate the TOTAL cost of the 165 bracelets inclusive of duty. (1 mark)

- (ii) The jeweller sold the 165 bracelets at a selling price of \$68.85 EACH.

- a) Calculate the TOTAL profit he made on the sale of the 165 bracelets. (2 marks)

- b) Calculate the profit as a percentage of the cost price, giving your answer to the nearest whole number. (2 marks)

Total 11 marks

2. (a) (i) Solve for
- x
- , where
- x
- is a real number

$$2(x - 6) + 3x \leq 8. \quad (3 \text{ marks})$$

- (ii) Using a number line, show your solution to Part (a) (i). (1 mark)

- (b) Factorize completely:

- (i)
- $3x - 6y + ax - 2ay$
- (2 marks)

- (ii)
- $p^2 - 1$
- (1 mark)

GO ON TO THE NEXT PAGE

- (c) Expand and simplify

$$(2k - 3)(k - 2).$$

(2 marks)

- (d) The lines whose equations are

$$3x + y = 2 \text{ and } 4x - 2y = 6 \text{ intersect at } (x, y).$$

Show that the point of intersection is $(1, -1)$.

(3 marks)

Total 12 marks

3. (a) In a class of 32 students, ALL the students study Spanish (
- S
-) and 20 of the students study French (
- F
-).

(i) Represent this information on a Venn diagram. (2 marks)

(ii) Calculate the number of students who study Spanish (S) but NOT French (F). (1 mark)(iii) Write, using set notation, the relationship between F and S . (1 mark)

- (b) The diagram below is an accurate plan of the floor of a room. All the corners are right angles. All measures shown on the diagram are recorded to the nearest metre.

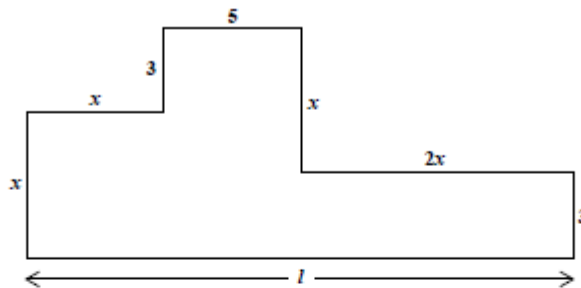
(i) State, in terms of x , the length l of the floor. (1 mark)

(ii) The perimeter of the floor is 56 metres.

a) Determine the value of x . (3 marks)

b) Calculate the area of the floor. (2 marks)

Total 10 marks

4. An answer sheet is provided for this question.

The diagram below shows the graphs of three straight lines:

$$y = 2, \quad y = x \quad \text{and} \quad y = x + 2.$$

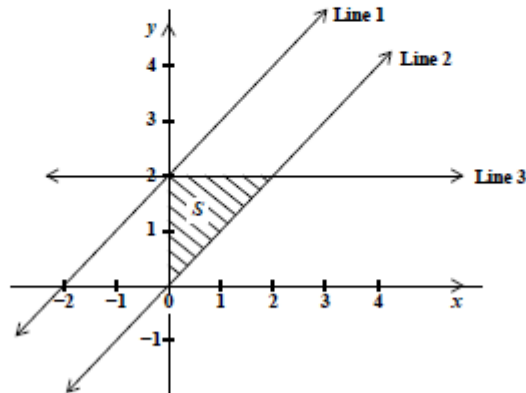

On the answer sheet

- (a) State the correct equation for EACH of the following:
- (i) Line 1 (1 mark)
 - (ii) Line 2 (1 mark)
 - (iii) Line 3 (1 mark)
- (b) Show that the gradient of Line 2 is 1. (1 mark)
- (c) Shade the region which is described as $y \geq x + 2$. (2 marks)
- (d) Write THREE inequalities that define the shaded region, S , shown in the diagram. (3 marks)
- (e) Write the equation of the straight line which is perpendicular to Line 1 and passes through the origin. (2 marks)

Total 11 marks

5. (a) (i) Using a ruler, a pencil and a pair of compasses, construct triangle ABC with
 $BC = 10$ cm $AB = 6$ cm and $AC = 8$ cm. (3 marks)
- (ii) Measure and state the size of angle ABC . (1 mark)
- (iii) Complete the diagram to show a quadrilateral, $CABD$, such that $CD = CA$ and $BD = BA$. (2 marks)
- (b) The diagram below, not drawn to scale, shows a block of metal in the shape of a prism. The cross section of the block is a trapezium, $PQRS$, with parallel sides QR and PS , and PQ , the perpendicular distance between the sides.

$$PQ = 15 \text{ cm} \quad QR = 6 \text{ cm} \quad PS = 12 \text{ cm} \quad \text{and} \quad ST = 3 \text{ cm}$$

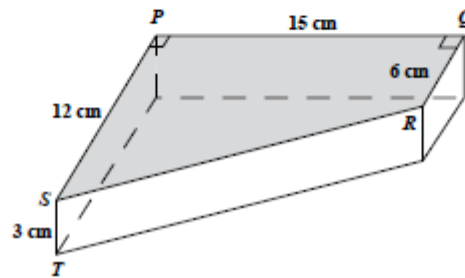

- (i) Calculate the area of the trapezium $PQRS$. (2 marks)
- (ii) Given that $ST = 3$ cm, calculate the volume of the block of metal. (1 mark)
- (iii) The block of metal has a mass of 1.5 kg. Calculate, in grams, the mass of ONE cubic centimetre of metal. (3 marks)

Total 12 marks

GO ON TO THE NEXT PAGE

6. (a) In the figure below, not drawn to scale, the lines AQB and $CRPD$ are parallel and $MQRN$ is a transversal. $PQ = PR$ and angle $QPR = 28^\circ$.

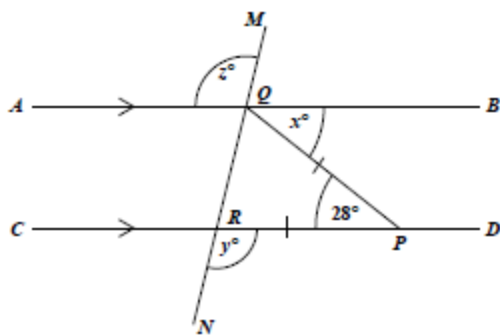

Calculate, giving reasons for your answer, the value of

- | | | |
|-------|-----|-----------|
| (i) | x | (2 marks) |
| (ii) | y | (2 marks) |
| (iii) | z | (2 marks) |

GO ON TO THE NEXT PAGE

- (b) The diagram below shows triangle JKL and its image $J'K'L'$ after a transformation.

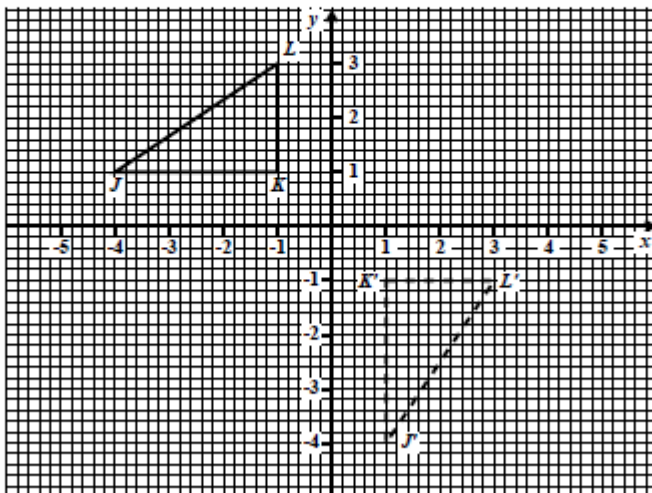

- (i) State the coordinates of the vertex, J , of triangle JKL . (1 mark)
- (ii) State the length of the side $K'L'$ of triangle $J'K'L'$. (1 mark)
- (iii) Describe FULLY a single transformation that maps triangle JKL onto triangle $J'K'L'$. (2 marks)
- (iv) State the coordinates of triangle $J''K''L''$, the image of triangle JKL , under the translation by the vector $\begin{pmatrix} 5 \\ -3 \end{pmatrix}$. (2 marks)

Total 12 marks

7. The heights of a sample of seedlings were measured to the nearest centimetre and then arranged in class intervals as shown in the table below.

Height in cm	Midpoint	Frequency
3–7	5	0
8–12	10	3
13–17	15	12
18–22		16
23–27		22
28–32		18
33–37		14

- (a) How many seedlings were in the sample? (1 mark)
- (b) For the class interval written as “8–12” in the table above, write down
- (i) the lower class limit (1 mark)
 - (ii) the upper class boundary (1 mark)
 - (iii) the class width. (1 mark)
- (c) Copy and complete the table by inserting
- (i) the midpoints of EACH class interval (2 marks)
 - (ii) the missing values for the class interval after the interval “33–37”. (1 mark)
- (d) Using a scale of 2 cm to represent 5 cm on the horizontal axis and 2 cm to represent 5 seedlings on the vertical axis, draw a frequency polygon to represent the data as shown in your table at (c). (5 marks)

Total 12 marks

GO ON TO THE NEXT PAGE

8. An answer sheet is provided for this question.

The diagram below shows the first three figures in a sequence of figures. Each figure is made up of one or more trapezia with dots one unit apart on their parallel sides. Each trapezium can be partitioned into four congruent triangles as follows:



- (a) On the answer sheet provided, draw Figure 4, the FOURTH figure in the sequence. (2 marks)
- (b) Study the patterns in the table shown below. Complete the table by inserting the missing values in the rows numbered (i), (ii), (iii) and (iv).

	No. of Trapezia (n)	No. of Triangles	No. of Dots	
	1	4	6	
	2	8	10	
	3	12	14	
(i)	4	_____	_____	(2 marks)
(ii)	10	_____	_____	(2 marks)
(iii)	_____	64	_____	(2 marks)
(iv)	n	_____	_____	(2 marks)

Total 10 marks

GO ON TO THE NEXT PAGE

SECTION II

Answer TWO questions.

ALGEBRA AND RELATIONS, FUNCTIONS AND GRAPHS

9. (a) The functions $h(x)$ and $g(x)$ are defined as

$$h(x) = \frac{10}{x} - 3 \quad g(x) = 3x - 2.$$

- (i) Evaluate:

a) $g(4)$

(1 mark)

b) $hg(4)$

(2 marks)

- (ii) Write expressions in x for:

a) $h^{-1}(x)$

b) $g \circ g(x)$

(4 marks)

- (b) The diagram below shows a sketch of the quadratic function

$$y = x^2 + bx + c, \quad -2 \leq x \leq 6$$

where b and c are constants.

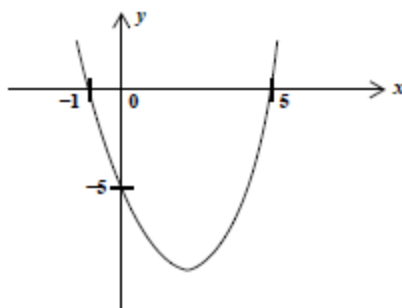

- (i) State the roots of the equation $x^2 + bx + c = 0$. (2 marks)
- (ii) For the function $y = x^2 + bx + c$
- a) determine the value of c (2 marks)
- b) show that $b = -4$. (2 marks)
- (iii) State the coordinates of the MINIMUM point on the graph of the function $y = x^2 + bx + c$. (2 marks)

Total 15 marks

GEOMETRY AND TRIGONOMETRY

10. (a) In the diagram below, not drawn to scale, O is the centre of the circle. The lines SK and AF are parallel.

$$\angle KSW = 62^\circ \quad \angle SAF = 54^\circ$$

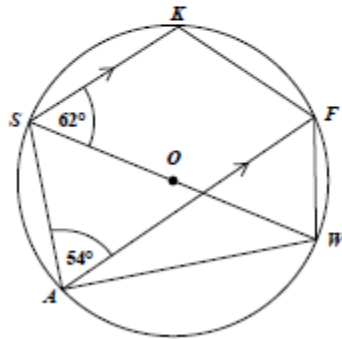

Calculate, giving reasons for your answer, the measure of:

- | | |
|--------------------|-----------|
| (i) $\angle FAW$ | (2 marks) |
| (ii) $\angle SKF$ | (2 marks) |
| (iii) $\angle ASW$ | (2 marks) |

GO ON TO THE NEXT PAGE

- (b) The diagram below, not drawn to scale, shows the positions of three points, P , Q and R on a horizontal plane.

$$PQ = 120 \text{ km} \quad PR = 150 \text{ km} \quad \angle QPR = 23^\circ$$

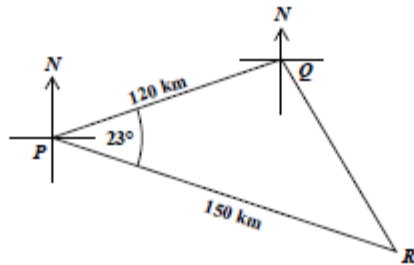

- (i) Calculate, correct to one decimal place
- the distance QR (3 marks)
 - the area of triangle PQR . (2 marks)
- (ii) The bearing of P from Q is 252° . Calculate the bearing of R from P . (4 marks)

Total 15 marks

VECTORS AND MATRICES

11. (a) The matrix, T , is such that

$$T = \begin{pmatrix} 2 & -1 \\ 1 & 3 \end{pmatrix}.$$

- (i) Determine, T^{-1} , the inverse of T . (3 marks)
- (ii) The matrix T maps the point (a, b) onto the point $(4, 9)$. Determine the values of a and b . (4 marks)

- (b) \vec{OM} and \vec{ON} are position vectors with respect to the origin, O , such that

$$\vec{OM} = \mathbf{m} \quad \text{and} \quad \vec{ON} = \mathbf{n}$$

L is a point on MN such that $ML : LN = 2 : 1$.

- (i) Draw a sketch of the triangle OMN and label the points O, M, N and L . (2 marks)
- (ii) Write in terms of \mathbf{m} and \mathbf{n} an expression for:
- a) \vec{MN}
- b) \vec{ML} (3 marks)
- (iii) If $\mathbf{m} = \begin{pmatrix} 3 \\ 6 \end{pmatrix}$ and $\mathbf{n} = \begin{pmatrix} 9 \\ 0 \end{pmatrix}$,

determine the position vector of L . (3 marks)

Total 15 marks

END OF TEST

IF YOU FINISH BEFORE TIME IS CALLED, CHECK YOUR WORK ON THIS TEST.

FORM TP 2014017



TEST CODE 01234020

JANUARY 2014

CARIBBEAN EXAMINATIONS COUNCIL

CARIBBEAN SECONDARY EDUCATION CERTIFICATE®
EXAMINATION

MATHEMATICS

Paper 02 – General Proficiency

Answer Sheet for Question 4.

Candidate Number

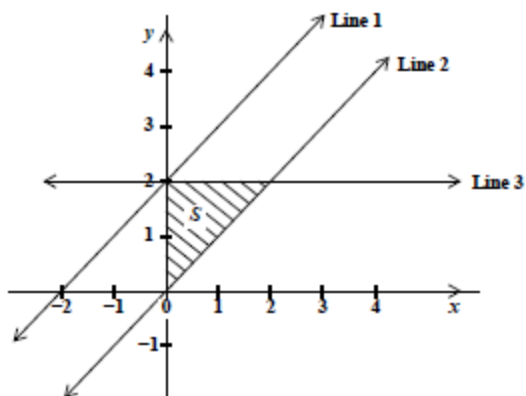

- (a) (i) Line 1: _____
(ii) Line 2: _____
(iii) Line 3: _____
- (b) _____
- (d) Inequalities that define S : _____

- (e) Equation of the straight line: _____

ATTACH THIS ANSWER SHEET TO YOUR ANSWER BOOKLET

FORM TP 2014017



TEST CODE 01234020

JANUARY 2014

CARIBBEAN EXAMINATIONS COUNCIL

CARIBBEAN SECONDARY EDUCATION CERTIFICATE®
EXAMINATION

MATHEMATICS

Paper 02 – General Proficiency

Answer Sheet for Question 8.

Candidate Number

(a)

--

(b)

	No. of Trapezia (n)	No. of Triangles	No. of Dots
	1	4	6
	2	8	10
	3	12	14
(i)	4	_____	_____
(ii)	10	_____	_____
(iii)	_____	64	_____
(iv)	n	_____	_____

ATTACH THIS ANSWER SHEET TO YOUR ANSWER BOOKLET

01234020/JANUARY/F 2014



TEST CODE **01234020**

FORM TP 2014089

MAY/JUNE 2014

**CARIBBEAN EXAMINATIONS COUNCIL
CARIBBEAN SECONDARY EDUCATION CERTIFICATE®
EXAMINATION
MATHEMATICS**

Paper 02 – General Proficiency

2 hours 40 minutes

21 MAY 2014 (a.m.)

READ THE FOLLOWING INSTRUCTIONS CAREFULLY.

1. This paper consists of TWO sections: I and II.
2. Section I has EIGHT questions and Section II has THREE questions.
3. Answer ALL questions in Section I, and any TWO questions from Section II.
4. Write your answers in the booklet provided.
5. Begin EACH question on a separate page.
6. All working must be shown clearly.
7. A list of formulae is provided on page 2 of this booklet.

Required Examination Materials

Electronic calculator
Geometry set
Graph paper (provided)

DO NOT TURN THIS PAGE UNTIL YOU ARE TOLD TO DO SO.

Copyright © 2013 Caribbean Examinations Council
All rights reserved.

01234020/F 2014

LIST OF FORMULAE

Volume of a prism	$V = Ah$ where A is the area of a cross-section and h is the perpendicular length.
Volume of cylinder	$V = \pi r^2 h$ where r is the radius of the base and h is the perpendicular height.
Volume of a right pyramid	$V = \frac{1}{3}Ah$ where A is the area of the base and h is the perpendicular height.
Circumference	$C = 2\pi r$ where r is the radius of the circle.
Arc length	$S = \frac{\theta}{360} \times 2\pi r$ where θ is the angle subtended by the arc, measured in degrees.
Area of a circle	$A = \pi r^2$ where r is the radius of the circle.
Area of a sector	$A = \frac{\theta}{360} \times \pi r^2$ where θ is the angle of the sector, measured in degrees.
Area of trapezium	$A = \frac{1}{2}(a + b)h$ where a and b are the lengths of the parallel sides and h is the perpendicular distance between the parallel sides.
Roots of quadratic equations	If $ax^2 + bx + c = 0$, then $x = \frac{-b \pm \sqrt{b^2 - 4ac}}{2a}$
Trigonometric ratios	$\sin \theta = \frac{\text{opposite side}}{\text{hypotenuse}}$ $\cos \theta = \frac{\text{adjacent side}}{\text{hypotenuse}}$ $\tan \theta = \frac{\text{opposite side}}{\text{adjacent side}}$
Area of triangle	<p>Area of $\Delta = \frac{1}{2}bh$ where b is the length of the base and h is the perpendicular height.</p> <p>Area of $\Delta ABC = \frac{1}{2}ab \sin C$</p> <p>Area of $\Delta ABC = \sqrt{s(s-a)(s-b)(s-c)}$</p> <p>where $s = \frac{a+b+c}{2}$</p>
Sine rule	$\frac{a}{\sin A} = \frac{b}{\sin B} = \frac{c}{\sin C}$
Cosine rule	$a^2 = b^2 + c^2 - 2bc \cos A$

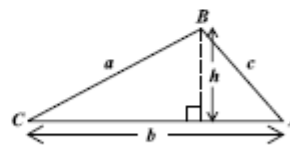
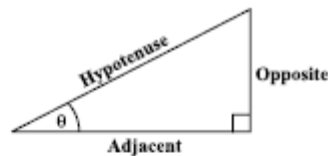

GO ON TO THE NEXT PAGE

SECTION I

Answer ALL the questions in this section.

All working must be clearly shown.

1. (a) Using a calculator, or otherwise, determine the value of:
- (i) $5.25 \div 0.015$ (1 mark)
 - (ii) $\sqrt{6.5025}$ (1 mark)
 - (iii) 3.142×2.236^2 (correct to 3 significant figures) (2 marks)
- (b) Concrete tiles are made using buckets of cement, sand and gravel mixed in the ratio 1:4:6.
- (i) How many buckets of gravel are needed for 4 buckets of cement? (2 marks)
 - (ii) If 20 buckets of sand are used, how many buckets of EACH of the following will be needed?
 - a) Cement
 - b) Gravel (3 marks)
- (c) The cash price of a laptop is \$1 299. It can be bought on hire purchase by making a deposit of \$350 and 10 monthly payments of \$120 each.
- (i) What is the TOTAL hire purchase price of the laptop? (2 marks)
 - (ii) How much is saved by buying the laptop for cash? (1 mark)

Total 12 marks

2. (a) Write as a single fraction in its **LOWEST** terms

$$\frac{x-2}{3} + \frac{x+1}{4} \quad (3 \text{ marks})$$

- (b) Write an equation in x to represent **EACH** statement below. Do **NOT** solve the equation.

(i) When 4 is added to a certain number the result is the same as halving the number and adding 10. (1 mark)

(ii) Squaring a number and subtracting 6 gives the same result as doubling the number and adding 9. (1 mark)

- (c) John drew the diagram below to show what he was thinking.

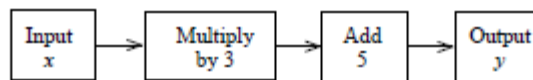

(i) Use information from the diagram to write a formula for y in terms of x . (1 mark)

(ii) If the number 4 is the input, what number would be the output? (1 mark)

(iii) If the number 8 was the output, what number was the input? (1 mark)

(iv) Reverse the formula written at (c) (i) above to write x in terms of y . (1 mark)

- (d) Solve the following simultaneous equations:

$$2x + 3y = 9$$

$$3x - y = 8$$

(3 marks)

Total 12 marks

3. (a) The universal set, U , is defined as the set of integers between 11 and 26.
 A and B are subsets of U such that:
 $A = \{\text{even numbers}\}$
 $B = \{\text{multiples of 3}\}$
- (i) How many members are in the universal set, U ? (1 mark)
- (ii) List the members of the subset A . (1 mark)
- (iii) List the members of the subset B . (1 mark)
- (iv) Draw a Venn diagram to represent the relationships among A , B and U . (3 marks)
- (b) (i) Using a ruler, a pencil and a pair of compasses, construct
- a) a triangle PQR in which $PQ = 8$ cm, $PR = 6$ cm and angle $P = 60^\circ$ (3 marks)
- b) the line segment RX which is perpendicular to PQ and meets PQ at X . (2 marks)
- [Note: Credit will be given for clearly drawn construction lines.]
- (ii) Measure and state the size of angle QRX . (1 mark)

Total 12 marks

4. The diagram below shows a map of an island drawn on a grid of 1-cm squares. The map is drawn to a scale of 1:50 000.

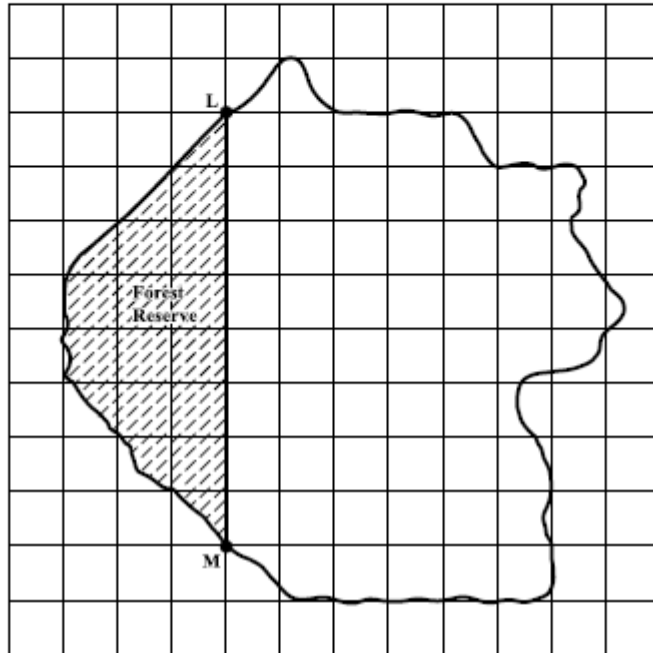

- (a) Copy and complete EACH of the following sentences:
- (i) 1 cm on the map represents _____ cm on the island. (1 mark)
 - (ii) An area of 1 cm² on the map represents an area of _____ cm² on the island. (1 mark)
 - (iii) Given that 1 km = 100 000 cm, a distance of 1 cm on the map represents a distance of _____ km on the island. (1 mark)

- (b) (i) L and M are two tracking stations. State, in centimetres, the distance LM on the map. (1 mark)
- (ii) Calculate the ACTUAL distance, in kilometres, from L to M on the island. (2 marks)
- (c) (i) The area shaded on the map is a forest reserve. By counting squares estimate, in cm^2 , the area of the forest reserve as shown on the map. (2 marks)
- (ii) Calculate, in km^2 , the ACTUAL area of the forest reserve. (2 marks)

Total 10 marks

5. An answer sheet is provided for this question.

(a) Triangle ABC has coordinates $A(1,2)$, $B(4,2)$ and $C(1,0)$.

- (i) On the answer sheet provided, draw triangle $A'B'C'$, the image of triangle ABC , under an enlargement, centre O and scale factor 2. (3 marks)
- (ii) Triangle $A''B''C''$ is the image of triangle ABC , under a transformation, M . Describe completely the transformation, M . (3 marks)

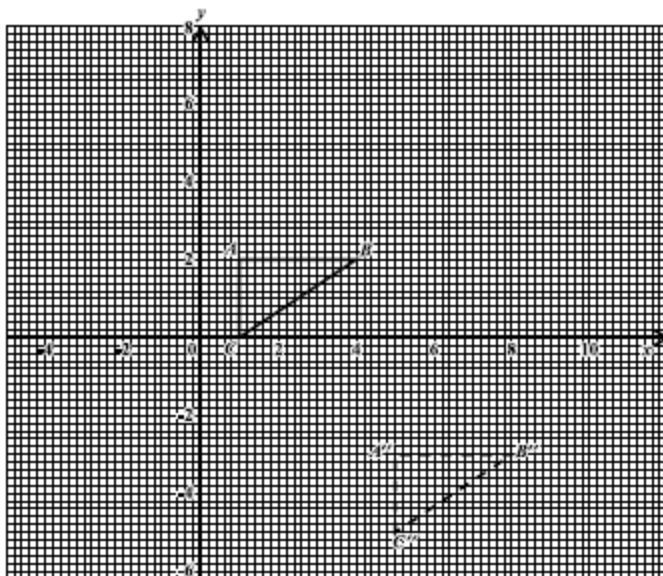

(b) The diagram below, not drawn to scale, shows the positions of two ships, P and Q , at anchor. FT is the vertical face of a cliff jutting out of the water. P and Q are 118 m apart. $FT = 80$ m and $\angle FPT = 40^\circ$.

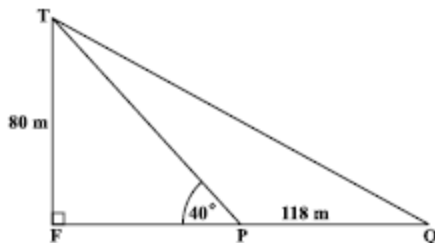

Determine

- (i) the angle of elevation of T from Q . (1 mark)
- (ii) the length of FP . (2 marks)
- (iii) the angle of elevation of T from Q . (3 marks)

Total 12 marks

GO ON TO THE NEXT PAGE

6. An answer sheet is provided for this question.

The graph of the quadratic function $y = x^2$ for $-4 \leq x \leq 4$ is shown below.

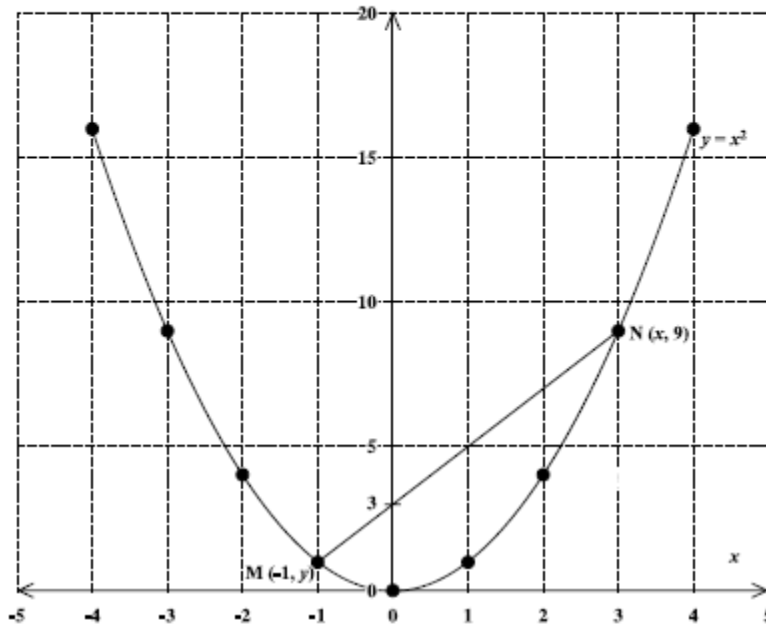

- (a) The coordinates of the points M and N are $(-1, y)$ and $(x, 9)$ respectively.
- Determine the value of
- x (1 mark)
 - y . (1 mark)
- (b) Determine
- the gradient of the line MN (1 mark)
 - the equation of the line MN (2 marks)
 - the equation of the line parallel to MN, and passing through the origin. (2 marks)
- (c) On the answer sheet provided, carefully draw the tangent line to the graph $y = x^2$ at the point $(2, 4)$. (2 marks)
- (d) Estimate the gradient of the tangent to the curve at $(2, 4)$. (2 marks)

Total 11 marks

7. A class of 30 students counted the number of books in their bags on a certain day. The number of books in EACH bag is shown below.

5 4 6 3 2 1 7 4 5 3
 6 5 4 3 7 6 2 5 4 5
 5 7 5 4 3 2 1 6 3 4

- (a) Copy and complete the frequency table for the data shown above.

Number of Books (x)	Tally	Frequency (f)	$f \times x$
1		2	2
2		3	6
3			
4			
5			
6			
7			

(4 marks)

- (b) State the modal number of books in the bags of the sample of students. (1 mark)
- (c) Using the table in (a) above, or otherwise, calculate
- (i) the TOTAL number of books (2 marks)
- (ii) the mean number of books per bag. (2 marks)
- (d) Determine the probability that a student chosen at random has LESS THAN 4 books in his/her bag. (2 marks)

Total 11 marks

8. An answer sheet is provided for this question.

A number sequence may be formed by counting the number of dots used to draw each of a set of geometric figures. The first three figures are shown below.

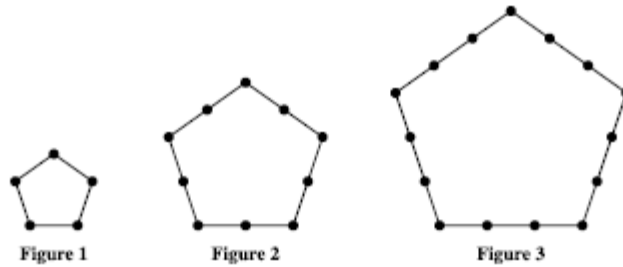

On the answer sheet provided,

- (a) Draw Figure 4, the next figure in the sequence above. (2 marks)
- (b) Complete the table below by inserting the missing information at the rows numbered (i) and (ii).

Figure (f)	Total Number of Dots	
	Formula	Number (n)
1	$5 \times 2 - 5$	5
2	$5 \times 3 - 5$	10
3	$5 \times 4 - 5$	15
4	Not Required	Not Required
(i) 5		
(ii) 6		

(4 marks)

- (c) Write an expression in f for the number (n) of dots used in drawing the f th figure. (2 marks)
- (d) Which figure in the sequence contains 145 dots? (2 marks)

Total 10 marks

SECTION II

Answer TWO questions in this section.

ALGEBRA AND RELATIONS, FUNCTIONS AND GRAPHS

9. (a) Two functions are defined as follows:

$$g(x) = 4x + 3$$

$$f(x) = \frac{2x + 7}{x + 1}$$

- (i) State the value of x for which $f(x)$ is undefined. (1 mark)
- (ii) Calculate the value of $gf(5)$. (3 marks)
- (iii) Find $f^{-1}(x)$. (3 marks)
- (b) A ball is thrown vertically upwards. Its height, h metres, above the ground after t seconds is shown in the table below.

t (s)	0	1	2	3	4	5	6
h (m)	0	50	80	90	80	50	0

- (i) Using 2 cm to represent 1 second on the x -axis and 1 cm to represent 10 metres on the y -axis, plot a graph to show the height of the ball during the first 6 seconds. (4 marks)
- (ii) Using your graph, determine
- a) the average speed of the ball during the first 2 seconds (2 marks)
- b) the speed of the ball when $t = 3$ seconds. (2 marks)

Total 15 marks

MEASUREMENT, GEOMETRY AND TRIGONOMETRY

10. (a) The diagram below, not drawn to scale, shows a circle, centre O . The line BC is a tangent to the circle at B . Angle $CBD = 42^\circ$ and angle $OBE = 20^\circ$.

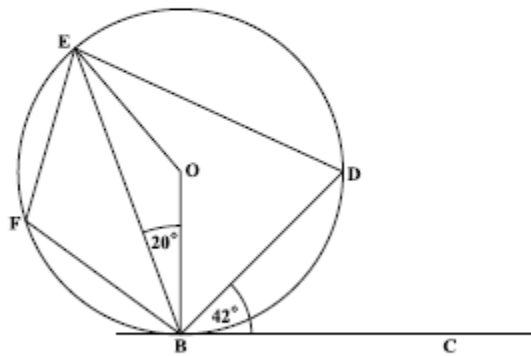

Calculate, giving a reason for EACH step of your answer, the measure of:

- | | | |
|-------|--------------|-----------|
| (i) | $\angle BOE$ | (2 marks) |
| (ii) | $\angle OED$ | (2 marks) |
| (iii) | $\angle BFE$ | (3 marks) |

- (b) The diagram below, not drawn to scale, shows the positions of three ports, P , Q and R .

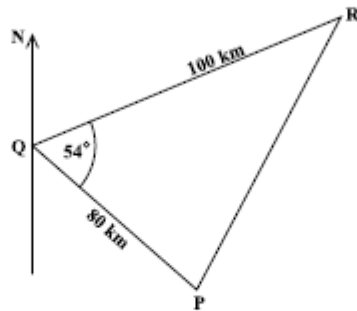

Q is 80 km from P .

R is 100 km from Q on a bearing of 066° .

$\angle PQR = 54^\circ$.

Calculate

- | | | |
|-------|--|-----------|
| (i) | the bearing of P from Q | (2 marks) |
| (ii) | the distance PR correct to 2 decimal places | (3 marks) |
| (iii) | the measure of $\angle QPR$ to the nearest degree. | (3 marks) |

Total 15 marks

VECTORS AND MATRICES

11. (a) The matrix
- M
- is defined as

$$M = \begin{pmatrix} 7 & 2 \\ p & -1 \end{pmatrix}$$

Determine the value of p for which the matrix M does NOT have an inverse.

(2 marks)

- (b) Express the equations

$$4x - 2y = 0$$

$$2x + 3y = 4$$

in the form $AX = B$, where A , X and B are matrices.

(2 marks)

- (c) In the diagram below, the coordinates of
- P
- and
- Q
- are
- $(2, 4)$
- and
- $(8, 2)$
- respectively. The line segment joining the origin
- $(0, 0)$
- to the point
- P
- may be written as
- \vec{OP}
- .

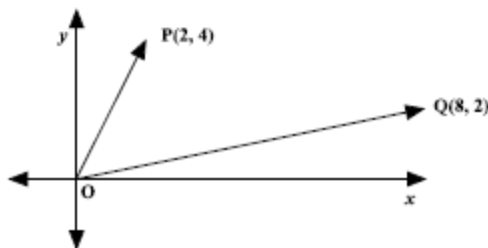

- (i) What term is used to describe \vec{OP} ? (2 marks)
- (ii) Write EACH of the following in the form: $\begin{pmatrix} a \\ b \end{pmatrix}$
- a) \vec{OP} (1 mark)
- b) \vec{OQ} (1 mark)
- c) \vec{PQ} (2 marks)
- (iii) Given that $\vec{OP} = \vec{RQ}$, determine the coordinates of the point, R . (3 marks)
- (iv) State the type of quadrilateral formed by $PQRO$. Justify your answer. (2 marks)

Total 15 marks

END OF TEST

IF YOU FINISH BEFORE TIME IS CALLED, CHECK YOUR WORK ON THIS TEST.



CARIBBEAN EXAMINATIONS COUNCIL
CARIBBEAN SECONDARY EDUCATION CERTIFICATE®
EXAMINATION
MATHEMATICS

Paper 02 – General Proficiency

Answer Sheet for Question 5 (a)

Candidate Number

(i)

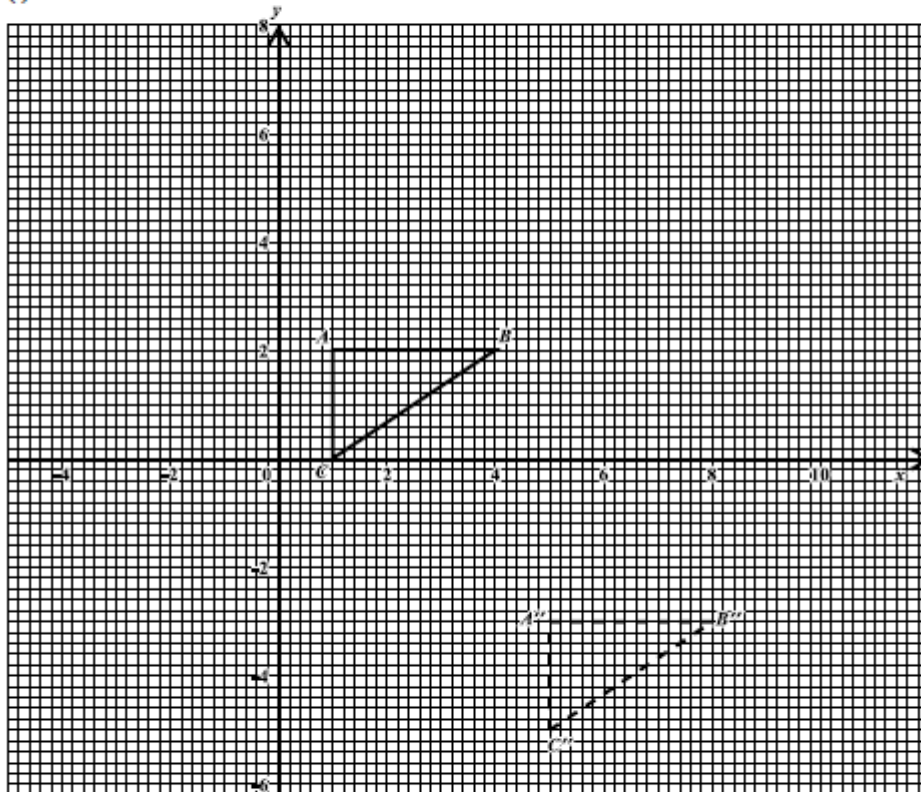

(ii) The transformation, M , that maps triangle ABC onto triangle $A'B'C'$ is

ATTACH THIS ANSWER SHEET TO YOUR ANSWER BOOKLET



CARIBBEAN EXAMINATIONS COUNCIL
 CARIBBEAN SECONDARY EDUCATION CERTIFICATE®
 EXAMINATION
 MATHEMATICS

Paper 02 – General Proficiency

Answer Sheet for Question 6 (c) and (d)

Candidate Number

(c)

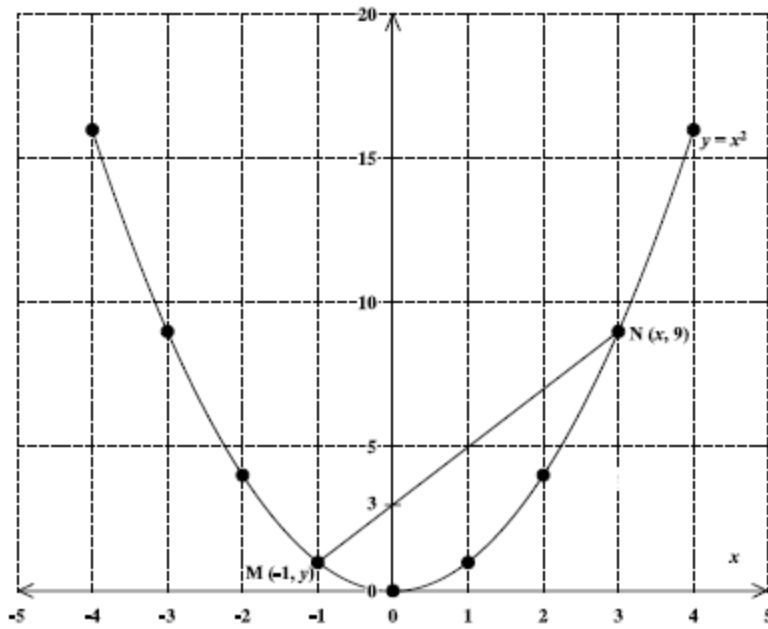

(d) The gradient of the tangent to the graph at (2, 4) is _____

ATTACH THIS ANSWER SHEET TO YOUR ANSWER BOOKLET

TEST CODE **01234020****FORM TP 2014089**

MAY/JUNE 2014

**CARIBBEAN EXAMINATIONS COUNCIL
CARIBBEAN SECONDARY EDUCATION CERTIFICATE®
EXAMINATION
MATHEMATICS**

Paper 02 – General Proficiency

Answer Sheet for Question 8

Candidate Number

(a)

Figure 4

(b)

Figure (<i>f</i>)	Total Number of Dots	
	Formula	Number (<i>n</i>)
1	$5 \times 2 - 5$	5
2	$5 \times 3 - 5$	10
3	$5 \times 4 - 5$	15
4	Not Required	Not Required
(i) 5		
(ii) 6		

(c) Expression in n : _____

(d) Which figure in the sequence contains 145 dots? _____

ATTACH THIS ANSWER SHEET TO YOUR ANSWER BOOKLET

01234020/F 2014

FORM TP 2015017



TEST CODE **01234020**

JANUARY 2015

CARIBBEAN EXAMINATIONS COUNCIL
CARIBBEAN SECONDARY EDUCATION CERTIFICATE®
EXAMINATION

MATHEMATICS

Paper 02 – General Proficiency

2 hours 40 minutes

READ THE FOLLOWING INSTRUCTIONS CAREFULLY.

1. This paper consists of TWO sections: I and II.
2. Section I has EIGHT questions and Section II has THREE questions.
3. Answer ALL questions in Section I, and any TWO questions from Section II.
4. Write your answers in the booklet provided.
5. Do NOT write in the margins.
6. All working MUST be shown clearly.
7. A list of formulae is provided on page 2 of this booklet.
8. If you need to rewrite any answer and there is not enough space to do so on the original page, you must use the extra page(s) provided at the back of this booklet. Remember to draw a line through your original answer.
9. If you use the extra page(s) you MUST write the question number clearly in the box provided at the top of the extra page(s) and, where relevant, include the question part beside the answer.

Required Examination Materials:

Electronic calculator
Geometry set

DO NOT TURN THIS PAGE UNTIL YOU ARE TOLD TO DO SO.

Copyright © 2013 Caribbean Examinations Council
All rights reserved.

01234020/JANUARY/F 2015



0123402003

LIST OF FORMULAE

Volume of a prism $V = Ah$ where A is the area of a cross section and h is the perpendicular length.

Volume of cylinder $V = \pi r^2 h$ where r is the radius of the base and h is the perpendicular height.

Volume of a right pyramid $V = \frac{1}{3} Ah$ where A is the area of the base and h is the perpendicular height.

Circumference $C = 2\pi r$ where r is the radius of the circle.

Arc length $S = \frac{\theta}{360} \times 2\pi r$ where θ is the angle subtended by the arc, measured in degrees.

Area of a circle $A = \pi r^2$ where r is the radius of the circle.

Area of a sector $A = \frac{\theta}{360} \times \pi r^2$ where θ is the angle of the sector, measured in degrees.

Area of trapezium $A = \frac{1}{2} (a + b) h$ where a and b are the lengths of the parallel sides and h is the perpendicular distance between the parallel sides.

Roots of quadratic equations If $ax^2 + bx + c = 0$,

$$\text{then } x = \frac{-b \pm \sqrt{b^2 - 4ac}}{2a}$$

Trigonometric ratios

$$\sin \theta = \frac{\text{opposite side}}{\text{hypotenuse}}$$

$$\cos \theta = \frac{\text{adjacent side}}{\text{hypotenuse}}$$

$$\tan \theta = \frac{\text{opposite side}}{\text{adjacent side}}$$

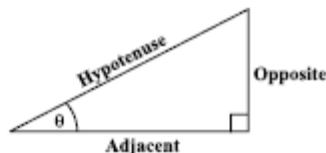

Area of triangle Area of $\Delta = \frac{1}{2} bh$ where b is the length of the base and h is the perpendicular height.

$$\text{Area of } \Delta ABC = \frac{1}{2} ab \sin C$$

$$\text{Area of } \Delta ABC = \sqrt{s(s-a)(s-b)(s-c)}$$

$$\text{where } s = \frac{a+b+c}{2}$$

Sine rule

$$\frac{a}{\sin A} = \frac{b}{\sin B} = \frac{c}{\sin C}$$

Cosine rule

$$a^2 = b^2 + c^2 - 2bc \cos A$$

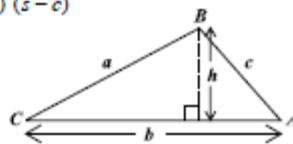

GO ON TO THE NEXT PAGE



SECTION I

Answer ALL the questions in this section.

All working must be clearly shown.

1. (a) Using a calculator, or otherwise, calculate the EXACT value of

$$(12.8)^2 - (30 \div 0.375).$$

(3 marks)



- (b) Mark spends $\frac{3}{8}$ of his monthly income on housing. Of the REMAINDER, he spends $\frac{1}{3}$ on food and saves what is left.

(i) Calculate the fraction of his monthly income spent on food.

(2 marks)

(ii) Calculate the fraction of his monthly income that he saved.

(2 marks)



- (c) (i) At Bank A, US \$1.00 = BD \$1.96. Calculate the value of US \$700 in BD\$.
US\$ means United States dollars and BD\$ means Barbados dollars.

(2 marks)

- (ii) At Bank B, the value of US \$700 is BD \$1 386. Calculate the value of US \$1.00 in BD\$ at this bank.

(2 marks)

Total 11 marks



2. (a) Simplify

$$p^3q^2 \times pq^5.$$

(2 marks)

- (b) Express as a single fraction in its simplest form

$$\frac{a}{5} + \frac{3a}{2}.$$

(2 marks)



(c) Factorize completely:

(i) $x^2 - 5x + 4$

(2 marks)

(ii) $m^2 - 4n^2$

(2 marks)



- (d) (i) Solve for x
 $2x - 7 \leq 3$.

(1 mark)

- (ii) If x is a positive integer, list the possible values of x .

(1 mark)



(e) Find the value of $2\pi\sqrt{\frac{l}{g}}$

where $\pi = 3.14$, $l = 0.625$ and $g = 10$.

(2 marks)

Total 12 marks



3. (a) In a survey of 30 families, the findings were that:

15 families owned dogs

12 families owned cats

x families owned BOTH dogs and cats

8 families owned NEITHER dogs NOR cats

- (i) Given that:

$U = \{\text{families in the survey}\}$

$C = \{\text{families who owned cats}\}$

$D = \{\text{families who owned dogs}\}$

Use the given information to complete the Venn diagram below.

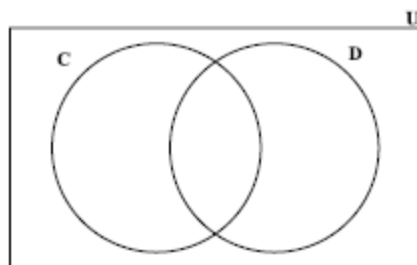

(4 marks)

- (ii) Write an expression, in x , which represents the TOTAL number of families in the survey.

(1 mark)

- (iii) Write an equation which may be used to solve for x .

(1 mark)



- (b) The diagram below, not drawn to scale, shows parallelogram $ABCD$.

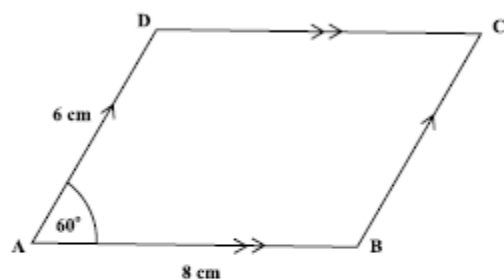

Using a ruler, a pencil and a pair of compasses only, construct parallelogram $ABCD$ with $AB = 8$ cm, $AD = 6$ cm and $\angle DAB = 60^\circ$.

Marks will be awarded for construction lines clearly shown.

(6 marks)

Total 12 marks

GO ON TO THE NEXT PAGE



4. An electrician charges a fixed fee for a house visit plus an additional charge based on the length of time spent on the job.

The total charges, y , are calculated using the equation $y = 40x + 75$, where x represents the time in hours spent on the job.

- (a) Complete the table of values for the equation $y = 40x + 75$.

x (time in hours)	0	1	2	3	4	5	6
y (total charges in \$)	75	115		195		275	315

(2 marks)

- (b) On the grid on page 13, using a scale of 2 cm to represent one hour on the x -axis and 2 cm to represent 50 dollars on the y -axis, plot the 7 pairs of values shown in your completed table. Draw a straight line through all plotted points. (5 marks)

- (c) Using your graph, determine

- (i) the total charges when the job took 4.5 hours

(2 marks)

- (ii) the time, in hours, spent on a job if the total charges were \$300

(2 marks)

- (iii) the fixed charge for a visit.

(1 mark)

Draw lines on your graph to show how the values for (c) (i) and (c) (ii) were obtained.

Total 12 marks

GO ON TO THE NEXT PAGE



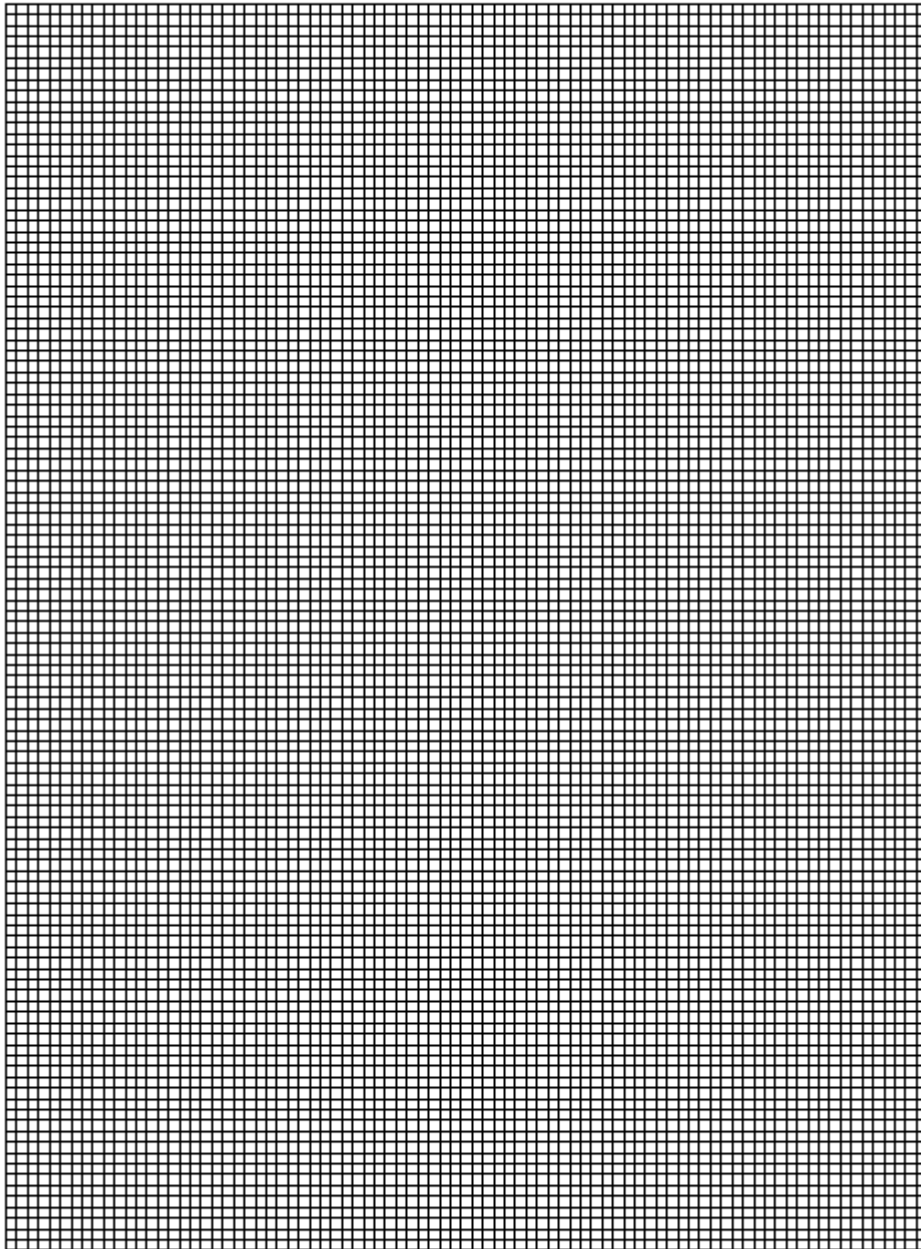

GO ON TO THE NEXT PAGE

01234020/JANUARY/F 2015



0123402015

5. The diagram below shows $\triangle LMN$ and its image $\triangle PQR$ after a transformation.

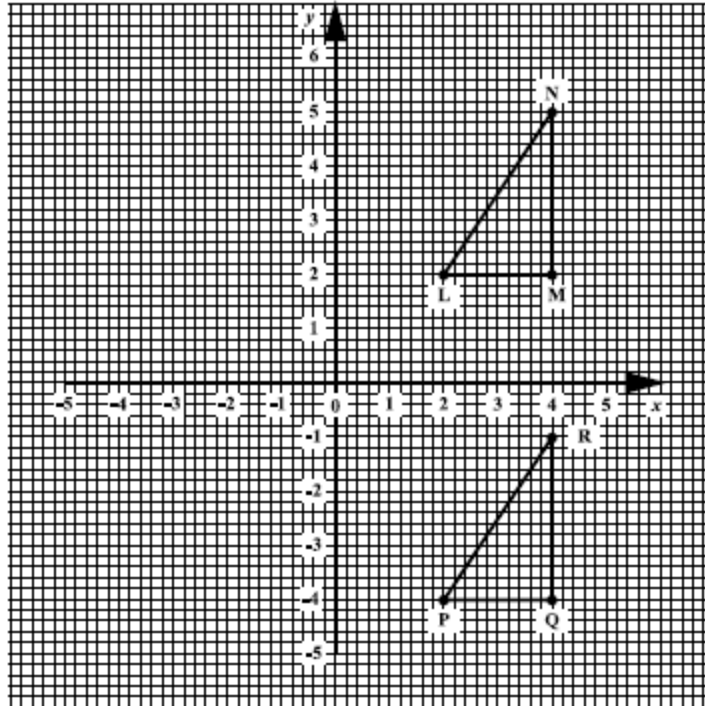

- (i) Write down the coordinates of N (1 mark)
- (ii) On the grid above, draw $\triangle FGH$, the reflection of $\triangle LMN$ in the y -axis. (4 marks)
- (iii) Using vector notation, describe the transformation which maps $\triangle LMN$ onto $\triangle PQR$.

.....

.....

(2 marks)



(iv) Complete the following statement:

$\triangle PQR$ is mapped onto $\triangle FGH$ by a combination of two transformations. First, $\triangle PQR$ is mapped onto $\triangle LMN$ by a , parallel to the ; then $\triangle LMN$ is mapped onto $\triangle FGH$ by a in the
(3 marks)

(v) $\triangle PQR$ and $\triangle FGH$ are congruent.
State TWO reasons why they are congruent.

.....
.....
.....
.....
.....

(2 marks)

Total 12 marks



6. (a) The diagram below is a scale drawing of the side view of a building. Q is the midpoint of KN , and $\angle KLM = \angle LMN = 90^\circ$.

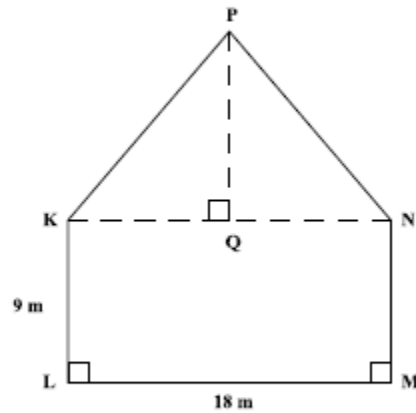

- (i) Measure and state the length of PQ on the drawing.

$PQ =$ (1 mark)

- (ii) Determine the scale of the drawing.

The scale is 1: (2 marks)

- (iii) Calculate the actual area of the face $LMNPK$ on the building.

(4 marks)

GO ON TO THE NEXT PAGE



- (b) The diagram below, **not drawn to scale**, shows the plan of a swimming pool in the shape of a rectangle and two semicircles. The rectangle has dimensions 8 metres by 3.5 metres.

[Use $\pi = \frac{22}{7}$]

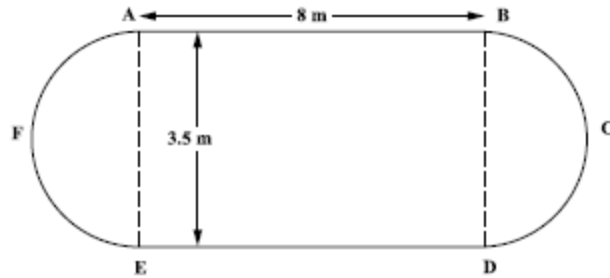

- (i) State the length of the diameter of the semicircle, AFE .

(1 mark)

- (ii) Calculate the perimeter of the swimming pool.

(3 marks)

Total 11 marks

GO ON TO THE NEXT PAGE



7. The masses of 60 parcels collected at a post office were grouped and recorded as shown in the histogram below.

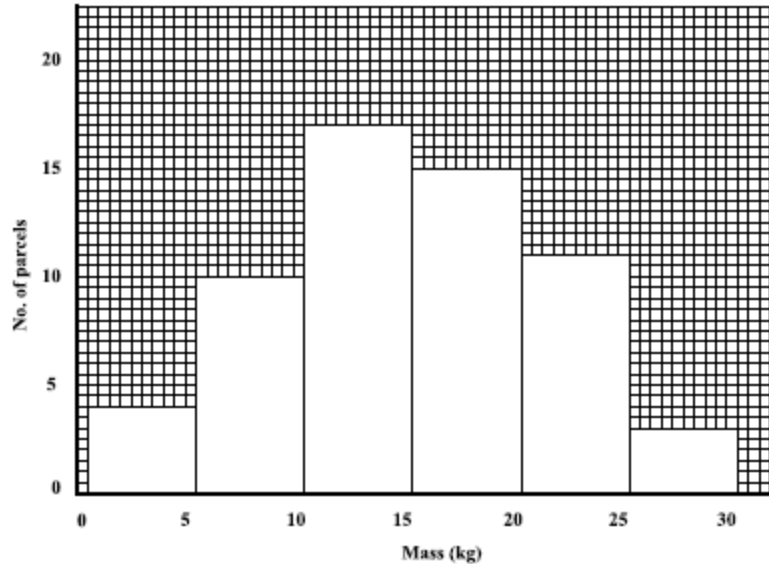

- (a) (i) Complete the table below to show the information given in the histogram. (2 marks)
- (ii) Complete the column headed "Cumulative Frequency". (1 mark)

Mass (kg)	No. of Parcels	Cumulative Frequency
1-5	4	4
6-10	10	14
11-15	17	31
16-20		46
21-25	11	
26-30		60

- (b) On the grid provided on page 19, using a scale of 2 cm to represent 5 kg on the x-axis and 2 cm to represent 10 parcels on the y-axis, draw the cumulative frequency curve for the data. (5 marks)



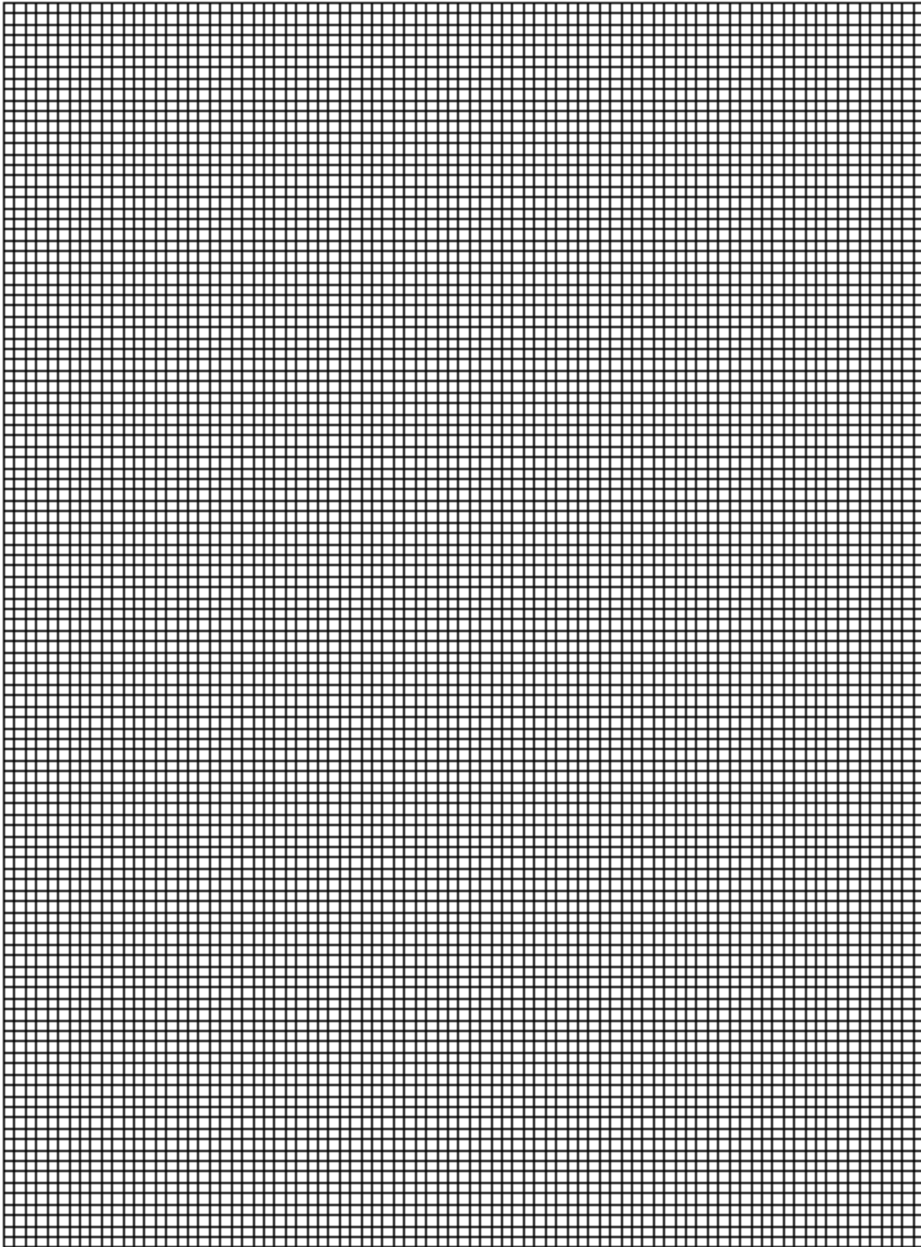

GO ON TO THE NEXT PAGE

01234020/JANUARY/F 2015



0123402021

- (c) Use the graph drawn at (b) to estimate the median mass of the parcels.

Draw lines on your graph to show how this estimate was obtained. (2 marks)

Total 10 marks



8. The diagram below shows the first three figures in a sequence of figures.

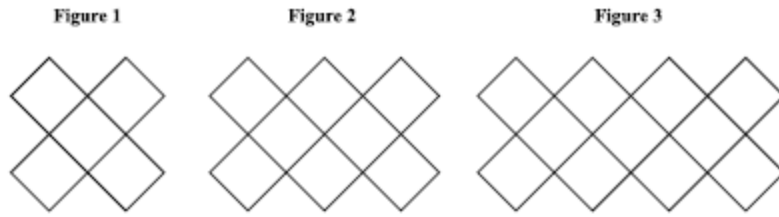

- (a) Draw the fourth figure in the sequence.

(2 marks)

GO ON TO THE NEXT PAGE



- (b) The table below shows the number of squares in each figure. Study the pattern in the table and complete the table by inserting the missing values in the rows numbered (i), (ii), (iii) and (iv).

	Figure (n)	No. of Squares	
	1	5	
	2	8	
	3	11	
(i)	4	(1 mark)
(ii)	10	(2 marks)
(iii)	50	(2 marks)
(iv)	n	(3 marks)

Total 10 marks

GO ON TO THE NEXT PAGE



SECTION II

Answer TWO questions in this section.

ALGEBRA AND RELATIONS, FUNCTIONS AND GRAPHS

9. (a) The functions $f(x)$ and $g(x)$ are defined as:

$$f(x) = \frac{5x - 4}{3} \qquad g(x) = x^2 - 1$$

- (i) Evaluate $f(7)$.

(1 mark)

- (ii) Write an expression, in terms of x , for $f^{-1}(x)$.

(2 marks)

GO ON TO THE NEXT PAGE



- (ii) Write an expression, in terms of x , for $fg(x)$.

(2 marks)



- (b) (i) Express the quadratic function $f(x) = 3x^2 + 6x - 2$, in the form $a(x + h)^2 + k$, where a , h and k are constants.

(3 marks)

- (ii) Hence, or otherwise, state the minimum value of $f(x) = 3x^2 + 6x - 2$.

(1 mark)



- (iii) State the equation of the axis of symmetry of the function

$$f(x) = 3x^2 + 6x - 2.$$

•

(2 marks)

- (iv) Sketch the graph of $y = 3x^2 + 6x - 2$, showing on your sketch

- a) the intercept on the y -axis
- b) the coordinates of the minimum point.

(4 marks)

Total 15 marks

GO ON TO THE NEXT PAGE



MEASUREMENT, GEOMETRY AND TRIGONOMETRY

10. (a) On the diagram below, not drawn to scale, $RQ = 9$ m, $RS = 12$ m, $ST = 13$ m, $\angle QRS = 60^\circ$ and $\angle SQT = 40^\circ$.

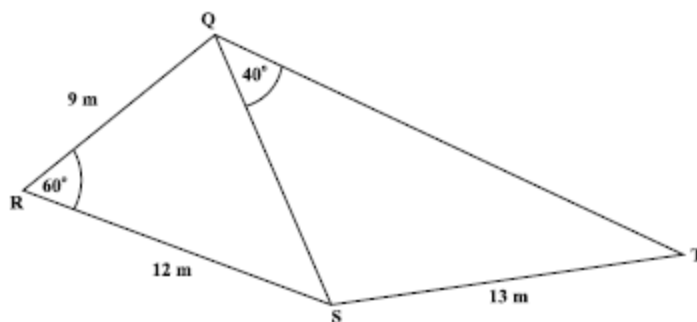

Calculate, correct to 1 decimal place,

- (i) the length QS

- (ii) the measure of $\angle QTS$

(2 marks)

(2 marks)

GO ON TO THE NEXT PAGE



(iii) the area of triangle QRS

(2 marks)

(iv) the perpendicular distance from Q to RS .

(1 mark)



- (b) The diagram below, not drawn to scale, shows a circle with centre O . HJ and HG are tangents to the circle and $\angle JHG = 48^\circ$.

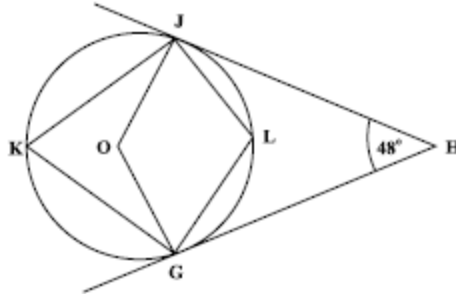

Calculate, giving the reason for each step of your answer, the measure of:

(i) $\angle OJH$

(2 marks)

(ii) $\angle JOG$

(2 marks)



(iii) $\langle JKG$

(2 marks)

(iv) $\langle JLG$

(2 marks)

Total 15 marks



VECTORS AND MATRICES

11. (a) (i) Write the following simultaneous equations

$$3x + 2y = -1$$

$$5x + 4y = 6$$

in the form $AX = B$, where A , X and B are matrices.

(2 marks)

- (ii) Use a matrix method to solve for x and y .

(4 marks)

GO ON TO THE NEXT PAGE



- (b) The diagram below shows two position vectors \vec{OR} and \vec{OS} such that $R(6, 2)$ and $S(-4, 3)$.

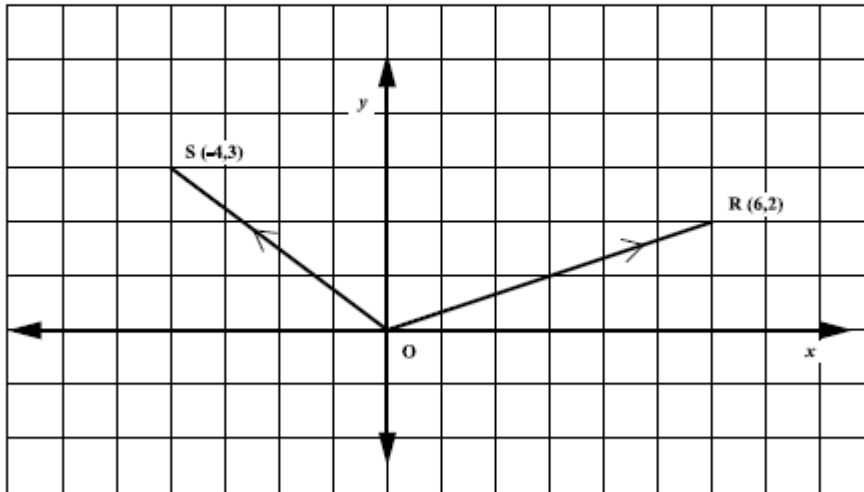

Write as a column vector in the form $\begin{pmatrix} x \\ y \end{pmatrix}$:

(i) \vec{OR}

(ii) \vec{OS}

(1 mark)

(iii) \vec{SR}

(1 mark)

(2 marks)

GO ON TO THE NEXT PAGE



(iv) Find $|\vec{OS}|$.

(1 mark)

(v) Given that $OT = \begin{pmatrix} 2 \\ 5 \end{pmatrix}$, prove that $OSTR$ is a parallelogram.

(4 marks)

Total 15 marks

END OF TEST

IF YOU FINISH BEFORE TIME IS CALLED, CHECK YOUR WORK ON THIS TEST.



0123402036

01234020/JANUARY/F 2015



TEST CODE **01234020**

FORM TP 2015089

MAY/JUNE 2015

**CARIBBEAN EXAMINATIONS COUNCIL
CARIBBEAN SECONDARY EDUCATION CERTIFICATE®
EXAMINATION**

MATHEMATICS

Paper 02 – General Proficiency

2 hours 40 minutes

READ THE FOLLOWING INSTRUCTIONS CAREFULLY.

1. This paper consists of TWO sections: I and II.
2. Section I has EIGHT questions and Section II has THREE questions.
3. Answer ALL questions in Section I, and any TWO questions from Section II.
4. Write your answers in the booklet provided.
5. Do NOT write in the margins.
6. All working MUST be shown clearly.
7. A list of formulae is provided on page 2 of this booklet.
8. If you need to rewrite any answer and there is not enough space to do so on the original page, you must use the extra page(s) provided at the back of this booklet. Remember to draw a line through your original answer.
9. If you use the extra page(s) you MUST write the question number clearly in the box provided at the top of the extra page(s) and, where relevant, include the question part beside the answer.

Required Examination Materials:

Electronic calculator
Geometry set

DO NOT TURN THIS PAGE UNTIL YOU ARE TOLD TO DO SO.

Copyright © 2014 Caribbean Examinations Council
All rights reserved.

01234020/F 2015



0123402003

LIST OF FORMULAE

Volume of a prism	$V = Ah$ where A is the area of a cross-section and h is the perpendicular length.
Volume of cylinder	$V = \pi r^2 h$ where r is the radius of the base and h is the perpendicular height.
Volume of a right pyramid	$V = \frac{1}{3} Ah$ where A is the area of the base and h is the perpendicular height.
Circumference	$C = 2\pi r$ where r is the radius of the circle.
Arc length	$S = \frac{\theta}{360} \times 2\pi r$ where θ is the angle subtended by the arc, measured in degrees.
Area of a circle	$A = \pi r^2$ where r is the radius of the circle.
Area of a sector	$A = \frac{\theta}{360} \times \pi r^2$ where θ is the angle of the sector, measured in degrees.
Area of trapezium	$A = \frac{1}{2} (a + b) h$ where a and b are the lengths of the parallel sides and h is the perpendicular distance between the parallel sides.
Roots of quadratic equations	If $ax^2 + bx + c = 0$,

$$\text{then } x = \frac{-b \pm \sqrt{b^2 - 4ac}}{2a}$$

Trigonometric ratios

$$\sin \theta = \frac{\text{opposite side}}{\text{hypotenuse}}$$

$$\cos \theta = \frac{\text{adjacent side}}{\text{hypotenuse}}$$

$$\tan \theta = \frac{\text{opposite side}}{\text{adjacent side}}$$

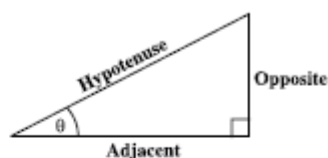

Area of triangle

Area of $\Delta = \frac{1}{2} bh$ where b is the length of the base and h is the perpendicular height.

$$\text{Area of } \Delta ABC = \frac{1}{2} ab \sin C$$

$$\text{Area of } \Delta ABC = \sqrt{s(s-a)(s-b)(s-c)}$$

$$\text{where } s = \frac{a+b+c}{2}$$

Sine rule

$$\frac{a}{\sin A} = \frac{b}{\sin B} = \frac{c}{\sin C}$$

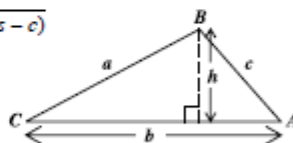

Cosine rule

$$a^2 = b^2 + c^2 - 2bc \cos A$$

GO ON TO THE NEXT PAGE



SECTION I

Answer ALL questions in this section.

All working must be clearly shown.

1. (a) Using a calculator, or otherwise, determine the EXACT value of:

(i) $2\frac{2}{5} - 1\frac{1}{3} + 3\frac{1}{2}$

(1 mark)

(ii) $(4.14 \div 5.75) + (1.62)^2$

(2 marks)



(iii) $2 \times 3.142 \times 1.25$

(iv) $\sqrt{2.89} \times \tan 45^\circ$

(1 mark)

(2 marks)



- (b) The table below shows a shopping bill prepared for Mrs Rowe. The prices of some items are missing.

Shopping Bill		
Item	Unit Cost Price	Total Cost Price
3 kg sugar	X	\$10.80
4 kg rice	Y	Z
2 kg flour	\$1.60	\$3.20

- (i) Calculate the value of X, the cost of 1 kg of sugar.

(1 mark)

- (ii) If the cost price of 1 kg of rice is 80 cents MORE than for 1 kg of flour, calculate the values of Y and Z.

(2 marks)

- (iii) A tax of 10% of the total cost price of the three items is added to Mrs Rowe's bill. What is Mrs Rowe's TOTAL bill including the tax?

(3 marks)

Total 12 marks

GO ON TO THE NEXT PAGE



2. (a) Given that $a = 4$, $b = 2$ and $c = -1$, find the value of:

(i) $a - b + c$

(1 mark)

(ii) $2a^b$

(1 mark)

- (b) A bottle contains 500 ml of orange juice. Write an expression for EACH of the following.

The amount of juice left in the bottle after pouring out

(i) p ml

(1 mark)

(ii) q glasses each containing r ml.

(1 mark)



- (c) Write as a single fraction, as simply as possible

$$\frac{2k}{3} + \frac{2-k}{5}$$

(2 marks)

- (d) Four mangoes and two pears cost \$24.00, while two mangoes and three pears cost \$16.00.

- (i) Write a pair of simultaneous equations in x and y to represent the information given above.

(2 marks)

- (ii) State clearly what x and y represent.

x represents

.....

y represents

.....

(1 mark)



(e) Factorize completely:

(i) $a^3 - 12a$

(1 mark)

(ii) $2x^2 - 5x + 3$

(2 marks)

Total 12 marks



3. (a) The Venn diagram below shows the number of students who play the guitar (G) or the violin (V) in a class of 40 students.

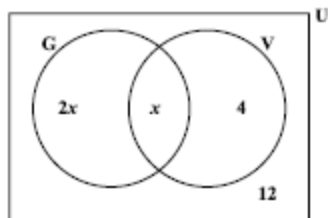

- (i) How many students play neither the guitar nor the violin?

(1 mark)

- (ii) Write an expression, in terms of x , which represents the TOTAL number of students in the class.

(1 mark)

- (iii) Write an equation which may be used to determine the total number of students in the class.

(1 mark)

- (iv) How many students play the guitar?

(2 marks)

GO ON TO THE NEXT PAGE



- (b) (i) Using a ruler, a pencil and a pair of compasses, construct triangle ABC with $AB = 9$ cm, angle $ABC = 90^\circ$ and $BC = 6$ cm.

(4 marks)

- (ii) Measure and state the size of angle BAC.

(1 mark)

- (iii) On the diagram, show the point D such that ABCD is a parallelogram.

(2 marks)

Total 12 marks



4. A graph sheet is provided for this question.

The table below is designed to show values of x and y for the function $y = x^2 - 2x - 3$ for integer values of x from -2 to 4 .

x	-2	-1	0	1	2	3	4
y	5		-3	-4	-3		5

- (a) Complete the table for the function $y = x^2 - 2x - 3$. (2 marks)
- (b) On the graph on page 13, plot the graph of $y = x^2 - 2x - 3$ using a scale of 2 cm to represent 1 unit on the x -axis and 1 cm to represent 1 unit on the y -axis. (4 marks)
- (c) On the graph on page 13, draw a smooth curve passing through the points on your graph. (1 mark)
- (d) Complete the following sentences using information from your graph.
- (i) The values of x for which $x^2 - 2x - 3 = 0$ are and (1 mark)
- (ii) The minimum value of $x^2 - 2x - 3$ is (1 mark)
- (iii) The equation of the line of symmetry of the graph of $y = x^2 - 2x - 3$ is (1 mark)

Total 10 marks



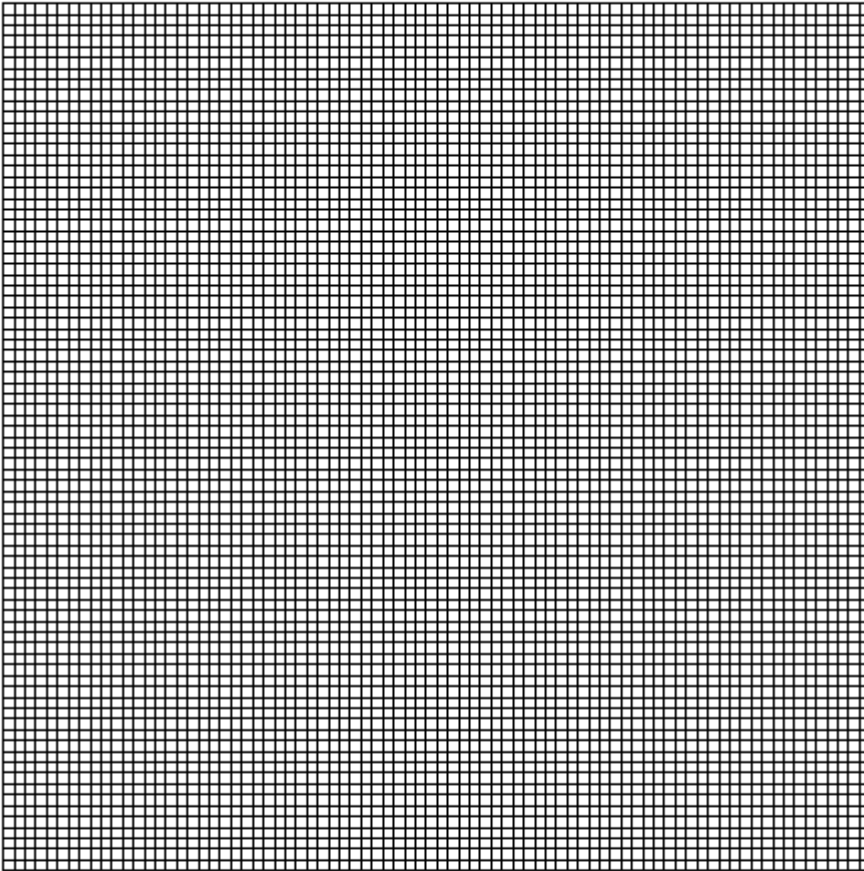

5. (a) A car is travelling at a constant speed of 54 km/h.
- (i) Calculate the distance it travels in $2\frac{1}{4}$ hours.

(1 mark)

- (ii) Calculate the time, in seconds, it takes to travel 315 metres, given that

$$1 \text{ km/h} = \frac{5}{18} \text{ m/s.}$$

(2 marks)

- (b) Write the following scales in the form 1 : x.

(i) 1 millimetre = 1 metre

(1 mark)

(ii) 2 cm = 6 m

(1 mark)



- (c) The map shown below is drawn on a grid of 1 cm squares. P , Q , R and S are four tracking stations. The scale of the map is 1:2 000.

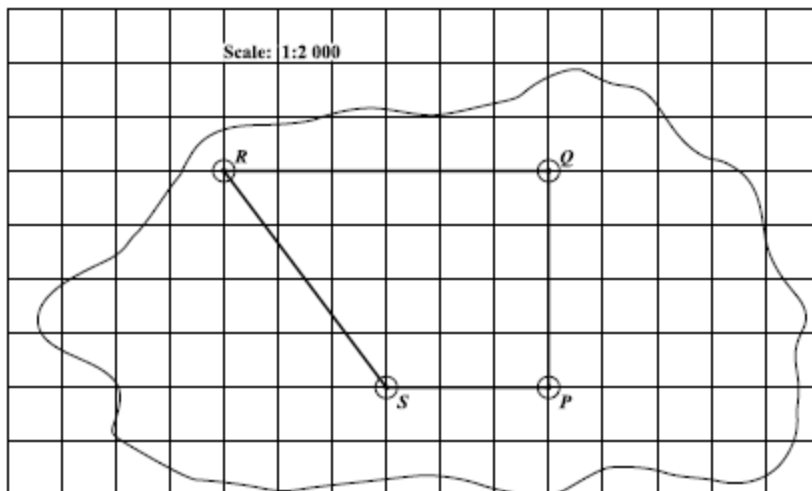

- (i) Determine, in centimetres, the distance from Q to R on the map.
 $QR = \dots\dots\dots$ cm (1 mark)
- (ii) Determine, by counting, the area in square centimetres of the plane $PQRS$ on the map.
 (2 marks)
- (iii) Calculate the ACTUAL distance, in kilometres, between Q and R .
 (2 marks)



- (iv) Calculate the ACTUAL area, in square metres, of the plane PQRS.

(2 marks)

Total 12 marks



6. (a) The diagram below, not drawn to scale, shows two cylindrical water tanks, A and B. Tank B has base diameter 8 m and height 5 m. Both tanks are filled with water.

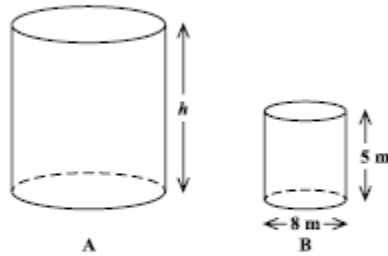

Take $\pi = 3.14$.

- (i) Calculate the volume of water in Tank B.

(2 marks)

- (ii) If the area of the base of A is 314 m^2 , calculate the length of the radius of Tank A.

(1 mark)



- (iii) Tank A holds 8 times as much water as Tank B. Calculate the height, h , of Tank A.

(2 marks)



- (b) The diagram below shows triangle PQR and its image, triangle $P'Q'R'$, after an enlargement centred at the point C on the diagram.

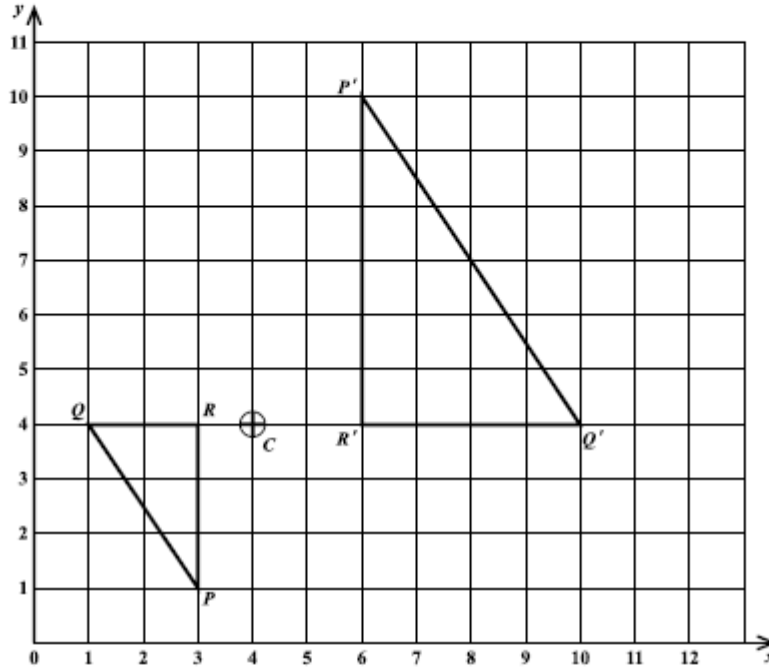

Use the information from the diagram to complete the statements below.

(i) The size of the scale factor is (1 mark)

(ii) The scale factor is negative because

.....

..... (1 mark)



(iii) The length of PQ is $\sqrt{13}$ units, therefore,
the length of $P'Q'$ is units.

(1 mark)

(iv) The area of triangle PQR is square units.

(1 mark)

(v) The area of $P'Q'R'$ is times the area of triangle PQR which is
..... square units. (2 marks)

Total 11 marks



7. The line graph below shows the monthly sales, in thousands of dollars, at a car dealership for the period July to November 2014.

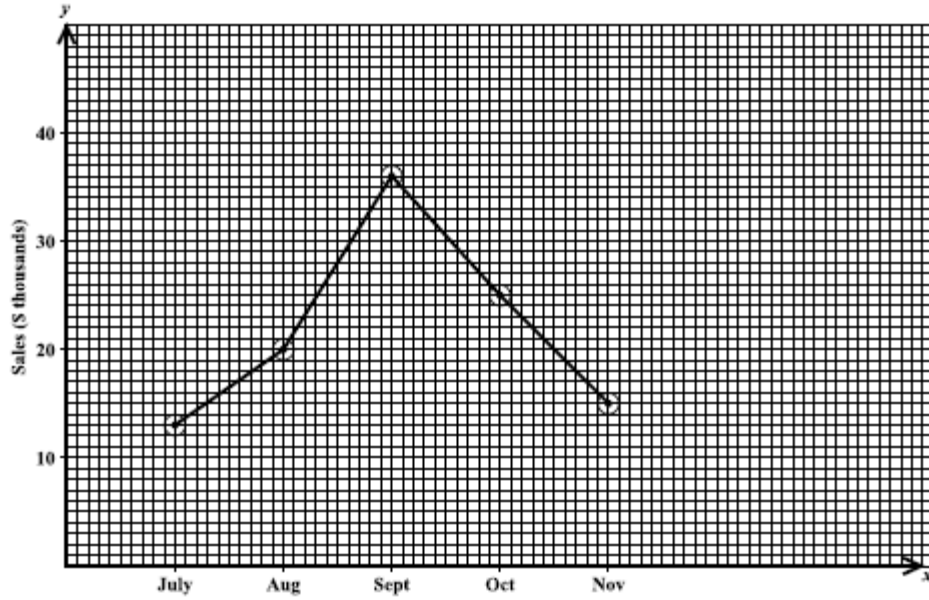

- (a) Complete the table below to show the sales for EACH month.

Month	July	August	September	October	November
Sales in \$ Thousands	13		36		

(2 marks)



- (b) (i) Between which TWO consecutive months was there the GREATEST increase in sales?

..... and
(1 mark)

- (ii) Between which TWO consecutive months was there the SMALLEST increase in sales?

..... and
(1 mark)

- (iii) What feature of the line graph enables you to infer that the increase in sales between two consecutive months was the greatest or the smallest?

.....
.....
.....
.....
(2 marks)

- (c) Calculate the mean monthly sales for the period July to November 2014.

(2 marks)

- (d) The TOTAL sales for the period July to December was \$130 000.

- (i) Calculate the sales, in dollars, for the month of December.

(1 mark)

- (ii) Complete the line graph to show the sales for December. (2 marks)

Total 11 marks

GO ON TO THE NEXT PAGE



8. A sequence of figures is made up of equilateral triangles, called unit triangles with unit sides. The first three figures in the sequence are shown below.



Figure 1



Figure 2



Figure 3

- (a) Draw Figure 4 of the sequence.

(2 marks)



- (b) Study the patterns of numbers in each row of the table below. Each row relates to one of the figures in the sequence of figures. Some rows have not been included in the table.

Complete the rows numbered (i), (ii), (iii) and (iv).

	Figure	Number of Unit Triangles	Number of Unit Sides	
	1	1	$\frac{(3 \times 1)(1+1)}{2} = 3$	
	2	4	$\frac{(3 \times 2)(2+1)}{2} = 9$	
	3	9	$\frac{(3 \times 3)(3+1)}{2} = 18$	
(i)	4			(2 marks)
(ii)		144		(2 marks)
(iii)	25			(2 marks)
(iv)	n			(2 marks)

Total 10 marks



SECTION II

Answer TWO questions in this section.

ALGEBRA AND RELATIONS, FUNCTIONS AND GRAPHS

9. (a) A graph sheet is provided for this question.

A teacher marks an examination out of a maximum of 120 marks. The marks are then converted to percentages.

- (i) Calculate the percentage for a student who scores

- 60 marks

- 120 marks.

(2 marks)

- (ii) On the graph sheet on page 27, plot a graph to show the information in (i).
(2 marks)

- (iii) A candidate is awarded 95 marks on the examination. Use the graph drawn at (ii) to determine the candidate's percentage.

Draw lines on your graph to show how the percentage was obtained.

Percentage:
(1 mark)

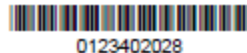

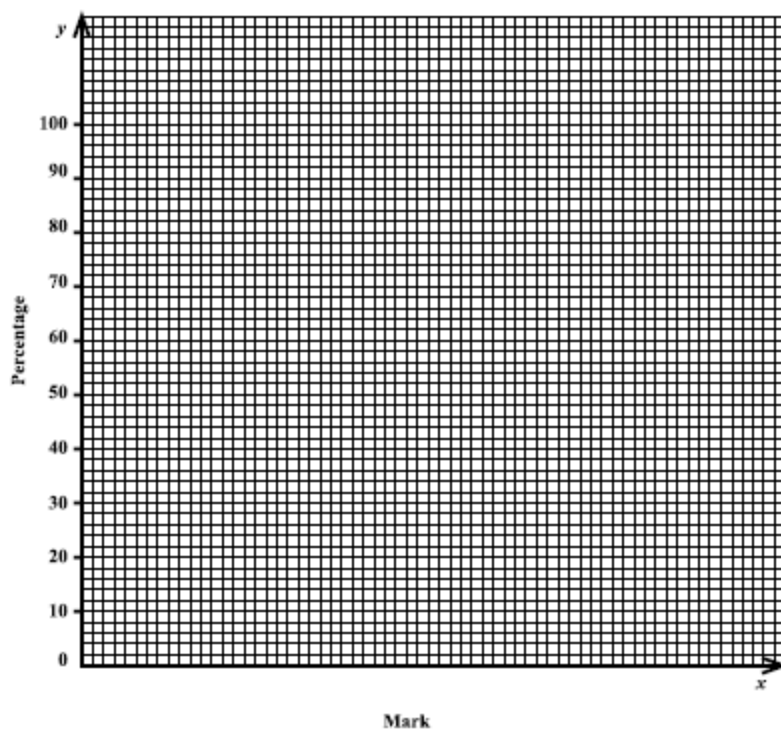

- (iv) A candidate is awarded a Grade A if her percentage is 85% or more. Use the graph drawn at (ii) to determine the minimum mark the candidate needs to be awarded a Grade A.

Draw lines on your graph to show how the percentage was obtained.

Minimum mark: (2 marks)



- (b) The functions $f(x)$ and $g(x)$ are defined as

$$f(x) = 3x + 2 \quad g(x) = \frac{x^2 - 1}{3}$$

- (i) Evaluate $g(5)$.

(2 marks)

- (ii) Write an expression in terms of x for $f^{-1}(x)$.

(2 marks)

- (iii) Write an expression for $g \circ f(x)$, in the form $(x + a)(x + b)$, where a and $b \in \mathbb{R}$.

(4 marks)

Total 15 marks

GO ON TO THE NEXT PAGE



MEASUREMENT, GEOMETRY AND TRIGONOMETRY

10. (a) The diagram below, not drawn to scale, shows a vertical tower, BT , with a flagpole, TP , mounted on it. A point R is on the same horizontal ground as B , such that $RB = 60$ m, and the angles of elevation of T and P from R are 35° and 42° , respectively.

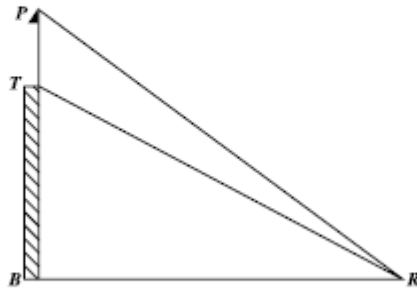

- (i) Label the diagram to show
- the distance 60 m
 - the angles of 35° and 42°
 - any right angle(s). (3 marks)
- (ii) Calculate the length of the flagpole, giving your answer to the nearest metre.

(4 marks)



- (b) The diagram below, not drawn to scale, shows the relative positions of three fishing boats, K , L and M . L is on a bearing of 040° from K and M is due south of L . $LM = 120$ km and $KL = 80$ km.

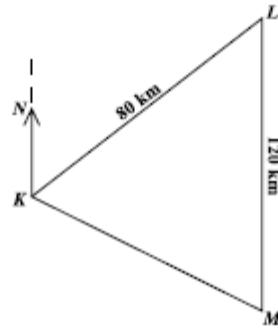

- (i) On the diagram show the bearing of 040° . (1 mark)
- (ii) Calculate the measure of $\angle KLM$.

(1 mark)

- (iii) Calculate the length, to the nearest kilometre, of KM .

(3 marks)



(iv) Calculate the measure of $\angle LKM$ to the nearest degree.

(2 marks)

(v) Calculate the bearing of M from K .

(1 mark)

Total 15 marks



VECTORS AND MATRICES

11. (a) (i) Calculate the matrix product \mathbf{AB} where $\mathbf{A} = \begin{pmatrix} 1 & 1 \\ 2 & 3 \end{pmatrix}$ and $\mathbf{B} = \begin{pmatrix} 1 & 2 \\ 0 & 1 \end{pmatrix}$.

(2 marks)

- (ii) Show that the matrix product of \mathbf{A} and \mathbf{B} is NOT commutative, that is, $\mathbf{AB} \neq \mathbf{BA}$.

(2 marks)

- (iii) Find \mathbf{A}^{-1} , the inverse of \mathbf{A} .

(2 marks)



(iv) Given that $M = \begin{pmatrix} 2x & 2 \\ 9 & 3 \end{pmatrix}$, calculate the value(s) of x for which $|M| = 0$.

(2 marks)

(b) The position vectors of the points R, S and T, relative to an origin, O, are $\begin{pmatrix} -3 \\ 4 \end{pmatrix}$, $\begin{pmatrix} 1 \\ 1 \end{pmatrix}$ and $\begin{pmatrix} 5 \\ -2 \end{pmatrix}$ respectively.

(i) Calculate the value of $|\overrightarrow{OR}|$.

(2 marks)

(ii) Express in the form $\begin{pmatrix} x \\ y \end{pmatrix}$, the vectors \overrightarrow{RS} and \overrightarrow{ST} .

$$\overrightarrow{RS} =$$

$$\overrightarrow{ST} =$$

(3 marks)

- (iii) Using the results of combining the vectors in (b) (ii) on page 33, justify that RS is parallel to ST and that RST is a straight line.

(2 marks)

Total 15 marks

END OF TEST

IF YOU FINISH BEFORE TIME IS CALLED, CHECK YOUR WORK ON THIS TEST.



0123402036

01234020/F 2015



TEST CODE **01234020**

FORM TP 2016017

JANUARY 2016

**CARIBBEAN EXAMINATIONS COUNCIL
CARIBBEAN SECONDARY EDUCATION CERTIFICATE®
EXAMINATION**

MATHEMATICS

Paper 02 – General Proficiency

2 hours 40 minutes

READ THE FOLLOWING INSTRUCTIONS CAREFULLY.

1. This paper consists of TWO sections: I and II.
2. Section I has EIGHT questions and Section II has THREE questions.
3. Answer ALL questions in Section I and any TWO questions from Section II.
4. Write your answers in the booklet provided.
5. Do NOT write in the margins.
6. All working MUST be clearly shown.
7. A list of formulae is provided on page 4 of this booklet.
8. If you need to rewrite any answer and there is not enough space to do so on the original page, you must use the extra page(s) provided at the back of this booklet. Remember to draw a line through your original answer.
9. If you use the extra page(s) you MUST write the question number clearly in the box provided at the top of the extra page(s) and, where relevant, include the question part beside the answer.

Required Examination Materials

Electronic calculator
Geometry set

DO NOT TURN THIS PAGE UNTIL YOU ARE TOLD TO DO SO.

Copyright © 2014 Caribbean Examinations Council
All rights reserved.

01234020/JANUARY/F 2016



0123402003

LIST OF FORMULAE

Volume of a prism	$V = Ah$ where A is the area of a cross section and h is the perpendicular length.
Volume of cylinder	$V = \pi r^2 h$ where r is the radius of the base and h is the perpendicular height.
Volume of a right pyramid	$V = \frac{1}{3}Ah$ where A is the area of the base and h is the perpendicular height.
Circumference	$C = 2\pi r$ where r is the radius of the circle.
Arc length	$S = \frac{\theta}{360} \times 2\pi r$ where θ is the angle subtended by the arc, measured in degrees.
Area of a circle	$A = \pi r^2$ where r is the radius of the circle.
Area of a sector	$A = \frac{\theta}{360} \times \pi r^2$ where θ is the angle of the sector, measured in degrees.
Area of trapezium	$A = \frac{1}{2}(a + b)h$ where a and b are the lengths of the parallel sides and h is the perpendicular distance between the parallel sides.
Roots of quadratic equations	If $ax^2 + bx + c = 0$,

$$\text{then } x = \frac{-b \pm \sqrt{b^2 - 4ac}}{2a}$$

Trigonometric ratios

$$\sin \theta = \frac{\text{opposite side}}{\text{hypotenuse}}$$

$$\cos \theta = \frac{\text{adjacent side}}{\text{hypotenuse}}$$

$$\tan \theta = \frac{\text{opposite side}}{\text{adjacent side}}$$



Area of triangle

Area of $\Delta = \frac{1}{2}bh$ where b is the length of the base and h is the perpendicular height.

$$\text{Area of } \Delta ABC = \frac{1}{2}ab \sin C$$

$$\text{Area of } \Delta ABC = \sqrt{s(s-a)(s-b)(s-c)}$$

$$\text{where } s = \frac{a+b+c}{2}$$

Sine rule

$$\frac{a}{\sin A} = \frac{b}{\sin B} = \frac{c}{\sin C}$$

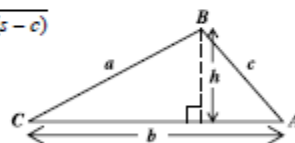

Cosine rule

$$a^2 = b^2 + c^2 - 2bc \cos A$$

GO ON TO THE NEXT PAGE



SECTION I

Answer ALL questions in this section.

All working must be clearly shown.

1. (a) Using a calculator, or otherwise, calculate the EXACT value of

$$(3.6 + \sqrt{51.84}) \div 3.75$$

(2 marks)

- (b) The diagram below, not drawn to scale, shows two jars of peanut butter of the same brand.

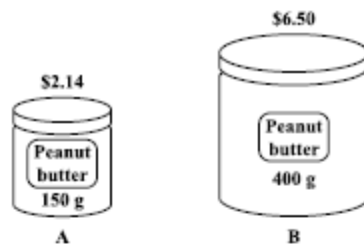

Which of the jars shown above is the BETTER buy?
Show ALL working to support your answer.

(3 marks)



- (c) Thomas invested \$1498 at 6% simple interest per annum.

Calculate:

- (i) The interest, in dollars, earned after six months

(2 marks)

- (ii) The TOTAL amount of money in his account after 3 years

(2 marks)

- (iii) How long it will be before his investment earns \$449.40

(2 marks)

Total 11 marks



2. (a) (i) Solve for x , where x is a real number.

$$8 - x \leq 5x + 2$$

(3 marks)

- (ii) Show your solution to (a) (i) on the number line below.

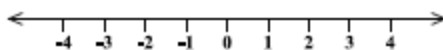

(1 mark)

- (b) Expand and simplify

$$2x(x + 5) - 3(x - 4).$$

(2 marks)



- (c) Simplify

$$\frac{3x^2 \times 4x^3}{2x}$$

(2 marks)

- (d) Write as a single fraction, in its lowest terms,

$$\frac{x+1}{2} + \frac{5-x}{5}$$

(2 marks)

- (e) Factorize completely

$$4x^2 - 4$$

(2 marks)

Total 12 marks



3. (a) The Venn diagram below shows the number of students in Form 5A who have visited Canada (C) or Dominica (D).

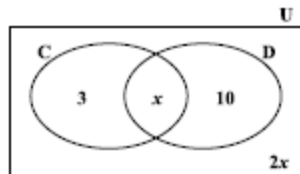

- (i) How many students have visited Dominica ONLY?

 (1 mark)
- (ii) Write an expression, in terms of x , to represent the TOTAL number of students who have visited Canada.

 (1 mark)
- (iii) Given that there are 25 students in Form 5A, calculate the value of x .

 (2 marks)
- (iv) Hence, write down the number of students in each of the following subsets:
- $C \cup D$
 - $C \cap D$
 - $(C \cup D)'$
- (3 marks)



- (b) (i) Using a ruler, a pencil and a pair of compasses, construct accurately, the square EFGH where $EF = 6$ cm.

(Show ALL construction lines and curves.)

(4 marks)

- (ii) Measure, and state in centimetres, the length of the diagonal FH.

FH = cm
(1 mark)

Total 12 marks



4. (a) The diagram below shows a map of an island drawn on a grid of 1 cm squares.

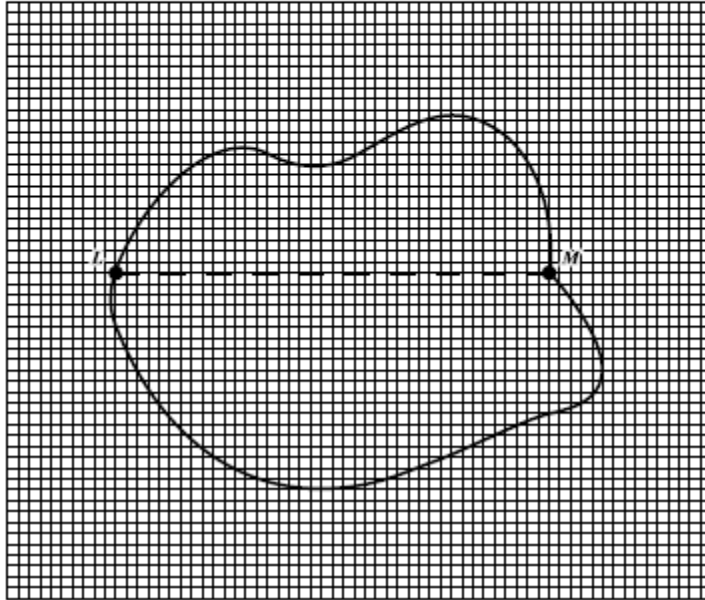

- (i) State, in cm, the length of LM as shown in the diagram.

LM = cm
(1 mark)

- (ii) Estimate, by counting squares, the area of the map shown in the diagram.

(1 mark)



- (iii) On the island, the actual distance LM is 20 km. Complete the following statement:

On the map, 1 cm represents km. (1 mark)

- (iv) Write the scale of the map in the form 1 : x.

(1 mark)

- (v) What distance on the island will be 3 cm on the map?

(1 mark)

- (vi) What area on the island will be represented by 3 cm² on the map?

(2 marks)

GO ON TO THE NEXT PAGE



- (b) The diagram below, **not drawn to scale**, shows a prism with cross section PQRST and length 20 cm. PQRST is made up of a rectangle PQRT and a semicircle RST such that $PQ = 6$ cm and $QR = 5$ cm.

Use $\pi = 3.14$

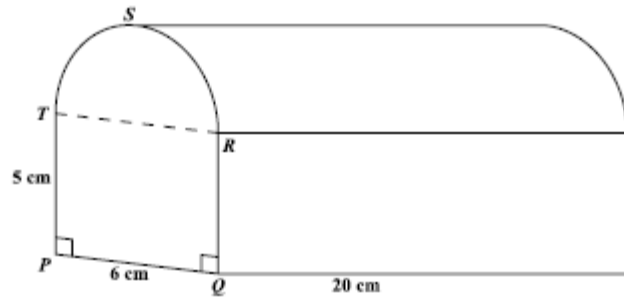

- (i) Calculate the area of the cross section PQRST.

(2 marks)

- (ii) An engineer needs a similar prism whose volume is **NOT** more than 900 cm^3 . Estimate, in cm, the length of the longest prism he can use.

(2 marks)

Total 11 marks

GO ON TO THE NEXT PAGE



5. (a) In the diagram below, not drawn to scale, $ST = 6$ m, $WR = 11.2$ m, $WT = 14.8$ m and angle $WRS = 90^\circ$.

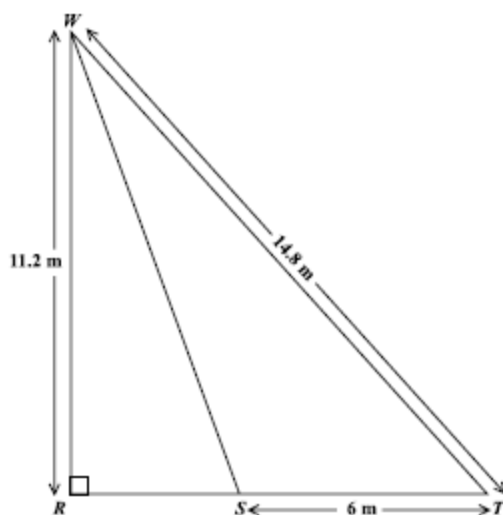

Calculate, giving your answer to 1 decimal place

- (i) the length RS

(2 marks)

- (ii) the measure of angle RTW .

(2 marks)

GO ON TO THE NEXT PAGE



- (b) The graph below shows a triangle ABC and its image $A'B'C'$ after undergoing a single transformation.

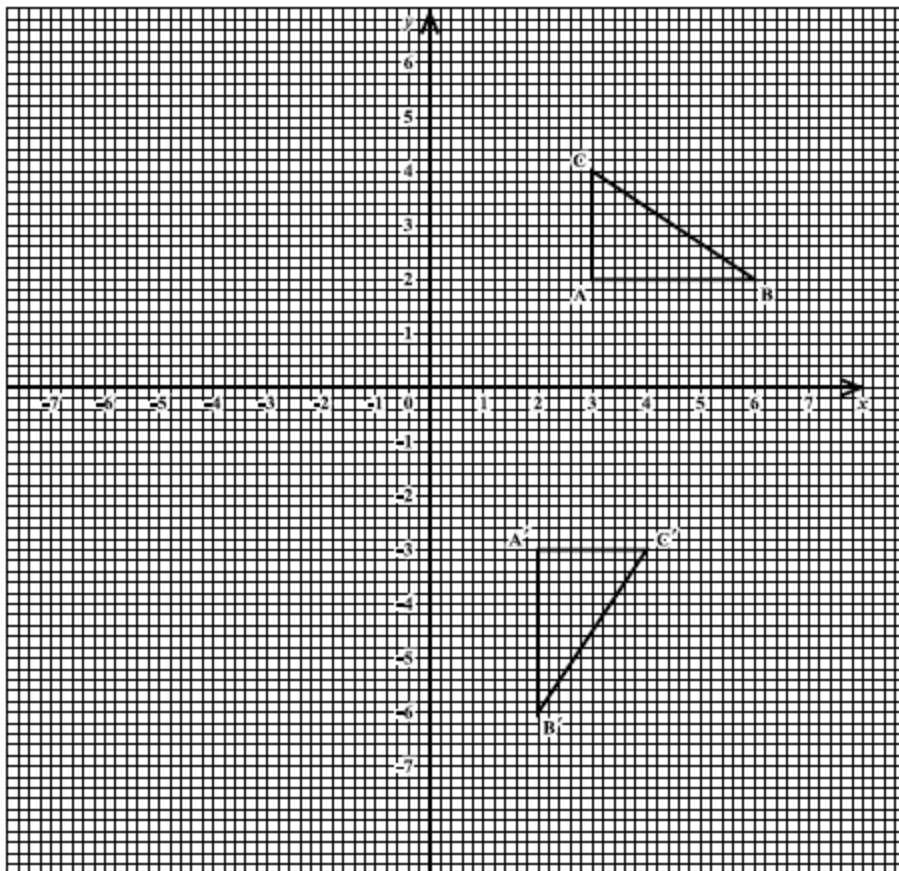

- (i) Write down the coordinates of the vertices of $\triangle ABC$.

(1 mark)

- (ii) Write down the coordinates of the vertices of $\triangle A'B'C'$.

(1 mark)

- (iii) Describe FULLY the transformation that maps triangle ABC onto triangle $A'B'C'$.

.....
.....
.....

(2 marks)

- (iv) On the graph on page 16, draw the line $x = 1$ AND the triangle $A''B''C''$, the image of triangle ABC after a reflection in the line $x = 1$. (3 marks)

- (v) State ONE geometrical relationship among $\triangle ABC$, $\triangle A'B'C'$ and $\triangle A''B''C''$

.....
.....
.....

(1 mark)

Total 12 marks



6. (a) The table below gives the number of cars sold in a country, in hundreds, from 2010 to 2014.

Year	2010	2011	2012	2013	2014
Cars sold (in hundreds)	19	10	26	16	30

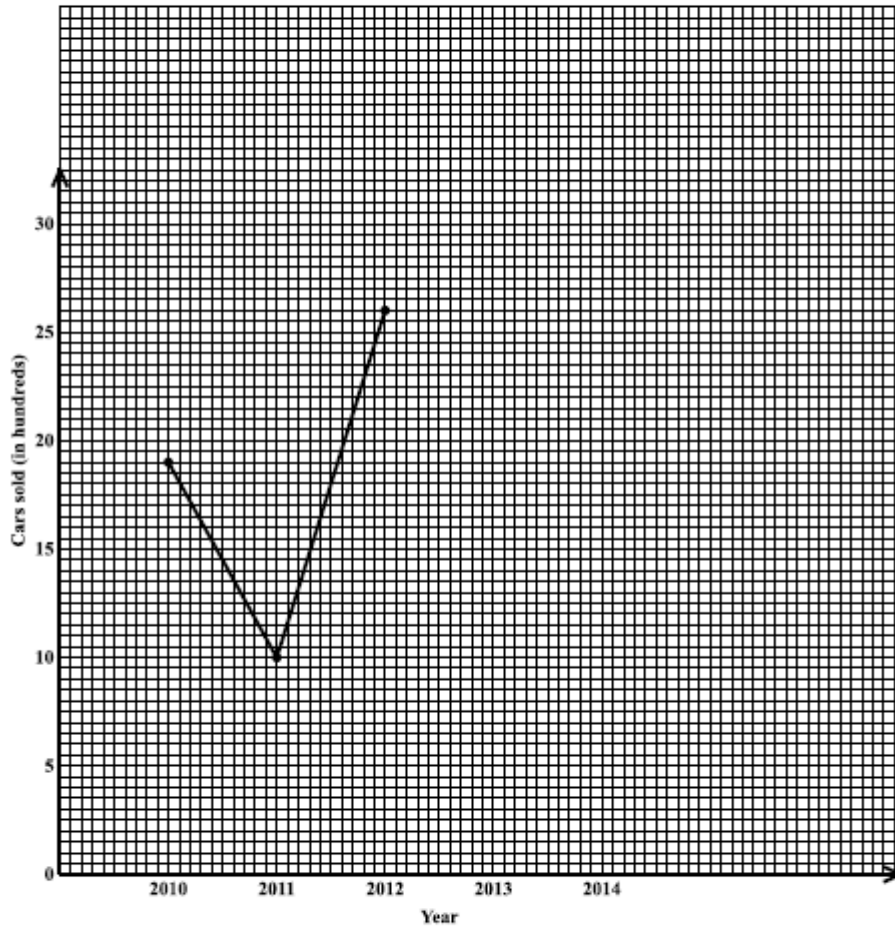

- (i) Complete the line graph on page 18 to represent the given information.
(1 mark)
- (ii) Between which two consecutive years was there the GREATEST increase in cars sold?
.....
(1 mark)
- (iii) What was the TOTAL number of cars sold in the five year period 2010 to 2014?

(2 marks)

- (iv) The mean number of cars sold from 2010 to 2015 was 22.5 hundred. How many cars were sold in 2015?

(2 marks)



- (b) (i) A line JK has equation $2y = 5x + 6$. Determine the gradient of JK.

Gradient of the line JK is
(2 marks)

Another line GH, is perpendicular to JK and passes through the point (5, -1).

- (ii) State the gradient of the line GH.

Gradient of the line GH is
(1 mark)

- (iii) Determine the equation of line GH.

Equation of the line GH is
(2 marks)

Total 11 marks



7. The table below shows how the minutes taken by all students to complete a science experiment were recorded and grouped.

Time (minutes)	Number of Students who Completed (Frequency)	Cumulative Frequency
1–5	1	1
6–10	2	3
11–15	5	
16–20	7	
21–25	10	
26–30	15	
31–35	8	
36–40	2	

- (a) Complete the cumulative frequency column in the table. (2 marks)
- (b) On the grid on page 23, using a scale of 2 cm to represent 5 minutes on the x-axis and 2 cm to represent 5 students on the y-axis, draw a cumulative frequency curve to represent the information in the table. (5 marks)

Using the graph, estimate

- (c) (i) the median time taken to complete the experiment

(2 marks)

- (ii) the probability that a student, chosen at random, took 30 minutes or less to complete the experiment.

(2 marks)

Show on your graph, using broken lines, how these estimates were obtained.

Total 11 marks

GO ON TO THE NEXT PAGE



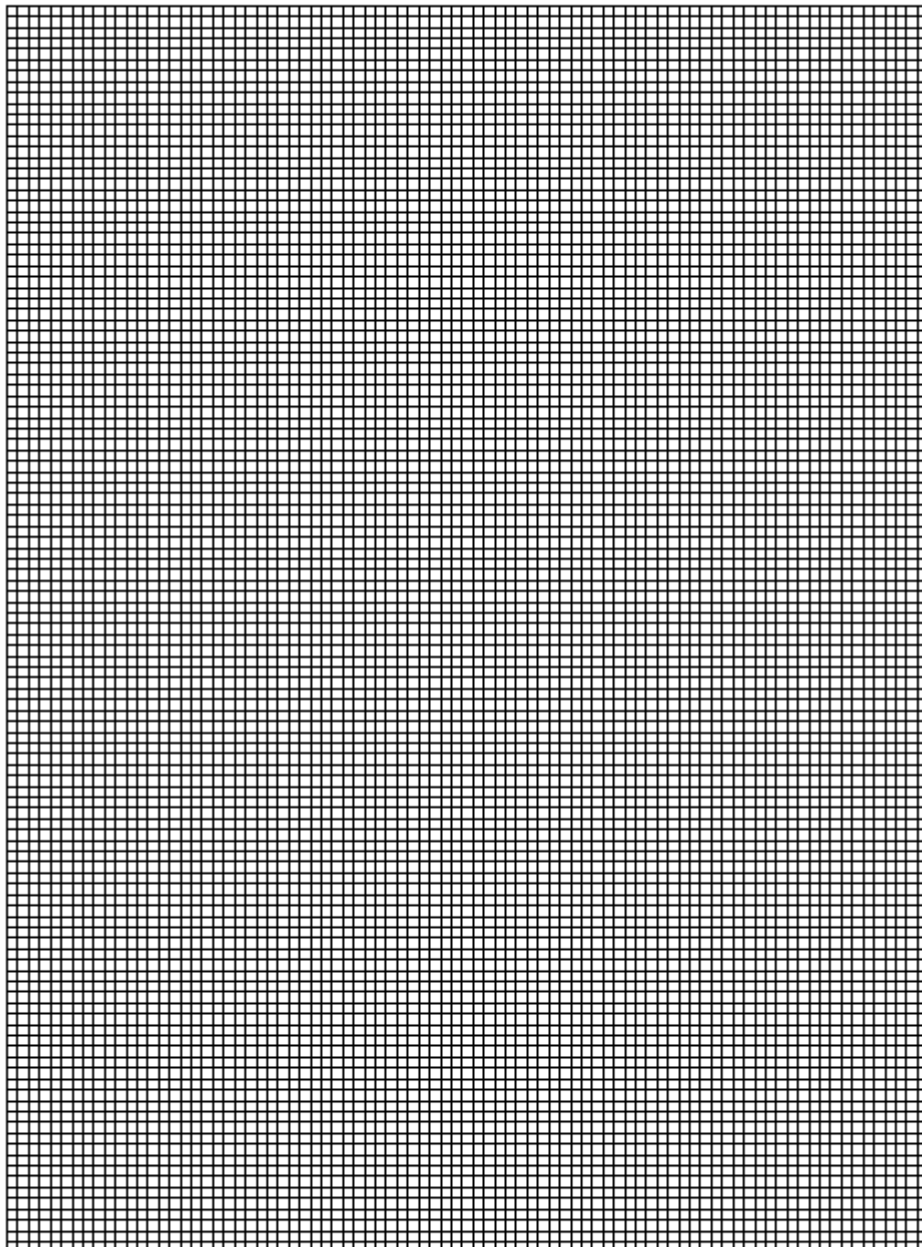

GO ON TO THE NEXT PAGE



8. The diagram below shows the first three figures in a sequence of figures.

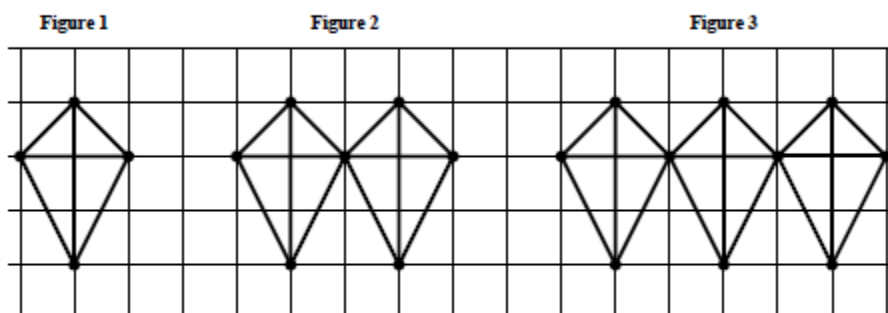

(a) Draw the fourth figure in the sequence.

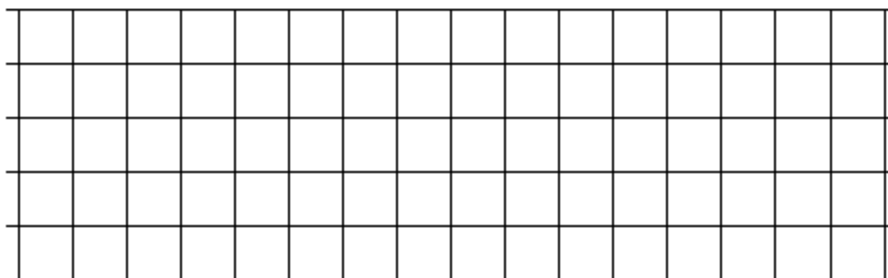

(2 marks)



- (b) The table below shows the number of dots and lines in each figure. Study the pattern in the table and complete the table by inserting the missing values in the rows numbered (i), (ii), (iii) and (iv).

	Figure	Number of Dots	Number of Lines	
	1	4	6	
	2	7	11	
	3	10	16	
(i)	4	(2 marks)
		Entries omitted for Figures 5–9		
(ii)	10	(2 marks)
		Entries omitted for some Figures		
(iii)	49	(2 marks)
		Entries omitted for some Figures		
(iv)	N	(2 marks)

Total 10 marks



SECTION II

Answer TWO questions in this section.

ALGEBRA AND RELATIONS, FUNCTIONS AND GRAPHS

9. (a) The diagram below shows the graph of three lines and a shaded region, S, defined by three inequalities associated with these lines.

The inequality associated with the line $y = 3$ is $y \geq 3$.

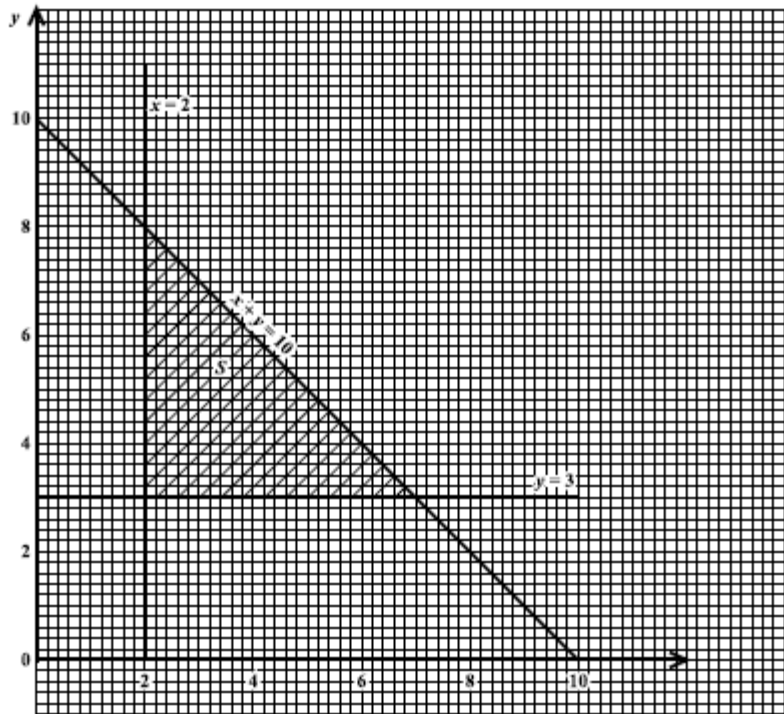

- (i) State the other TWO inequalities which define the shaded region.

.....
(2 marks)



The function $P = 5x + 2y - 3$ satisfies the solution set represented by the closed triangular region.

- (ii) Identify the three pairs of (x, y) values for which P has a maximum or a minimum value.

.....
.....
.....

(2 marks)

- (iii) Which pair of (x, y) values makes P a maximum?

Justify your answer.

P is a maximum at

(3 marks)



- (b) The function $f(x)$ and $g(x)$ are defined as follows

$$f(x) = \frac{3}{2x+1} \text{ and } g(x) = x^2$$

- (i) Evaluate EACH of the following:

• $g\left(\frac{-1}{2}\right)$

• $fg\left(\frac{-1}{2}\right)$

(4 marks)

- (ii) Write an expression in x for $f^{-1}(x)$.

(4 marks)

Total 15 marks

GO ON TO THE NEXT PAGE



MEASUREMENT, GEOMETRY AND TRIGONOMETRY

10. (a) The figure below, not drawn to scale, shows a circle with centre O. The radius of the circle is 21 cm and angle HOK = 40° .

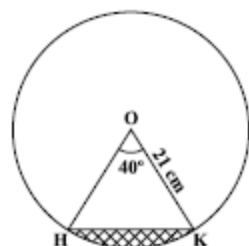

$$\text{Use } \pi = \frac{22}{7}$$

Determine

- (i) the area of the minor sector HOK

(2 marks)

- (ii) the area of triangle HOK

(3 marks)

- (iii) the area of the shaded segment.

(2 marks)



- (b) The diagram below, not drawn to scale, shows a circle with centre O . TAE is a tangent to the circle at point A and angle $AOD = 72^\circ$.

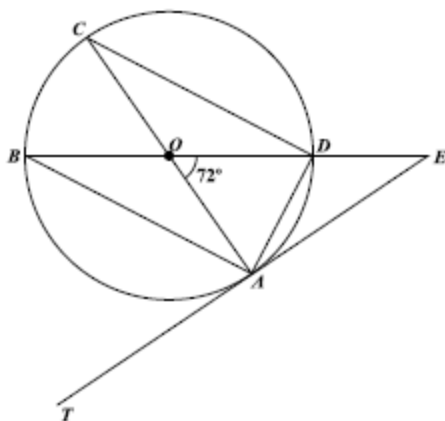

Calculate, giving the reason for each step of your answer, the measure of:

(i) $\angle ADC = \dots\dots\dots$

(2 marks)

(ii) $\angle ACD = \dots\dots\dots$

(2 marks)

(iii) $\angle CAD = \dots\dots\dots$

(2 marks)

(iv) $\angle OEA = \dots\dots\dots$

(2 marks)

Total 15 marks

GO ON TO THE NEXT PAGE



VECTORS AND MATRICES

11. (a) The points A, B and C have coordinates A (-2, 8), B (4, 2) and C (0, 9). M is the midpoint of the line segment AB.

(i) Express EACH of the following in the form $\begin{pmatrix} x \\ y \end{pmatrix}$:

• $\vec{OB} = \dots\dots\dots$

• $\vec{AB} = \dots\dots\dots$

• $\vec{OM} = \dots\dots\dots$

(5 marks)

- (ii) Using a vector method, show that \vec{AC} and \vec{OB} are parallel.

(2 marks)

GO ON TO THE NEXT PAGE



(b) The matrix M is defined as $M = \begin{pmatrix} 2p & -3 \\ 4 & 1 \end{pmatrix}$.

Determine the value of p for which the matrix M is singular.

(2 marks)

(c) A and B are two 2×2 matrices such that $A = \begin{pmatrix} 1 & 2 \\ -4 & 3 \end{pmatrix}$ and $B = \begin{pmatrix} 5 & -1 \\ 0 & 3 \end{pmatrix}$.

(i) Calculate $2A + B$.

(2 marks)

(ii) Determine B^{-1} , the inverse of B .

(2 marks)



(iii) Given that $\begin{pmatrix} 5 & -1 \\ 0 & 3 \end{pmatrix} \begin{pmatrix} x \\ y \end{pmatrix} = \begin{pmatrix} 9 \\ 3 \end{pmatrix}$, calculate the values of x and y .

(2 marks)

Total 15 marks

END OF TEST

IF YOU FINISH BEFORE TIME IS CALLED, CHECK YOUR WORK ON THIS TEST.



0123402033

01234020/JANUARY/F 2016

FORM TP 2016089



TEST CODE 01234020

MAY/JUNE 2016

CARIBBEAN EXAMINATIONS COUNCIL
CARIBBEAN SECONDARY EDUCATION CERTIFICATE®
EXAMINATION

MATHEMATICS

Paper 02 – General Proficiency

2 hours 40 minutes

READ THE FOLLOWING INSTRUCTIONS CAREFULLY.

1. This paper consists of TWO sections: I and II.
2. Section I has EIGHT questions and Section II has THREE questions.
3. Answer ALL questions in Section I, and any TWO questions from Section II.
4. Write your answers in the booklet provided.
5. Do NOT write in the margins.
6. All working MUST be shown clearly.
7. A list of formulae is provided on page 4 of this booklet.
8. If you need to rewrite any answer and there is not enough space to do so on the original page, you must use the extra page(s) provided at the back of this booklet. Remember to draw a line through your original answer.
9. If you use the extra page(s) you MUST write the question number clearly in the box provided at the top of the extra page(s) and, where relevant, include the question part beside the answer.

Required Examination Materials:

Electronic calculator
Geometry set

DO NOT TURN THIS PAGE UNTIL YOU ARE TOLD TO DO SO.

Copyright © 2014 Caribbean Examinations Council
All rights reserved.

01234020/F 2016

“Barcode Area”
Sequential Bar Code

LIST OF FORMULAE

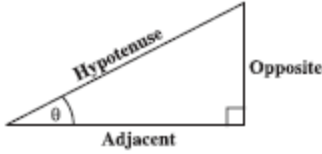
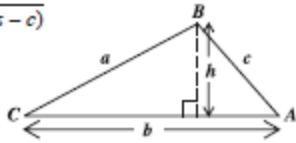
Volume of a prism	$V = Ah$ where A is the area of a cross-section and h is the perpendicular length.
Volume of cylinder	$V = \pi r^2 h$ where r is the radius of the base and h is the perpendicular height.
Volume of a right pyramid	$V = \frac{1}{3} Ah$ where A is the area of the base and h is the perpendicular height.
Circumference	$C = 2\pi r$ where r is the radius of the circle.
Arc length	$S = \frac{\theta}{360} \times 2\pi r$ where θ is the angle subtended by the arc, measured in degrees.
Area of a circle	$A = \pi r^2$ where r is the radius of the circle.
Area of a sector	$A = \frac{\theta}{360} \times \pi r^2$ where θ is the angle of the sector, measured in degrees.
Area of trapezium	$A = \frac{1}{2} (a + b) h$ where a and b are the lengths of the parallel sides and h is the perpendicular distance between the parallel sides.
Roots of quadratic equations	If $ax^2 + bx + c = 0$, then $x = \frac{-b \pm \sqrt{b^2 - 4ac}}{2a}$
Trigonometric ratios	$\sin \theta = \frac{\text{opposite side}}{\text{hypotenuse}}$ $\cos \theta = \frac{\text{adjacent side}}{\text{hypotenuse}}$ $\tan \theta = \frac{\text{opposite side}}{\text{adjacent side}}$
	
Area of triangle	Area of $\Delta = \frac{1}{2} bh$ where b is the length of the base and h is the perpendicular height. Area of $\Delta ABC = \frac{1}{2} ab \sin C$ Area of $\Delta ABC = \sqrt{s(s-a)(s-b)(s-c)}$ where $s = \frac{a+b+c}{2}$
Sine rule	$\frac{a}{\sin A} = \frac{b}{\sin B} = \frac{c}{\sin C}$ 
Cosine rule	$a^2 = b^2 + c^2 - 2bc \cos A$

GO ON TO THE NEXT PAGE

SECTION I

Answer ALL questions in this section.

All working must be clearly shown.

1. (a) Using a calculator, or otherwise, calculate

(i) $\frac{3\frac{3}{8} - 2\frac{1}{4}}{1\frac{1}{2}}$ giving your answer as a fraction in its lowest terms.

(2 marks)

(ii) $(2.86 + 0.75) + 0.481^2$ giving your answer correct to 2 decimal places.

(2 marks)

GO ON TO THE NEXT PAGE

01234020/F 2016

Barcode Area
Sequential Bar Code

- (b) Paul bought and sold a computer. He wrote his business activity as follows:

Cost price of computer = \$1064

Marked price of computer = \$1399

Discount on marked price = 5%
(if paid by cash)

Calculate

- (i) the selling price (paid cash)

(2 marks)

- (ii) the profit or loss as a percentage of the cost price.

(2 marks)

- (c) Orange juice is sold in cartons of three different sizes.

Carton Size	Selling Price
350 ml	\$4.20
450 ml	\$5.35
500 ml	\$5.80

Which size of orange juice is the most cost-effective buy? Justify your answer.

(3 marks)

Total 11 marks

2. (a) Factorize completely:

(i) $4a^2 - 16$

(2 marks)

(ii) $3y^2 + 2y - 8$

(2 marks)

(b) Solve the simultaneous equations:

$$2x + y = 3$$

$$5x - 2y = 12$$

(5 marks)

GO ON TO THE NEXT PAGE

- (c) The table below shows corresponding values of the variables x and y , where y varies directly as x .

x	6	10	t
y	3	u	9

Calculate the values of t and u .

(3 marks)

Total 12 marks

3. (a) The Venn diagram below shows the number of students who study History and French in a class of 30 students.

$U = \{\text{students in the class}\}$
 $H = \{\text{students who study History}\}$
 $F = \{\text{students who study French}\}$

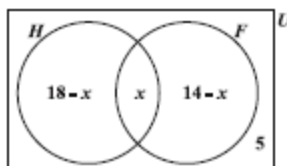

- (i) Write an expression, in x , in its simplest form, for the TOTAL number of students in the class.

..... (2 marks)

- (ii) State whether the following relationships are true or false:

• $H \cup F = U$

• $H \cap F' = \emptyset$

(2 marks)

- (iii) Determine the number of students who study BOTH History and French.

(2 marks)

- (b) (i) Using a ruler, a pencil and a pair of compasses, construct triangle PQR with $PQ = 5$ cm, $\angle PQR = 60^\circ$ and $\angle QPR = 90^\circ$.

(4 marks)

- (ii) Measure and state

- the length of PR

$PR =$

- the measure of $\angle PRQ$.

$\angle PRQ =$

(2 marks)

Total 12 marks

GO ON TO THE NEXT PAGE

4. The diagram below, not drawn to scale, shows a silver box with no lid. The sides and bottom of the box are 1.5 cm thick.

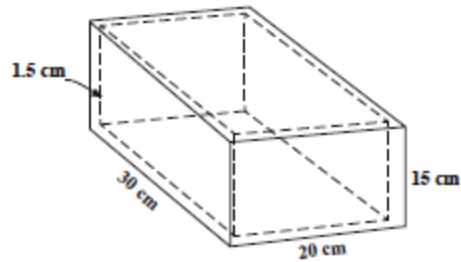

- (a) Calculate the volume of the box using the external measurements.

(2 marks)

- (b) Complete EACH of the following statements.

- (i) The internal length of the box is $30 \text{ cm} - 2 \times 1.5 \text{ cm} = \dots\dots\dots$ (1 mark)
- (ii) The internal width of the box is $\dots\dots\dots$ (2 marks)
- (iii) The internal depth of the box is $\dots\dots\dots$ (1 mark)

4. The diagram below, not drawn to scale, shows a silver box with no lid. The sides and bottom of the box are 1.5 cm thick.

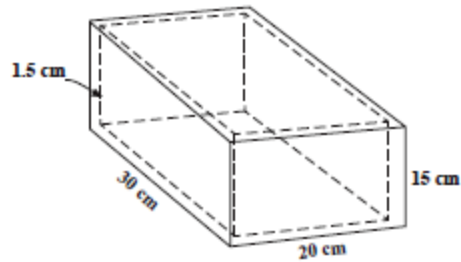

- (a) Calculate the volume of the box using the external measurements.

(2 marks)

- (b) Complete EACH of the following statements.

- (i) The internal length of the box is $30 \text{ cm} - 2 \times 1.5 \text{ cm} = \dots\dots\dots$ (1 mark)
- (ii) The internal width of the box is $\dots\dots\dots$ (2 marks)
- (iii) The internal depth of the box is $\dots\dots\dots$ (1 mark)

- (c) Calculate the internal volume of the box.

(2 marks)

- (d) The box is made of silver which has a mass of 10.5 g for each cm^3 . Calculate the mass of the silver box, giving your answer in kg.

(3 marks)

Total 11 marks

5. (a) The diagram below, not drawn to scale, shows two straight lines, JK and KL , intersecting a pair of parallel lines, EF and GH .

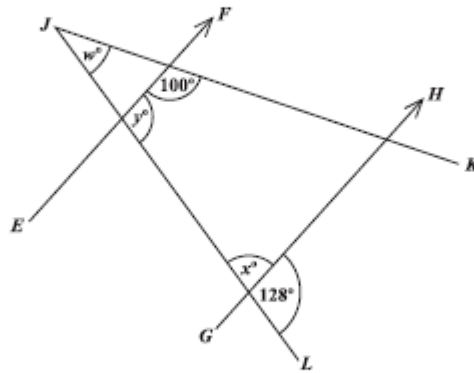

Determine, giving reasons for EACH of your answers, the value of

- (i) x

.....
(2 marks)

- (ii) y

.....
(2 marks)

- (iii) w .

.....
(2 marks)

- (b) The diagram below shows triangle RST and its image $R'S'T'$ after a transformation.

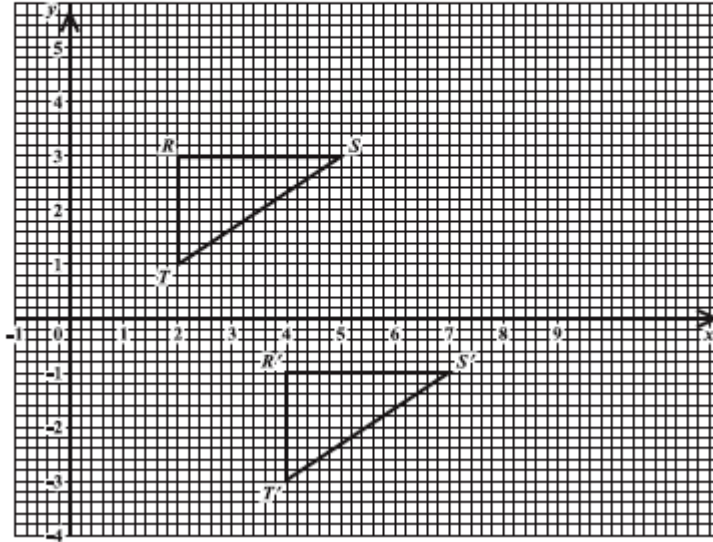

- (i) Describe FULLY the transformation which maps RST onto $R'S'T'$.

.....

(3 marks)

- (ii) Triangle RST is reflected in the line $x = 6$. On the graph above, draw triangle $R''S''T''$, the image of ΔRST , after the reflection.

Write down the coordinates of R'' .

$R'' =$

(3 marks)

Total 12 marks

6. (a) The diagram below shows the graph of the straight line $x + y = 3$.

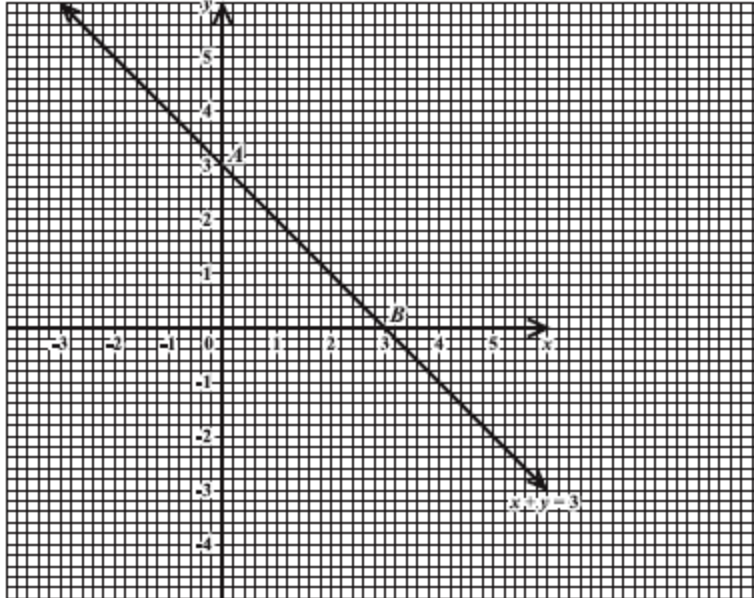

Determine the equation of the line which is

- (i) parallel to the line $x + y = 3$ and passes through the origin

(2 marks)

- (ii) perpendicular to the line $x + y = 3$ and passes through the midpoint of AB.

(2 marks)

- (b) The function $y = x^2 - 2x - 3$ is defined in the domain $-2 \leq x \leq 4$. The table below shows the corresponding values of y for five selected values of x .

x	-2	-1	0	1	2	3	4
y	5	0	-3		-3		5

- (i) Complete the table by calculating and inserting the missing values of y .

(2 marks)

- (ii) On the same axes used in Part (a) on page 16, draw the graph of $y = x^2 - 2x - 3$.
(2 marks)

- (iii) Using information from your graph, complete EACH of the following statements.

- The minimum value of $y = x^2 - 2x - 3$ occurs when $x = \dots\dots\dots$
(1 mark)

- The values of x for which $x^2 - 2x - 3 = -x + 3$ are $x = \dots\dots\dots$
and $x = \dots\dots\dots$ (2 marks)

Total 11 marks

7. Twenty bags of sugar were weighed. The weights, to the nearest kg, are as follows:

3	38	17	33	28
12	43	38	31	30
11	8	23	18	26
50	22	35	39	5

- (a) Complete the frequency table for the data shown above.

Weight (kg)	Tally	Number of Bags
1–10		
11–20		
21–30		
31–40		
41–50		

(4 marks)

- (b) For the class interval 21–30, state:

(i) the upper class boundary

.....
(1 mark)

(ii) the class width

.....
(1 mark)

(iii) the class midpoint

.....
(1 mark)

- (c) On the grid on page 19, using a scale of 2 cm to represent 10 kg on the x-axis, and 1 cm to represent 1 bag on the y-axis, draw a histogram to represent the data contained in your frequency table above.
(4 marks)

Total marks

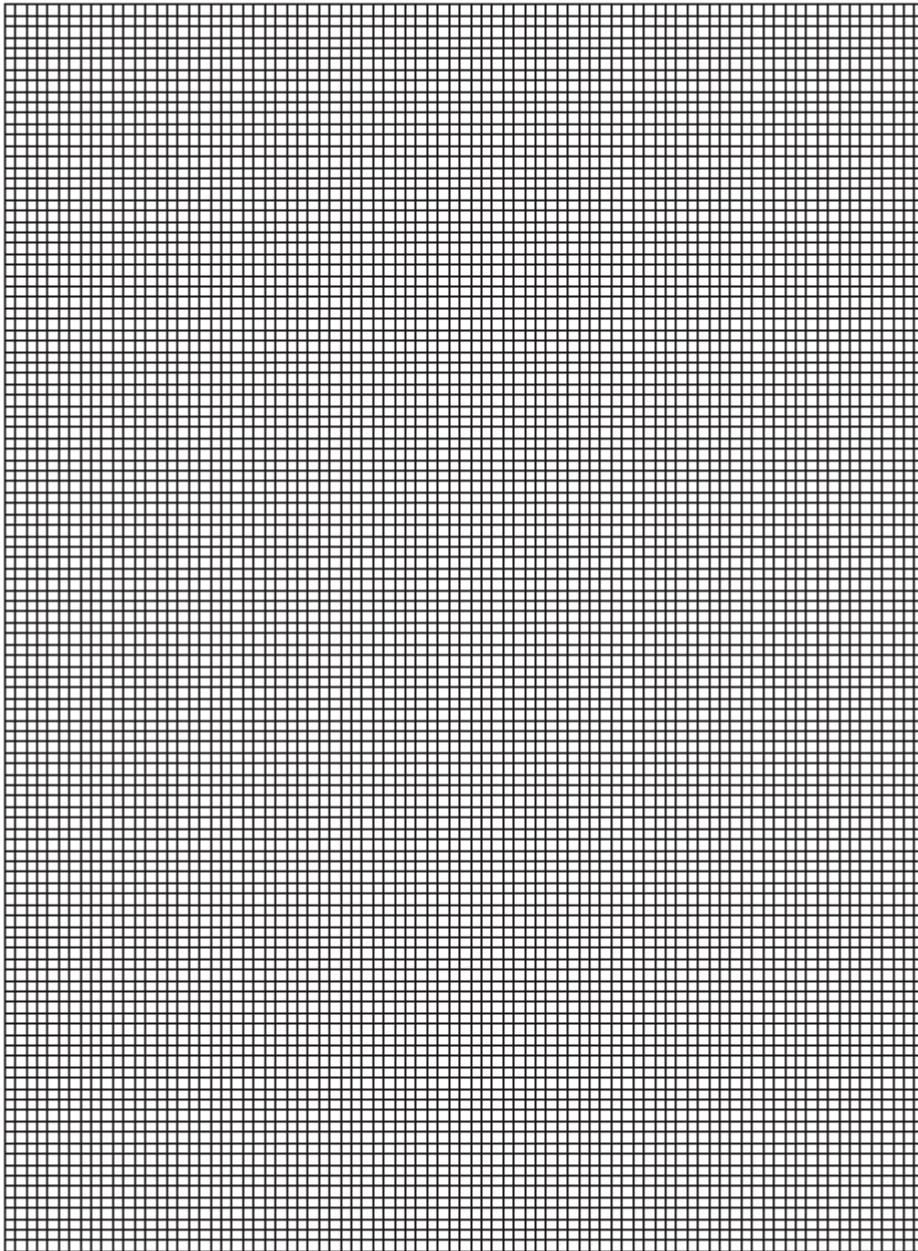

GO ON TO THE NEXT PAGE

01234020/F 2016

Barcode Area
Sequential Bar Code

8. The diagram below shows the first three figures in a sequence. Each figure is made up of knots and strings. Each knot connects exactly 3 strings.

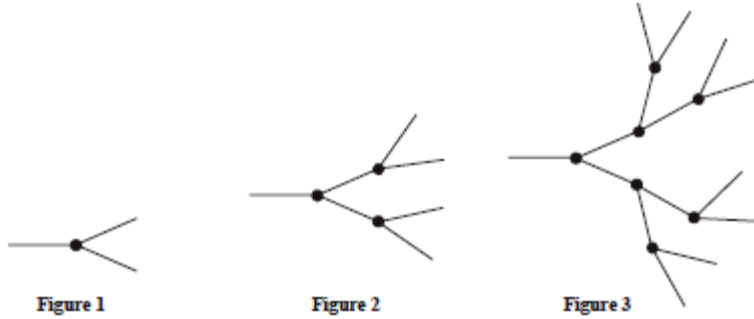

- (a) Draw Figure 4 of the sequence.

(2 marks)

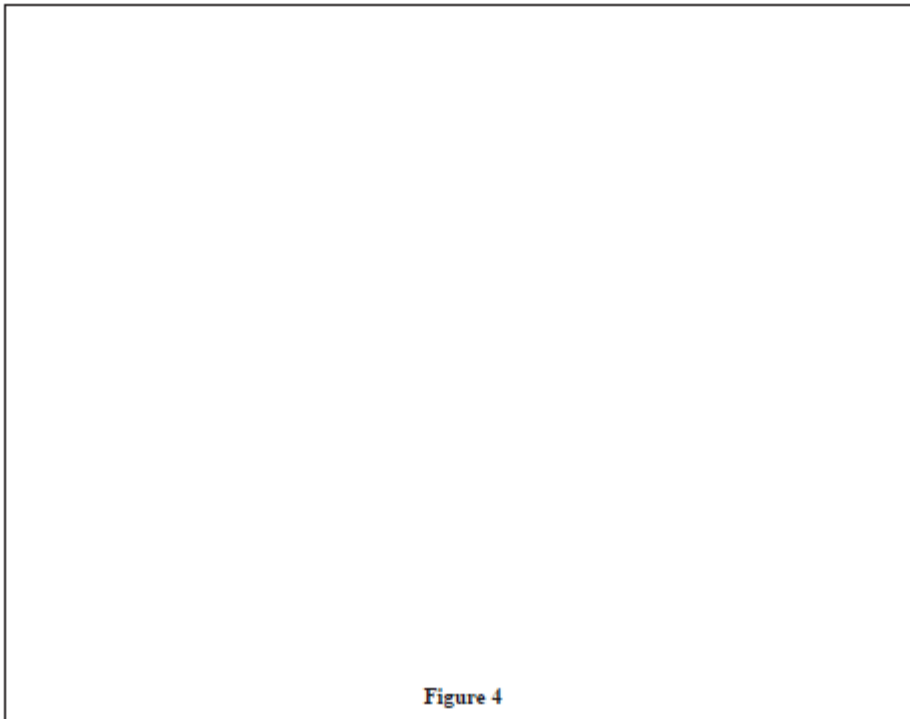

- (b) The table below shows the number of knots and strings in each figure used to draw Figures 1, 2 and 3. Complete the table by inserting the missing values in the rows numbered (i), (ii) and (iii).

Figure Number (N)	Number of Knots (K)	Number of Strings (S)	
1	1	3	
2	3	7	
3	7	15	
(i)	4	(2 marks)
(ii)	255	(3 marks)
(iii)	10	(3 marks)

Total 10 marks

SECTION II

Answer TWO questions in this section.

ALGEBRA AND RELATIONS, FUNCTIONS AND GRAPHS

9. (a) The functions $f(x)$ and $g(x)$ are defined as $f(x) = 2x - 7$ and $g(x) = x^2 + 1$, respectively.(i) Write an expression, in terms of x , for EACH of the following:

- $f^{-1}(x)$

- $g^{-1}(x)$

- $fg(x)$

• $(fg)^{-1}x$

(4 marks)

(ii) Show that $(fg)^{-1}(5) = g^{-1}f^{-1}(5)$.

(3 marks)

- (b) The distance–time graph below shows the three-stage journey of a car travelling from Town A to Town C and back to Town A.

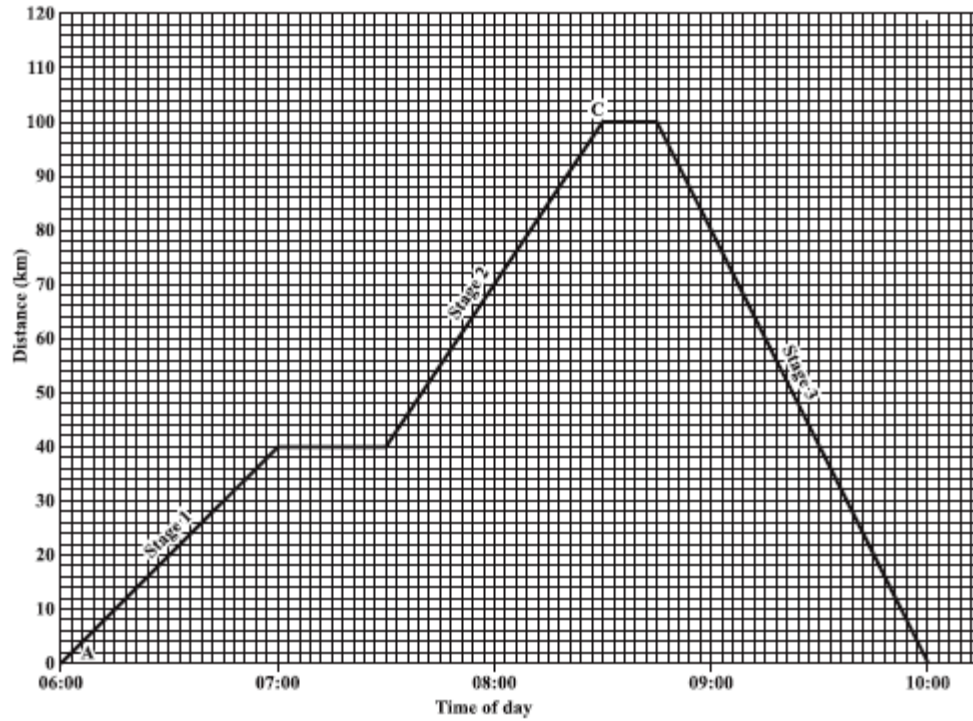

01234020/F 2016

GO ON TO THE NEXT PAGE

Barcode Area
Sequential Bar Code

- (i) State the time of day at which the car arrived at Town C.

.....
(1 mark)

- (ii) Calculate the TOTAL time, in minutes, for which the car stopped during the journey.

(2 marks)

- (iii) Determine the constant speed of the car during Stage 2 of the journey.

(2 marks)

- (iv) Calculate the average speed of the car for the time during which it was moving.

(3 marks)

Total 15 marks

GO ON TO THE NEXT PAGE

MEASUREMENT, GEOMETRY AND TRIGONOMETRY

10. (a) The diagram below, not drawn to scale, shows a circle, centre O . EH and EF are tangents to the circle. FOG and JOH are straight lines. The measure of $\angle FEH = 44^\circ$.

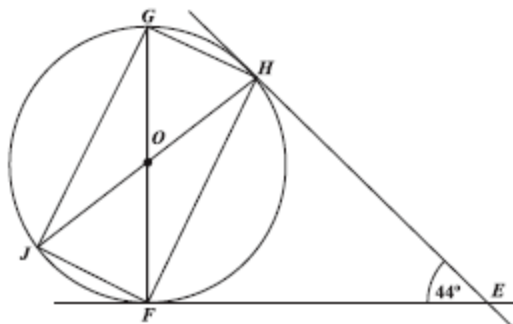

Calculate, giving reasons for your answer, the measure of:

(i) $\angle EHF = \dots\dots\dots$

(2 marks)

(ii) $\angle FGH = \dots\dots\dots$

(2 marks)

(iii) $\angle JHE = \dots\dots\dots$

(2 marks)

(iv) $\angle JGH = \dots\dots\dots$

(2 marks)

- (b) The diagram below, not drawn to scale, shows two ships, R and S at anchor on a lake of calm water. FT is a vertical tower. FSR is a straight line and $RS = 150$ m. The angles of elevation of T , the top of a tower, from R and S , are 22° and 40° respectively. F is the foot of the tower.



Calculate, giving your answer to 1 decimal place where appropriate

- (i) the measure of $\angle RTS$

(1 mark)

- (ii) the length of ST

(3 marks)

- (iii) the height of the tower, FT .

(3 marks)

Total 15 marks

GO ON TO THE NEXT PAGE

VECTORS AND MATRICES

11. (a) The position vectors of points A , B and C , relative to the origin O , are

$$\vec{OA} = \begin{pmatrix} 2 \\ -2 \end{pmatrix}; \vec{OB} = \begin{pmatrix} 6 \\ 1 \end{pmatrix} \text{ and } \vec{OC} = \begin{pmatrix} 10 \\ 4 \end{pmatrix} \text{ respectively.}$$

- (i) Express in the form $\begin{pmatrix} x \\ y \end{pmatrix}$ the vectors

• $\vec{AB} = \dots\dots\dots$

• $\vec{AC} = \dots\dots\dots$

(3 marks)

- (ii) Hence, determine whether A , B and C are collinear, giving the reasons for your answer.

.....

.....

.....

(3 marks)

GO ON TO THE NEXT PAGE

- (b) Determine the value of x for which the matrix $\begin{pmatrix} 3 & x \\ 2 & 4 \end{pmatrix}$ is singular.

(2 marks)

- (c) N and P are 2×2 matrices such that $N = \begin{pmatrix} 4 & 1 \\ 3 & 2 \end{pmatrix}$ and $P = \begin{pmatrix} 1 & 5 \\ 2 & 1 \end{pmatrix}$.

- (i) Determine NP .

(1 mark)

- (ii) Given that $PN = \begin{pmatrix} 19 & 11 \\ 11 & 4 \end{pmatrix}$, determine whether matrix multiplication is commutative.

(1 mark)

GO ON TO THE NEXT PAGE

(iii) Determine N^{-1} , the inverse of N .

(2 marks)

(iv) Hence, calculate the values of x and y for which $\begin{pmatrix} 4 & 1 \\ 3 & 2 \end{pmatrix} \begin{pmatrix} x \\ y \end{pmatrix} = \begin{pmatrix} 1 \\ 2 \end{pmatrix}$.

(3 marks)

Total 15 marks

END OF TEST

IF YOU FINISH BEFORE TIME IS CALLED, CHECK YOUR WORK ON THIS TEST.

01234020/F 2016

Barcode Area
Sequential Bar Code