



CARIBBEAN EXAMINATIONS COUNCIL
CARIBBEAN SECONDARY EDUCATION CERTIFICATE®
EXAMINATION

MATHEMATICS

Paper 02 – General Proficiency

2 hours 40 minutes

READ THE FOLLOWING INSTRUCTIONS CAREFULLY.

1. This paper consists of TWO sections: I and II.
2. Section I has SEVEN questions and Section II has THREE questions.
3. Answer ALL questions.
4. Write your answers in the spaces provided in this booklet.
5. Do NOT write in the margins.
6. All working MUST be clearly shown.
7. A list of formulae is provided on page 4 of this booklet.
8. If you need to rewrite any answer and there is not enough space to do so on the original page, you must use the extra page(s) provided at the back of this booklet. Remember to draw a line through your original answer.
9. If you use the extra page(s), you MUST write the question number clearly in the box provided at the top of the extra page(s) and, where relevant, include the question part beside the answer.
10. ALL diagrams in this booklet are NOT drawn to scale, unless otherwise stated.

Required Examination Materials

Electronic calculator
Geometry set

DO NOT TURN THIS PAGE UNTIL YOU ARE TOLD TO DO SO.

Copyright © 2022 Caribbean Examinations Council
All rights reserved.



LIST OF FORMULAE

Volume of a prism	$V = Ah$ where A is the area of a cross-section and h is the perpendicular length.
Volume of a cylinder	$V = \pi r^2 h$ where r is the radius of the base and h is the perpendicular height.
Volume of a right pyramid	$V = \frac{1}{3} Ah$ where A is the area of the base and h is the perpendicular height.
Circumference	$C = 2\pi r$ where r is the radius of the circle.

Arc length $S = \frac{\theta}{360} \times 2\pi r$ where θ is the angle subtended by the arc, measured in degrees.

Area of a circle $A = \pi r^2$ where r is the radius of the circle.

Area of a sector $A = \frac{\theta}{360} \times \pi r^2$ where θ is the angle of the sector, measured in degrees.

Area of a trapezium $A = \frac{1}{2} (a + b) h$ where a and b are the lengths of the parallel sides and h is the perpendicular distance between the parallel sides.

Roots of quadratic equations If $ax^2 + bx + c = 0$,

$$\text{then } x = \frac{-b \pm \sqrt{b^2 - 4ac}}{2a}$$

Trigonometric ratios

$$\sin \theta = \frac{\text{length of opposite side}}{\text{length of hypotenuse}}$$

$$\cos \theta = \frac{\text{length of adjacent side}}{\text{length of hypotenuse}}$$

$$\tan \theta = \frac{\text{length of opposite side}}{\text{length of adjacent side}}$$

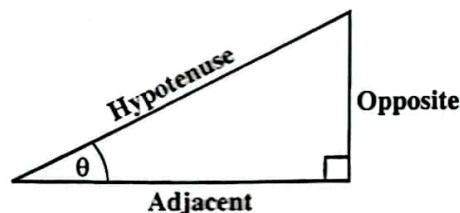

Area of a triangle

Area of $\Delta = \frac{1}{2} bh$ where b is the length of the base and h is the perpendicular height.

$$\text{Area of } \Delta ABC = \frac{1}{2} ab \sin C$$

$$\text{Area of } \Delta ABC = \sqrt{s(s-a)(s-b)(s-c)}$$

$$\text{where } s = \frac{a+b+c}{2}$$

$$\frac{a}{\sin A} = \frac{b}{\sin B} = \frac{c}{\sin C}$$

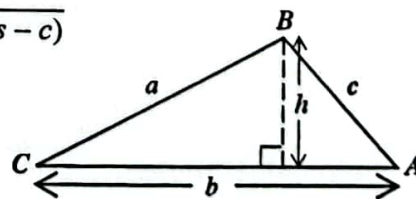

Sine rule

Cosine rule

$$a^2 = b^2 + c^2 - 2bc \cos A$$

GO ON TO THE NEXT PAGE

01234020/MJ/CSEC 2023



0 1 2 3 4 0 2 0 0 4

SECTION I

Answer ALL questions.

All working MUST be clearly shown.

1. (a) Find the EXACT value of

$$\frac{5}{6} + \frac{2}{3} - \frac{12}{35} \times \frac{7}{9}.$$

.....
(2 marks)

- (b) (i) Calculate the value of $\sqrt{1 - (\cos 37^\circ)^2}$ correct to 3 decimal places.

.....
(2 marks)



- (ii) Write 0.00527 in standard form.

.....
(1 mark)

- (c) Haresh works at a call centre for 35 hours each week. He is paid an hourly rate of \$11.20.

- (i) Calculate the amount of money Haresh earns in a **four-week month**.

.....
(2 marks)

- (ii) In a certain week, Haresh works 8 hours overtime. Overtime hours are paid at $1\frac{1}{2}$ times the usual rate of \$11.20 per hour.

Find the **TOTAL** amount of money Haresh is paid for **that week**.

.....
(2 marks)

Total 9 marks



2. (a) Simplify $\frac{4}{5x} \times \frac{15x}{16}$.

.....
(1 mark)

(b) Solve the inequality $12 - 4m \leq 5 - 8m$.

.....
(2 marks)



- (c) The diagram below shows a compound shape, $LMNPQR$, made from two rectangles. The lengths in the diagram, which are written in terms of x , are in centimetres.

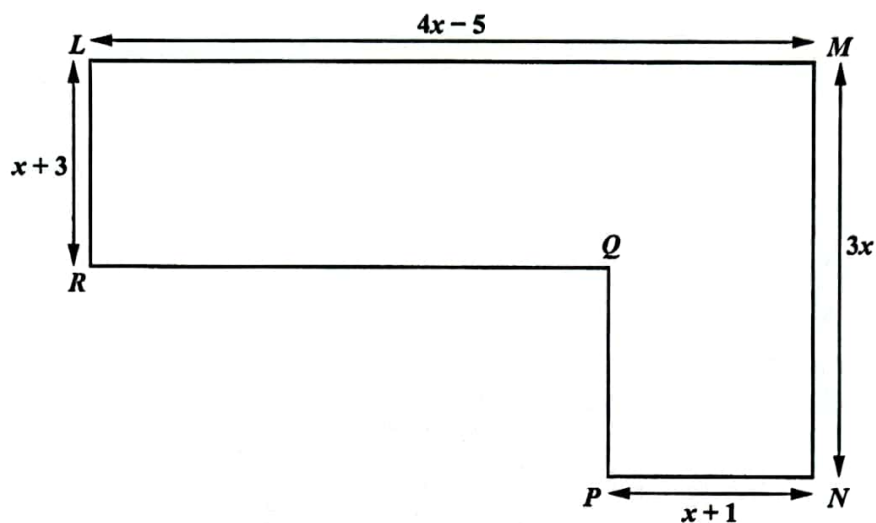

- (i) Find an expression, in terms of x , for the length

a) PQ

.....
(1 mark)

b) RQ .

.....
(1 mark)



- (ii) Given that the TOTAL area of the shape is 414 cm^2 , show that $x^2 + x - 72 = 0$.

.....
(4 marks)

Total 9 marks



3. (a) The diagram below shows a semicircle with diameter AC . B is a point on the circumference and $AB = BC = 8.2$ cm.

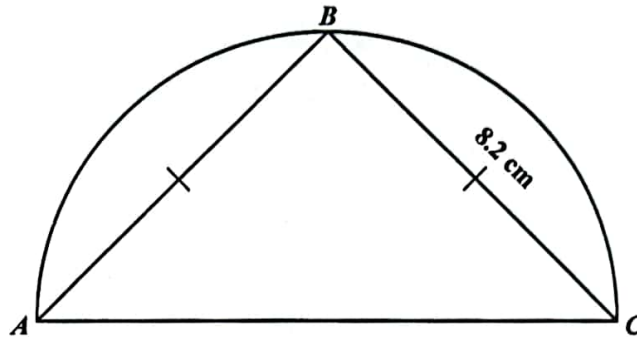

- (i) State the geometrical name of the line AB .

.....
(1 mark)

- (ii) Find the value of the radius of the circle.

.....
(3 marks)



- (b) Each interior angle of a regular polygon is 160° . Calculate the number of sides of the polygon.

.....
(2 marks)



- (c) The diagram below shows a trapezium, A , drawn on a square grid.

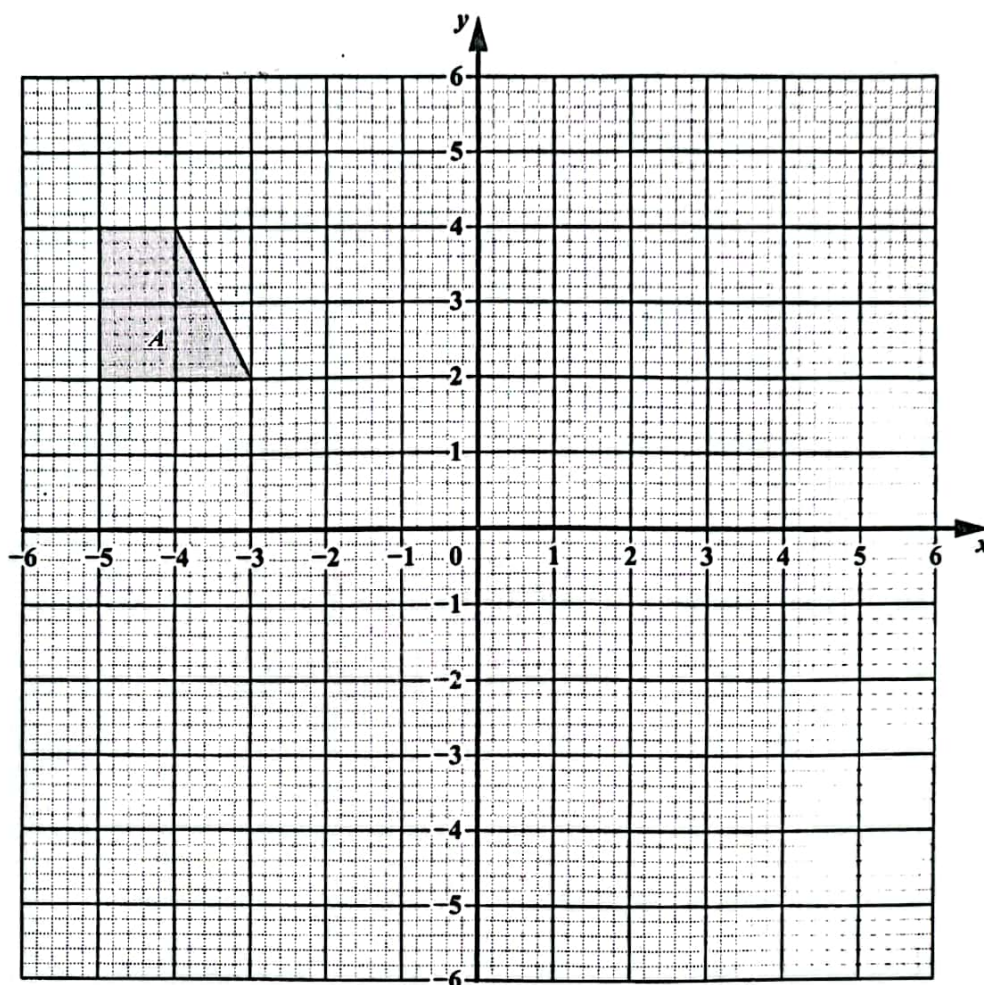

On the diagram above, draw the image of A after it undergoes a

- (i) reflection in the line $x = -1$ and label this image A' . (2 marks)
- (ii) translation with vector $\begin{pmatrix} 4 \\ -7 \end{pmatrix}$ and label this image A'' . (1 mark)

Total 9 marks



4. Consider the following functions.

$$f(x) = \frac{3}{x+2}, g(x) = 4x - 5 \text{ and } h(x) = x^2 + 1.$$

- (a) (i) For what value of x is $f(x)$ undefined?

.....
(1 mark)

- (ii) Find the value of

a) $g\left(\frac{1}{4}\right)$

.....
(1 mark)

b) $h(-3)$

.....
(1 mark)

c) $ff(0)$.

.....
(2 marks)



DO NOT WRITE IN THIS AREA

(b) Write an expression, in its **simplest form**, for $gh(x)$.

(2 marks)

(c) Find $g^{-1}(-2)$.

(2 marks)

Total 9 marks

GO ON TO THE NEXT PAGE



5. Each of 75 girls recorded the name of her favourite sport. The number of girls who chose track and cricket are shown on the bar chart below.

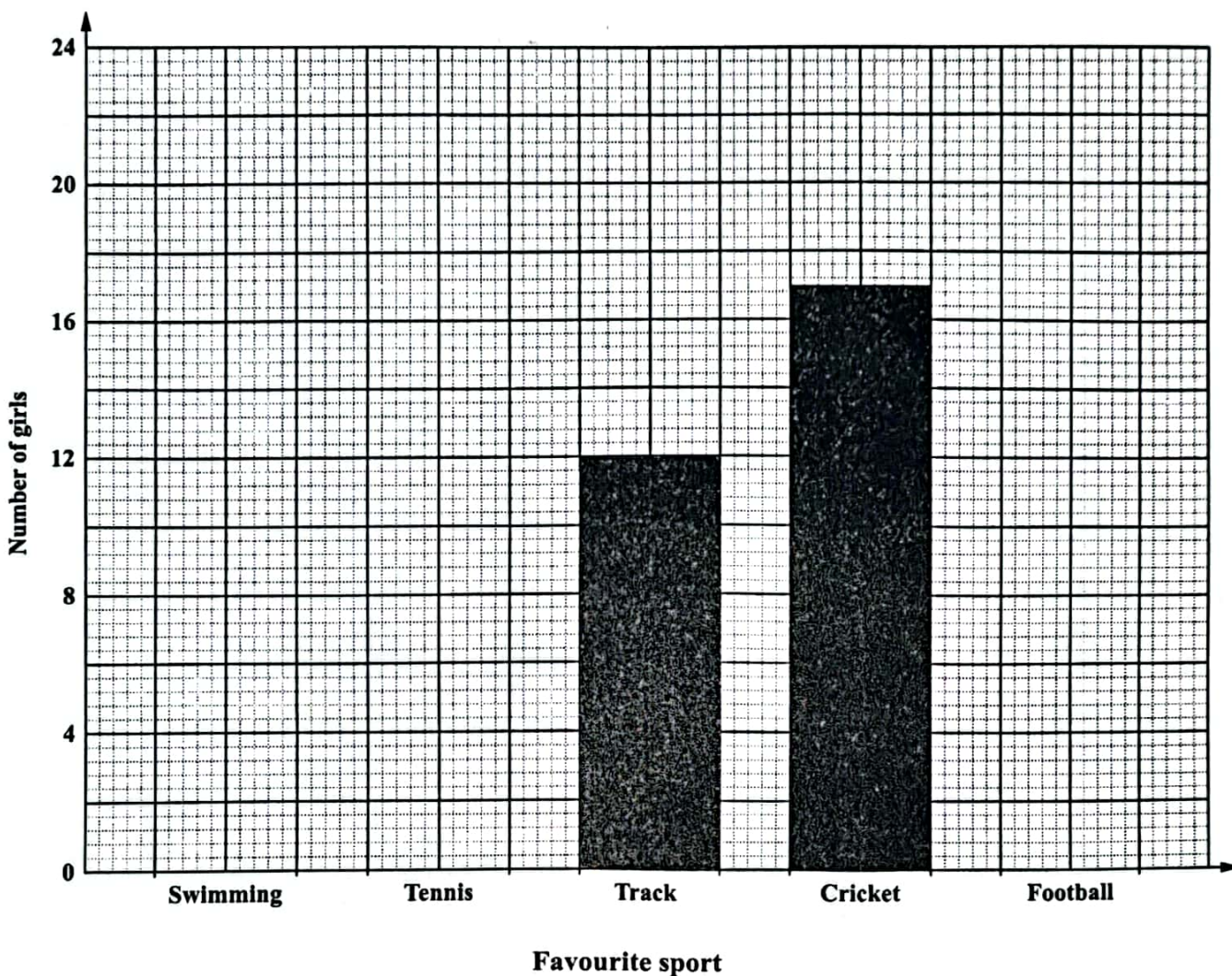

- (a) How many more girls chose cricket than track as their favourite sport?

 (1 mark)
- (b) Eleven girls recorded tennis as their favourite sport. For the remaining girls, the number who chose swimming compared to the number who chose football was in the ratio 2:3.
 Use this information to complete the bar chart above. (3 marks)
- (c) Determine the modal sport.

 (1 mark)

GO ON TO THE NEXT PAGE



- (d) One of the girls is selected at random. What is the probability that she chose NEITHER track NOR cricket as her favourite sport?

.....
(2 marks)

- (e) The information on the favourite sport of the 75 girls is to be shown on a pie chart. Calculate the sector angle for football.

.....
(2 marks)

Total 9 marks

GO ON TO THE NEXT PAGE



6. [In this question, take $\pi = \frac{22}{7}$ and the volume, V , of a cone with radius r and height h as

$$V = \frac{1}{3} \pi r^2 h.]$$

The diagram below shows a sector $OMRN$, of a circle with centre O , radius 12 cm and sector angle 168° , which was formed using a thin sheet of metal.

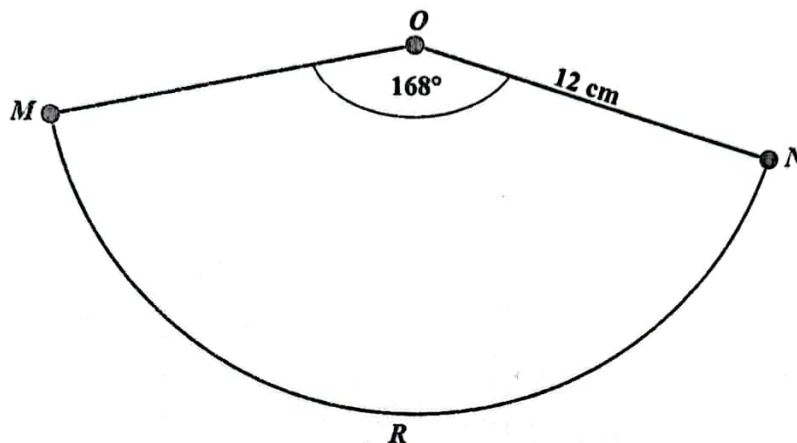

- (a) Calculate the perimeter of the sector above, made from the thin sheet of metal.

.....
(3 marks)



- (b) A cone is made from the sector in (a) by joining OM to ON , as shown below.

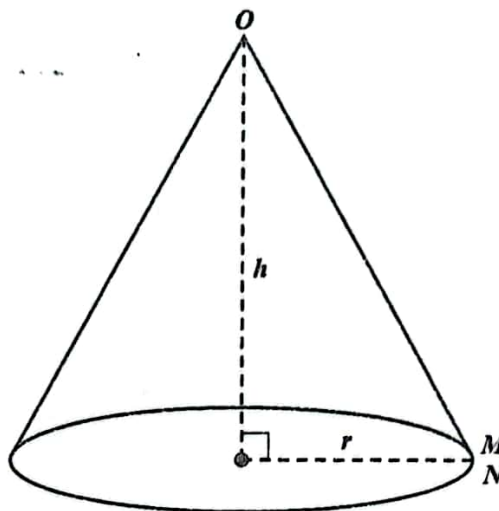

- (i) Calculate the
- a) radius, r , of the cone

.....
(2 marks)

- b) height, h , of the cone.

.....
(2 marks)



(ii) Calculate the capacity of the cone, in litres.

.....
(2 marks)

Total 9 marks

GO ON TO THE NEXT PAGE



7. A sequence of designs is made using black discs and white discs. The first 3 designs in the sequence are shown below.

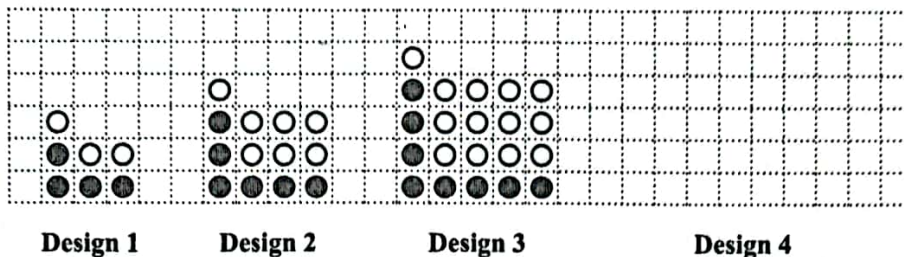

- (a) In the space provided on the grid above, draw Design 4. (2 marks)
- (b) The number of white discs, W , the number of black discs, B , and the total number of discs, T , that form each design follow a pattern. The values for W , B and T for the first 3 designs are shown in the table below. Study the pattern of numbers in the table.

Complete Rows (i), (ii) and (iii) in the table below.

Design Number (P)	Number of White Discs (W)	Number of Black Discs (B)	Total Number of Discs (T)	
1	$(1 \times 1) + 1 + 1 = 3$	4	7	
2	$(2 \times 2) + 2 + 1 = 7$	6	13	
3	$(3 \times 3) + 3 + 1 = 13$	8	21	
\vdots	\vdots	\vdots	\vdots	
(i) 9	$(\dots \times \dots) + \dots + \dots = \dots$	111	(2 marks)
\vdots	\vdots	\vdots	\vdots	
(ii)	$(20 \times 20) + 20 + 1 = 421$	(2 marks)
\vdots	\vdots	\vdots	\vdots	
(iii) n	(3 marks)



(c) Stephen has 28 black discs and 154 white discs, and wants to make Design 12. Explain why it is NOT possible for him to make Design 12.

.....

.....

.....

.....

.....

(1 mark)

Total 10 marks



SECTION II

Answer ALL questions.

ALL working MUST be clearly shown.

ALGEBRA, RELATIONS, FUNCTIONS AND GRAPHS

8. (a) Complete the table for the function
- $y = -x^2 + x + 7$
- .

x	-3	-2	-1	0	1	2	3	4
y		1		7		5		-5

(2 marks)



(b) On the grid below, draw the graph of $y = -x^2 + x + 7$ for $-3 \leq x \leq 4$.

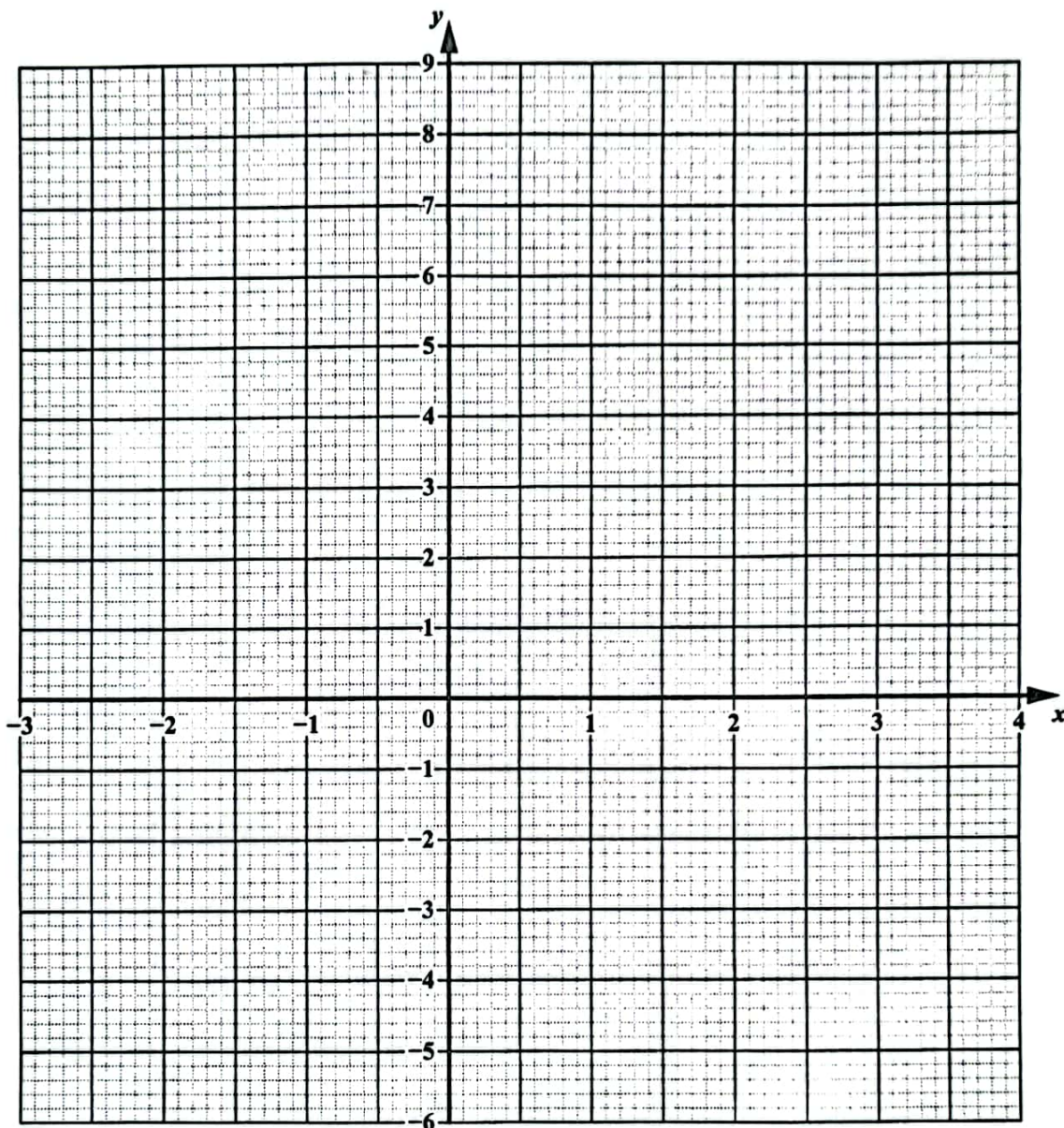

(3 marks)

(c) Write down the coordinates of the maximum/minimum point of the graph.

(..... ,)

(1 mark)



(d) Write down the equation of the axis of symmetry of the graph.

.....
(1 mark)

(e) Use your graph to find the solutions of the equation $-x^2 + x + 7 = 0$.

$x =$ or $x =$ (2 marks)

(f) (i) On the grid on page 24, draw a line through the points $(-3, -1)$ and $(0, 8)$. (1 mark)

(ii) Determine the equation of this line in the form $y = mx + c$.

.....
(2 marks)

Total 12 marks

DO NOT WRITE IN THIS AREA



GEOMETRY AND TRIGONOMETRY

9. (a) L, M, N and R are points on the circumference of a circle, with centre O . PQ is a tangent to the circle at R . Angle $PRL = 48^\circ$ and Angle $RON = 156^\circ$.

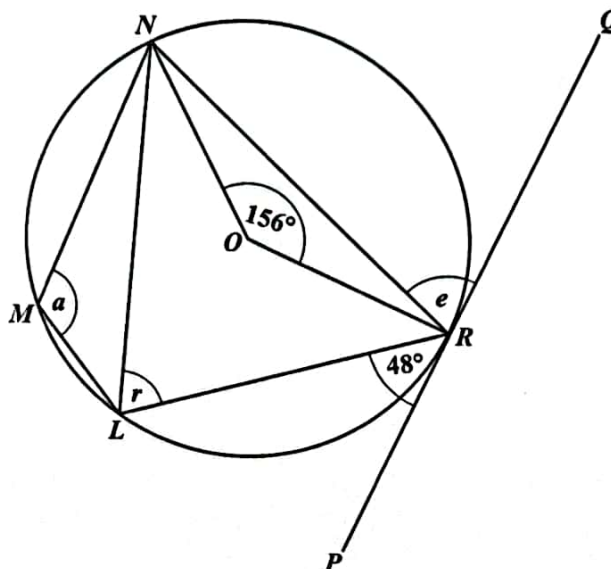

Find the value of EACH of the following angles, giving reasons for EACH of your answers. Show ALL working where appropriate.

- (i) Angle r

.....

.....

.....

.....

(2 marks)



(ii) Angle e

.....

.....

.....

.....

(2 marks)

(iii) Angle a

.....

.....

.....

.....

(2 marks)



DO NOT WRITE IN THIS AREA

- (b) The diagram below shows a triangular field, LMP , on horizontal ground.

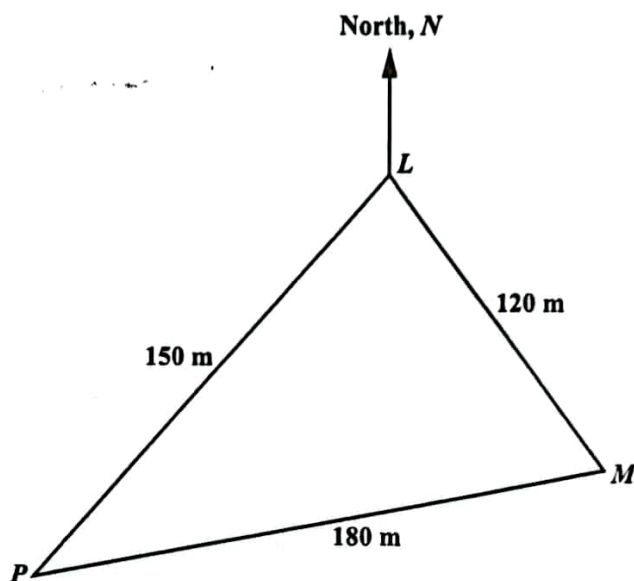

- (i) Calculate the value of Angle MLP .

(3 marks)



- (ii) The bearing of P from L is 210° .
- a) Find the bearing of M from L .

.....
(1 mark)

- b) Calculate the value of Angle NLP and hence, find the bearing of L from P .

.....
(2 marks)

Total 12 marks



VECTORS AND MATRICES

10. (a) The matrices A and B represent the transformations given below.

$A = \begin{pmatrix} 0 & -1 \\ 1 & 0 \end{pmatrix}$ represents an anticlockwise rotation of 90° about the origin, O .

$B = \begin{pmatrix} 0 & -1 \\ -1 & 0 \end{pmatrix}$ represents a reflection in the straight line $y = -x$.

- (i) Determine the elements of the matrix C which represents an anticlockwise rotation of 90° about the origin, O , followed by a reflection in the straight line $y = -x$.

.....
(2 marks)

- (ii) Describe, geometrically, the single transformation represented by C .

.....
.....
.....
(2 marks)



- (b) A transformation, T , is defined by the following 2×2 matrix.

$$T = \begin{pmatrix} 1 & 2 \\ k & -1 \end{pmatrix}, \text{ where } k \text{ is a constant.}$$

T maps the point $(2, 3)$ onto the point $(8, 15)$.

Determine the value of k .

(2 marks)



- (c) The following vectors are defined as shown below.

$$\overrightarrow{WX} = \begin{bmatrix} 5 \\ -1 \end{bmatrix} \quad \overrightarrow{XY} = \begin{bmatrix} -3 \\ 7 \end{bmatrix} \quad \overrightarrow{ZY} = \begin{bmatrix} 8 \\ -7 \end{bmatrix}$$

Determine EACH of the following.

- (i) A vector, other than $\begin{bmatrix} 5 \\ -1 \end{bmatrix}$, that is parallel to \overrightarrow{WX}

.....
(1 mark)

- (ii) \overrightarrow{WY}

.....
(1 mark)

- (iii) \overrightarrow{XZ}

.....
(2 marks)



(iv) $|\vec{XY}|$

.....
(2 marks)

Total 12 marks

END OF TEST

IF YOU FINISH BEFORE TIME IS CALLED, CHECK YOUR WORK ON THIS TEST.

01234020/MJ/CSEC 2023

